

# Introduction to Wireless Signal Propagation

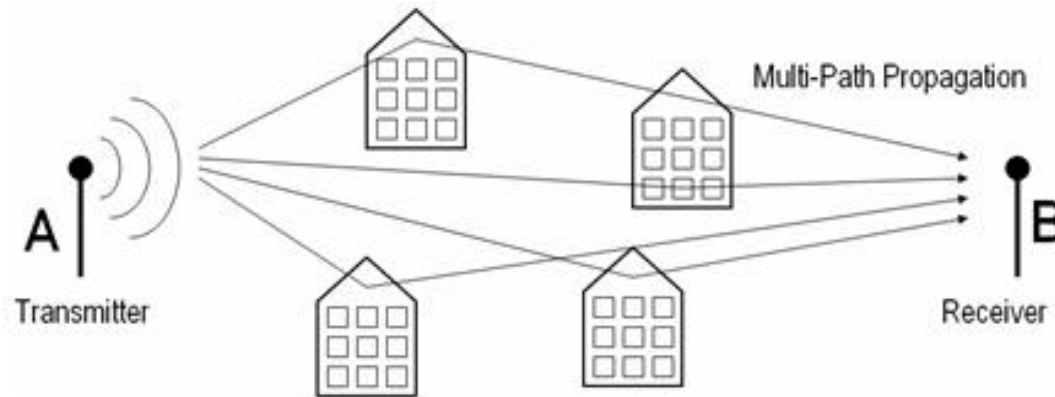

**Raj Jain**

Professor of Computer Science and Engineering  
Washington University in Saint Louis  
Saint Louis, MO 63130  
Jain@cse.wustl.edu

Audio/Video recordings of this class lecture are available at:

<http://www.cse.wustl.edu/~jain/cse574-24/>

**Student Questions**



1. Reflection, Diffraction, Scattering
2. Fading, Shadowing, multipath
3. Fresnel Zones
4. Multi-Antenna Systems, Beamforming, MIMO
5. OFDM

Note: This is the second in a series of lectures on the wireless physical layer. The other lecture discussed modulation, coding, Shannon's theorem, and other topics.

## Student Questions

# Wireless Radio Channel

- ❑ Path loss: Depends upon distance and frequency
- ❑ Noise
- ❑ Shadowing: Obstructions
- ❑ Frequency Dispersion (Doppler Spread) due to motion
- ❑ Interference
- ❑ Multipath: Multiple reflected waves
- ❑ Inter-symbol interference (ISI) due to dispersion

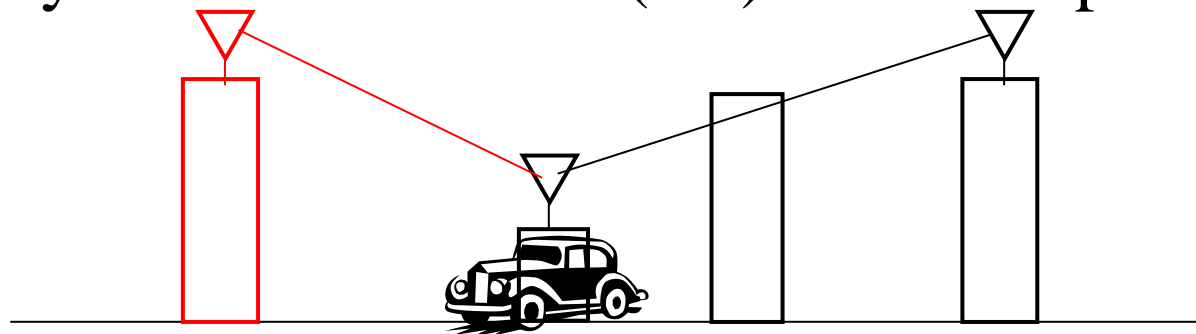

## Student Questions

- ❑ Could we go over how this figure relates to the terms above? *Shows different path loss in red and black paths*
- ❑ So, both Multipath and ISI interfere with the transmitted waves themselves, but multipath is due to the existence of reflector(s), and ISI is due to moving waves? *Multipath is due to the interference of waves. ISI can happen even in a single wave it travels too far. See Slide 4-10.*

# Wireless Radio Channel

- ❑ Path loss: Depends upon distance and frequency
- ❑ Noise
- ❑ Shadowing: Obstructions
- ❑ Frequency Dispersion (Doppler Spread) due to motion
- ❑ Interference
- ❑ Multipath: Multiple reflected waves
- ❑ Inter-symbol interference (ISI) due to dispersion

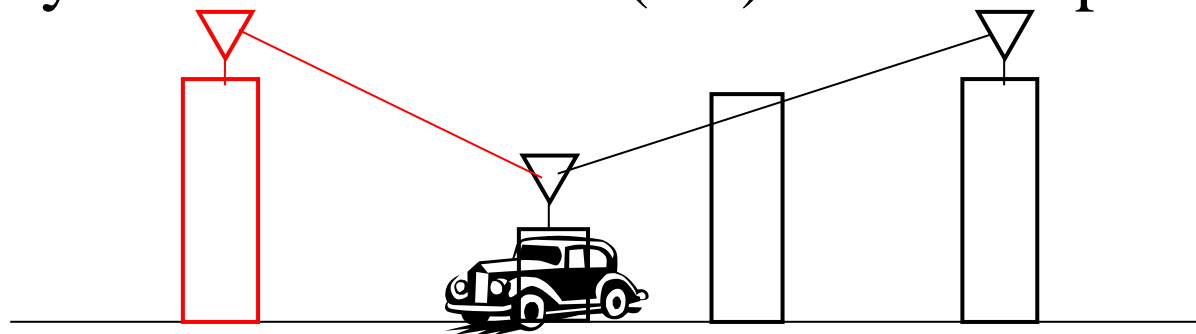

## Student Questions

- ❑ What does it mean that “you sent ONE micro-second out but got TEN micro-second back.”

*The symbol width changes as shown in Slide 4-10.*

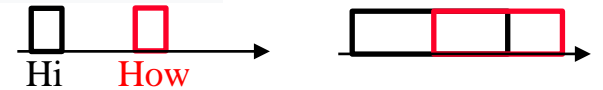

- ❑ Does the symbol width indicate that you are moving in the same direction as you sent the signal out?

*No movement affects the frequency more. Width is affected by the path length.*

# Antenna

- ❑ Transmitter converts electrical energy to electromagnetic waves
- ❑ Receiver converts electromagnetic waves to electrical energy
- ❑ The same antenna is used for transmission and reception
- ❑ Omni-Directional: Power radiated in all directions
- ❑ Directional: Most power in the desired direction
- ❑ Isotropic antenna: Radiates in all directions equally
- ❑ Antenna Gain = Power at a particular point/Power with Isotropic **is** expressed in dBi.

$$P_r = P_t G_t G_r (\lambda/4\pi d)^2$$

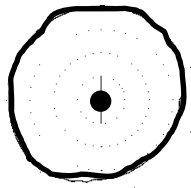

Omni-Directional

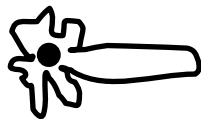

Directional

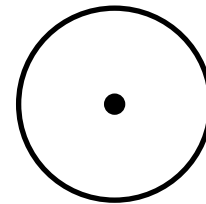

Isotropic

## Student Questions

- ❑ Can you explain the difference between Omni-Directional, Directional, and Isotropic? *Isotropic is the ideal omnidirectional antenna (used for reference).*
- ❑ Omni-directional is radiated in all directions, but not equally? *Almost equally, but not a perfect circle. Isotropic is theoretical, while omnidirectional, as shown, is what you get in practice.*
- ❑ What is the unit dBi, and how would you work with it in the equation given?

*dBi = Deci-Bel isotropic = Power compared to an isotropic antenna*

*The formula gives power in Watts.  $10\log_{10}P$  changes it to dB.*

- ❑ Isn't the difference between isotropic and Omni that iso transmits the power in a circle shape and Omni in a sphere shape?

*Isotropic = equal in 3D*

*Omni = Equal in 2D*

- ❑ I wonder why the azimuth pattern of Omni-directional (left figure) is not a circle.

*Isotropic is theoretical. Omni shown here is realistic.*

- ❑ Does the 'd' variable mean the distance between the antennas? And is there a reason we consider the area formula instead of the volume, as the transmissions will be spherical?

*The formula is for the power received at an antenna.*

# Antenna

- ❑ Transmitter converts electrical energy to electromagnetic waves
- ❑ Receiver converts electromagnetic waves to electrical energy
- ❑ The same antenna is used for transmission and reception
- ❑ Omni-Directional: Power radiated in all directions
- ❑ Directional: Most power in the desired direction
- ❑ Isotropic antenna: Radiates in all directions equally
- ❑ Antenna Gain = Power at a particular point/Power with Isotropic  
**is** expressed in dBi.

$$P_r = P_t G_t G_r (\lambda/4\pi d)^2$$

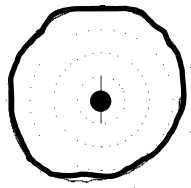

Omni-Directional

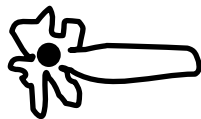

Directional

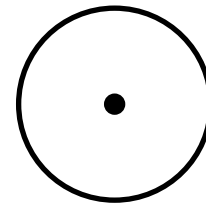

Isotropic

## Student Questions

- ❑ You drew omni-directional as a bumpy circle, so does that mean omni-directional is explicitly not isotropic?

*Not perfect isotropic.*

# Reflection, Diffraction, Scattering

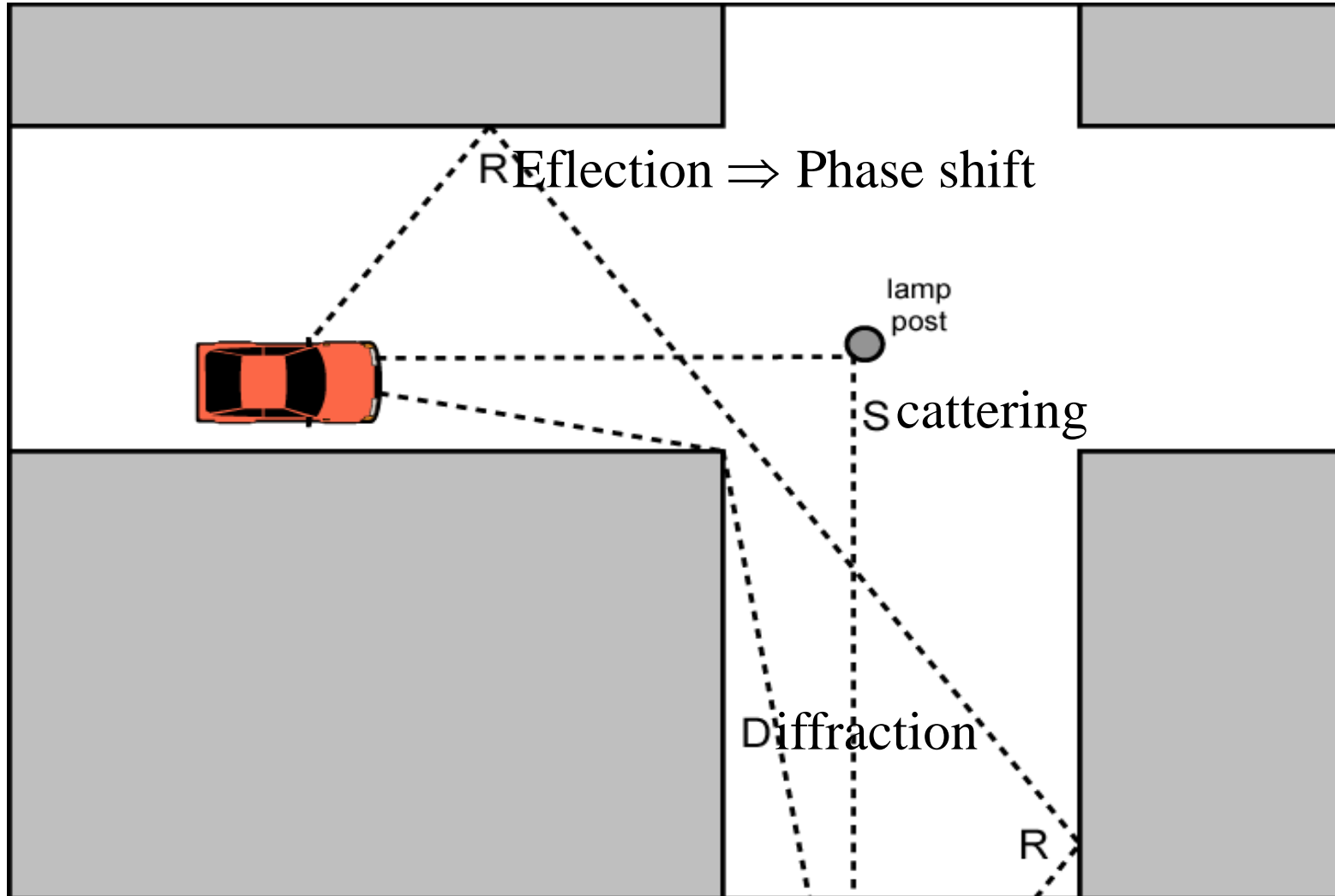

**Student Questions**

# Reflection, Diffraction and Scattering (Cont)

- ❑ **Reflection:** Surface large relative to the wavelength of the signal
  - May have a phase shift from the original
  - May cancel out original or increase it
- ❑ **Diffraction:** Edge of the impenetrable body that is large relative to  $\lambda$ 
  - May receive signal even if there is no line of sight (LOS) to the transmitter
- ❑ **Scattering**
  - Obstacle size on the order of wavelength. Lamp posts, etc.
- ❑ If LOS, diffracted and scattered signals are not significant
  - Reflected signals may be
- ❑ If no LOS, **reflection**, diffraction, and scattering are primary means of reception

## Student Questions

- ❑ Why is scattering a primary reception mean if there is no LOS?  
*Power received = LOS + Reflection, diffraction, and scattering*  
*If one or more are missing, others become the means for a reception.*
-



# Channel Model

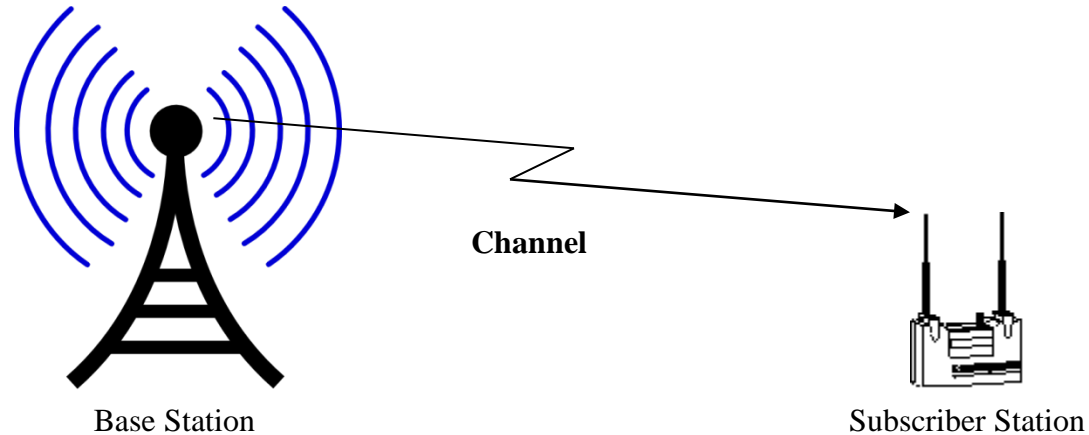

- ❑ The power profile of the received signal can be obtained by *convolving* the transmitted signal's power profile with the channel's impulse response.
- ❑ Convolution in time = multiplication in the frequency domain
- ❑ Signal  $x$ , after propagation through the channel  $H$  becomes  $y$ :
$$y(f) = H(f)x(f) + n(f)$$
- ❑ Here,  $H(f)$  is **channel response**, and  $n(f)$  is the noise. Note that  $x$ ,  $y$ ,  $H$ , and  $n$  are all functions of the signal frequency  $f$ .

## Student Questions

- ❑ What is the power profile of the transmitted signal?

*Power profile = power as a function of frequency*

---

# Path Loss

- ❑ Power is distributed equally to spherical area  $4\pi d^2$   
*d = distance = radius*

- ❑ The received power depends upon the wavelength

- ❑ If the Receiver collects power from area  $A_R$ :

$$P_R = P_T G_T \frac{1}{4\pi d^2} A_R$$

- ❑ Receiving Antenna Gain

$$G_R = \frac{4\pi}{\lambda^2} A_R$$

$$P_R = P_T G_T G_R \left(\frac{\lambda}{4\pi d}\right)^2$$

- ❑ This is known as **Frii's Law**.  
Attenuation in free space increases with frequency.

## Student Questions

- ❑ Does the formula give us the power in Watts or dB?  
*Whenever you see a multiplication or division, you know it is Watts. dBs can't be multiplied.*
- ❑ Where does the formula here for  $G_R$  come from?  
*See the reading list.*
- ❑ Is d diameter or radius?  
*d is distance = radius*

- 
- ❑ How to define free space? Is there an example to show that the attenuation increases in real life?

*The effect is seen in every wave transmission. Although sound or water waves are not electromagnetic, their attenuation increases with distance.*

# Multipath

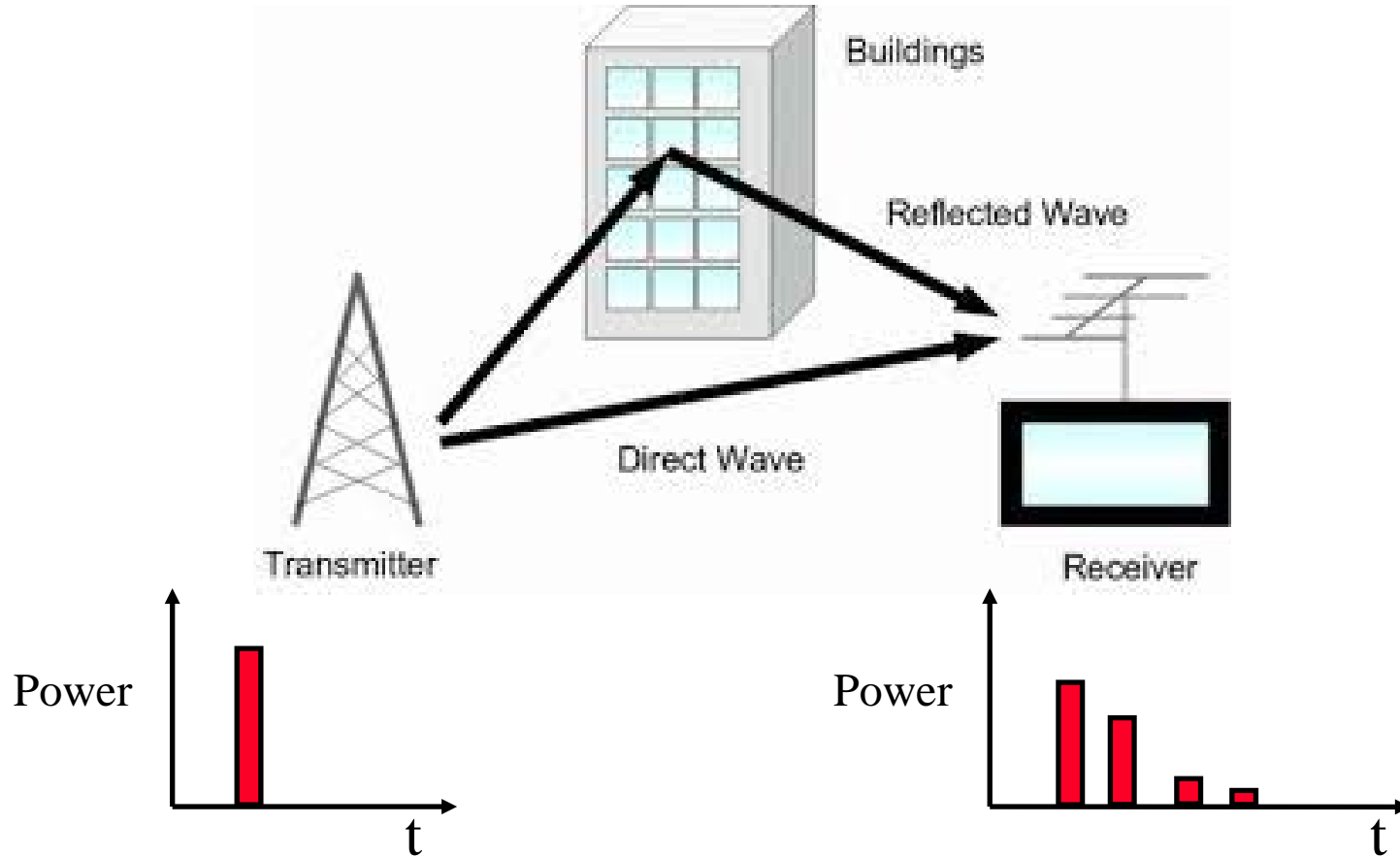

- ❑ Multiple reflected copies of the signal are received

## Student Questions

- ❑ What is the point of this? Is the reflected wave compared to the direct wave to verify integrity?

*What you receive is very different from what was transmitted. So you must find the real signal from this "noisy" signal.*

- ❑ What is the Y axis in the figure?

*Power*

- ❑ How does the receiver decide whether it is receiving waves from a different source or a single wave with its multipath?

*Receivers get a mixture and generally do not distinguish the source. Different sources should ideally use different frequencies.*

---

# Inter-Symbol Interference

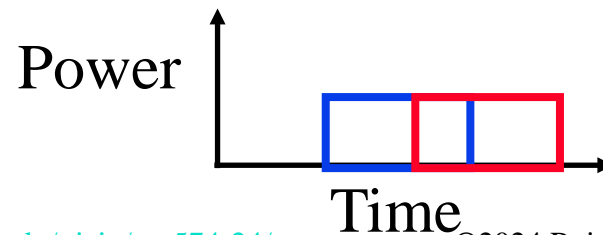
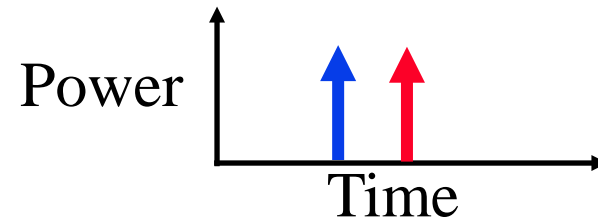
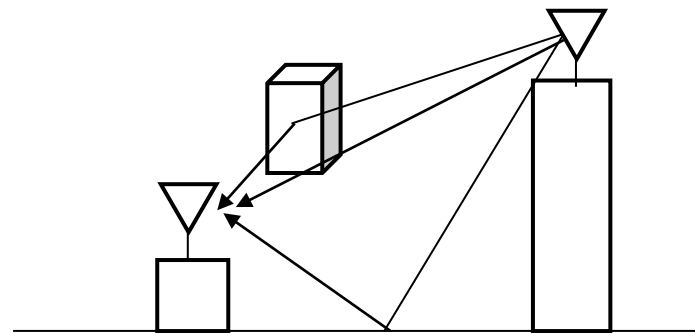

- ❑ Symbols become wider  
⇒ Limits the number of bits/s

## Student Questions

- ❑ Is inter-symbol interference due only to having multiple signals in a space, or could it be due to differing mediums?

*This is how waves propagate. The pulses become wider and run into each other. In some media, it happens faster (higher dispersion index).*

- ❑ The people are analogous to the symbols; what is analogous to the tunnel?

*Medium. This applies to the wire, fiber, and wireless.*

- ❑ Is the dispersion of symbols also present in the frequency domain? The Doppler effect is not just due to relative motion but the change of frequency due to multi-path reflections.

*If there is no motion, the multi-path does not change frequency.*

*Time domain dispersion does affect the frequency profile.*

- ❖ Why does having a large symbol duration mean having less ISI?

*Fatter symbols need more inter-symbol gaps to avoid interference.*

# Multipath Propagation

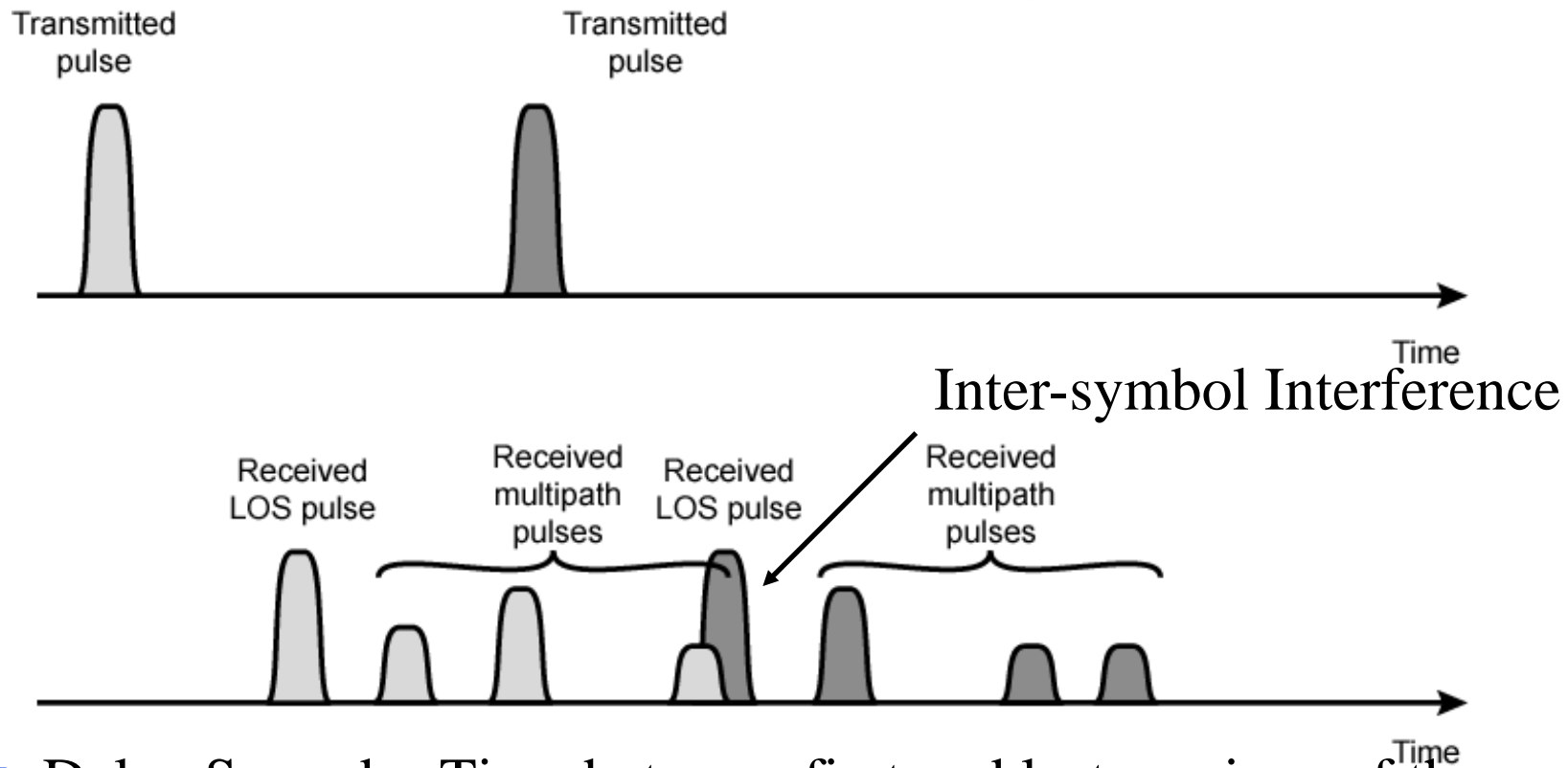

- ❑ Delay Spread = Time between first and last versions of the signal
- ❑ Fading: Fluctuation in amplitude, phase, or delay spread
- ❑ Multipath may add constructively or destructively  
⇒ Fast fading

## Student Questions

- ❑ What are fast fading and slow fading?

*Fast = high frequency*

*Slow = low frequency*

*See Slide 4-15*

- ❑ How do we usually solve ISI?

*By design and computation.*

# $d^{-4}$ Power Law

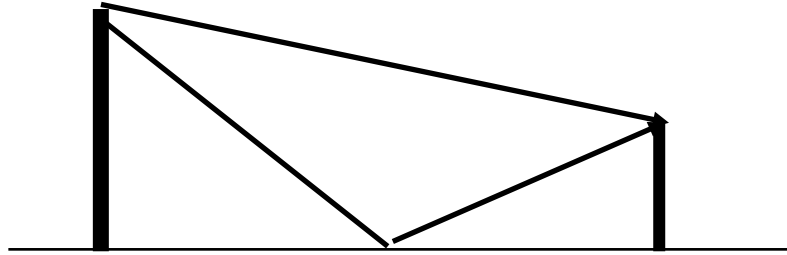

- Using a two-ray model

$$P_R = P_T G_T G_R \left( \frac{h_t h_r}{d^2} \right)^2$$

- Here,  $h_T$  and  $h_R$  are heights of transmit and receive antennas
- It is valid for distances larger than

$$d_{\text{break}} = 4h_T h_R / \lambda$$

- Note that the received power becomes independent of the frequency:  $P \propto d^{-n}$
- Measured results show  $n=1.5$  to  $5.5$ . Typically,  $4$ .

## Student Questions

- How can the received power be independent of frequency? I thought they were always correlated.

*You are right up to break.*

*And I am assuming antennas in free space.*

- Can you please explain what  $n$  is in this slide?

*Negative Power of  $d$*

- When do we use this law?

*When planning for tower placement.*

*❖ How to correctly use the  $d^{-4}$  law?*

*Whenever you want to determine the height and reach of the tower, you use this  $P_R$  formula. See homework 4*

---

# Small Scale Fading

- The signal amplitude can change by moving a few inches  $\Rightarrow$  Small scale fading

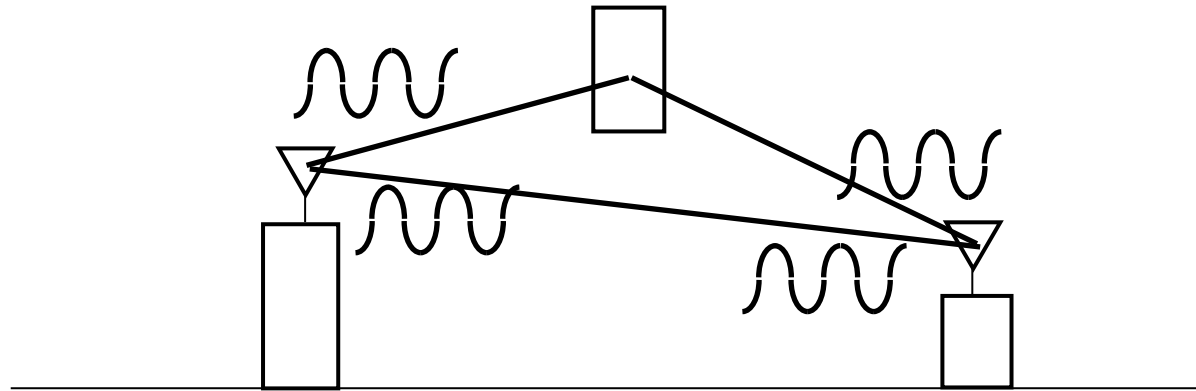

$$\begin{array}{c} \text{~} \\ \text{~} \\ \text{~} \\ + \\ \text{~} \\ \text{~} \\ \text{~} \\ = \\ \text{~} \\ \text{~} \\ \text{~} \end{array}$$

$$\begin{array}{c} \text{~} \\ \text{~} \\ \text{~} \\ + \\ \text{~} \\ \text{~} \\ \text{~} \\ = \\ \text{—} \end{array}$$

## Student Questions

# Shadowing

- Shadowing gives rise to large scale fading

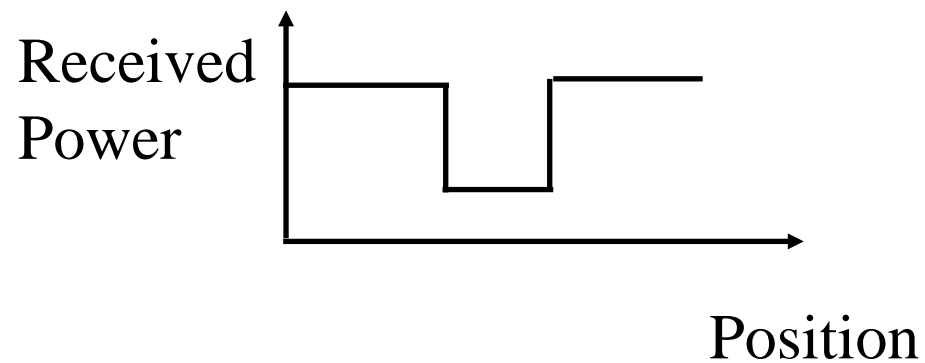
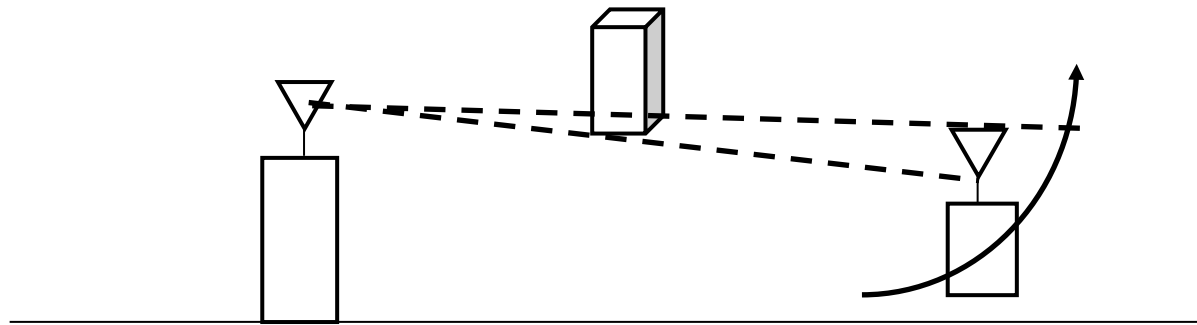

## Student Questions



# Total Path Loss

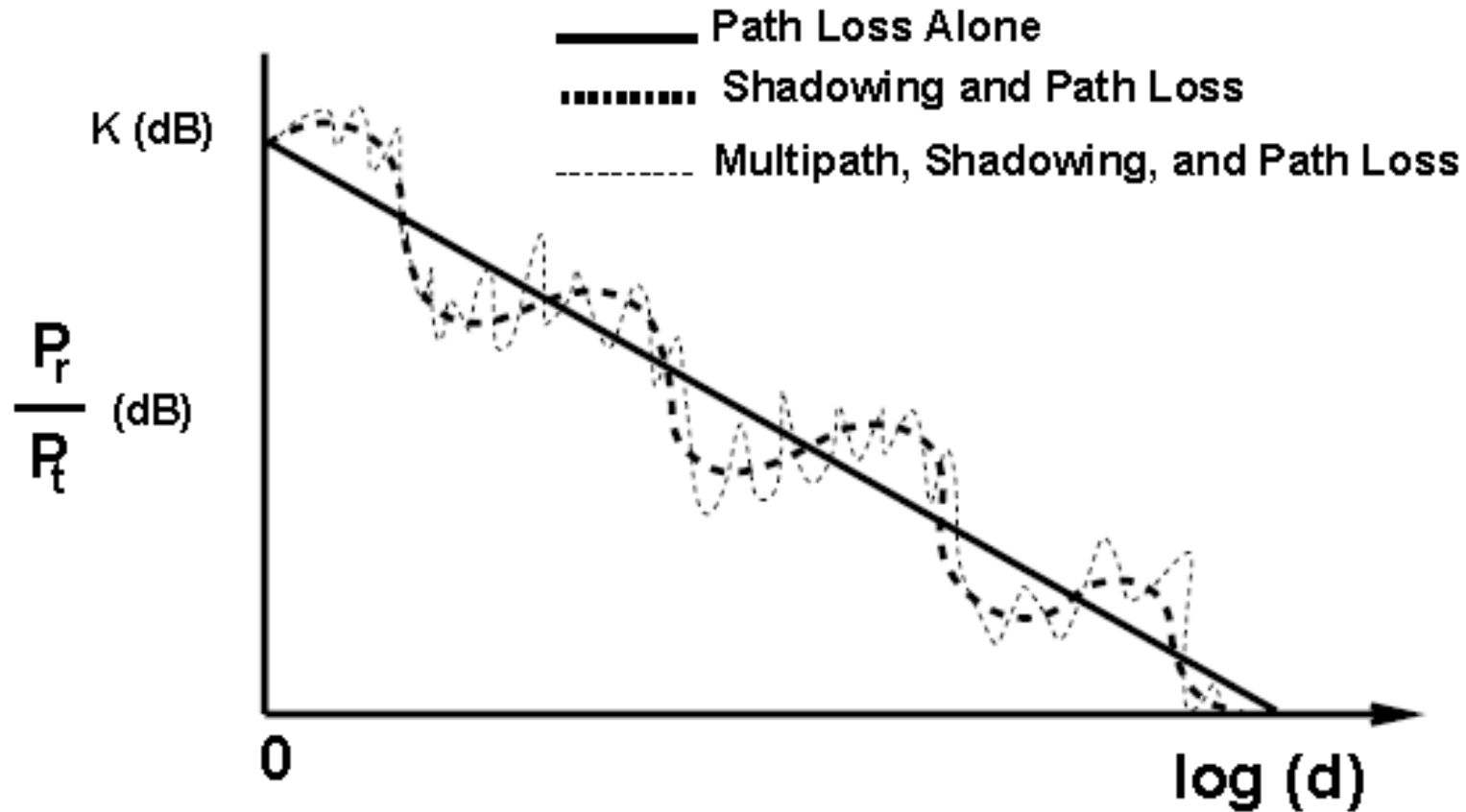

## Student Questions

# Fresnel Zones

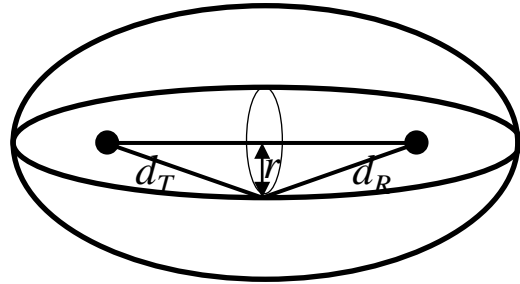

- ❑ Draw an ellipsoid with BS and MS as Foci
- ❑ All points on the ellipsoid have the same BS-MS run length
- ❑ Fresnel ellipsoids = Ellipsoids for which run length = LoS +  $i\lambda/2$
- ❑ At the Fresnel ellipsoids results in a phase shift of  $i\pi$
- ❑ Radius of the  $i^{\text{th}}$  ellipsoid at a distance  $d_T$  from the transmitter and  $d_R$  from the receiver is
 
$$r_i \approx \sqrt{\frac{i\lambda d_T d_R}{d_T + d_R}}$$
- ❑ Free space ( $d^2$ ) law is followed up to the distance at which the first Fresnel Ellipsoid touches the ground

## Student Questions

- ❑ Can you repeat how the ellipsoid relates to the positions of the transmitters?

*A circle has one center. An ellipse has two "foci." The ellipse is in 2D. The Ellipsoid is in 3D. The Fresnel zone is an ellipsoid with foci at the transmitter and receiver antenna.*

- ❑ Can you go over the purpose of a Fresnel Zone? I get the formula, but what is the theoretical purpose of it?

*Any objects in the zone will reduce the signal even if they are not in the straight line joining the two antennas.*

- ❑ What is the radius that the 5th bullet point refers to? Would that formula be used to solve for  $i$ ?

*See the updated figure.*

- ❑ What is the '1' in the equation of point #5?

*See the updated formula.*

- ❑ Slide 16 was vague. Could you please explain it again?

- 
- ❑ Does Fresnel Zones use for determine what in ellipsoid affecting the LOS signal strength?

*Yes. Antenna at lower heights transmit less signal.*

# Multi-Antenna Systems

- ❑ Receiver Diversity
- ❑ Transmitter Diversity
- ❑ Beam forming
- ❑ MIMO

## Student Questions

# Receiver Diversity

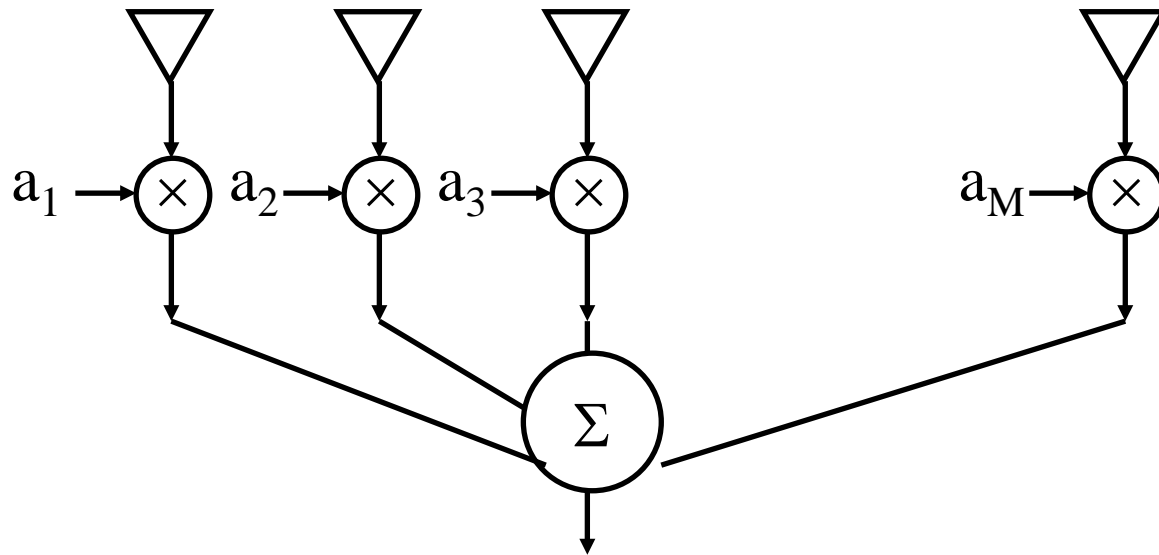

- ❑ User multiple receive antenna
- ❑ Selection combining: Select the antenna with the highest SNR
- ❑ Threshold combining: Select the first antenna with SNR above a threshold
- ❑ Maximal Ratio Combining: The phase is adjusted so that all signals have the same phase. Then, the weighted sum is used to maximize SNR

## Student Questions

- ❑ Is Maximal Ratio Combining a better way than Select and Threshold combining? Or are they used in different situations?  
*Each has a different cost. So, these are used based on cost/performance tradeoffs.*

# Transmitter Diversity

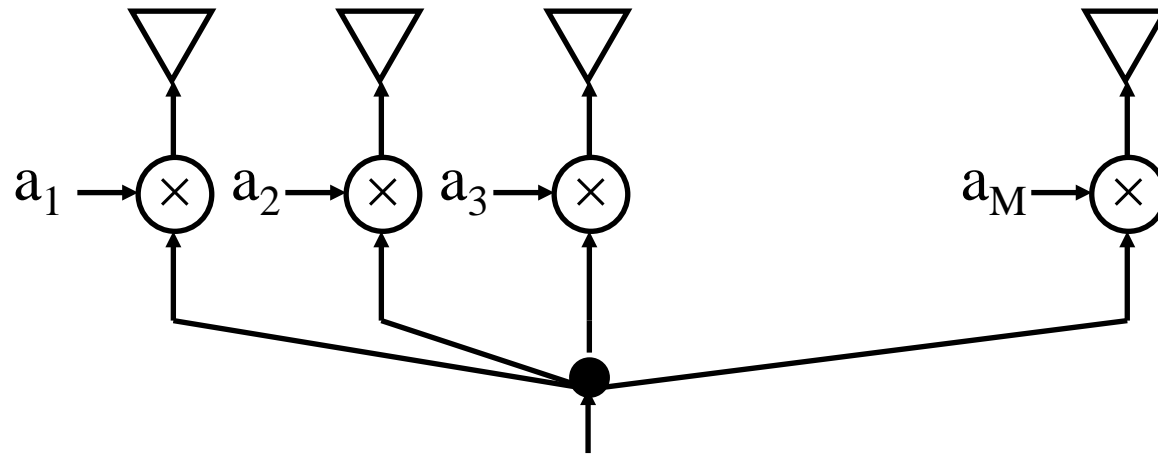

- ❑ Use multiple antennas to transmit the signal. Ample space, power, and processing capacity at the transmitter (but not the receiver).
- ❑ If the channel is known, phase each component and weight it before transmission so that they arrive in phase at the receiver and maximize SNR
- ❑ If the channel is not known, use space-time block codes

## Student Questions

- ❑ What is Ample space?  
*ample = sufficient, a lot*
  - ❑ Is receiver and transceiver diversity similar to how a load balancer works for handling network traffic?  
*Load balancers are used for wired traffic. Diversity shown here is used to increase the data rate. Most current routers use multiple antenna.*
  - ❑ How is the rotation angle of the user's antenna array calculated concerning the moving direction?  
*Rotation is another complexity. Too complex for this course.*
- 
- ❑ What is the purpose of using space-time block codes when the channel is unknown.  
*To characterize the channel.*
  - ❑ How do the space-time block codes improve signal transmission in a multi-antenna system?  
*By constructively combining multiple copies of the signal.*

# Beam forming

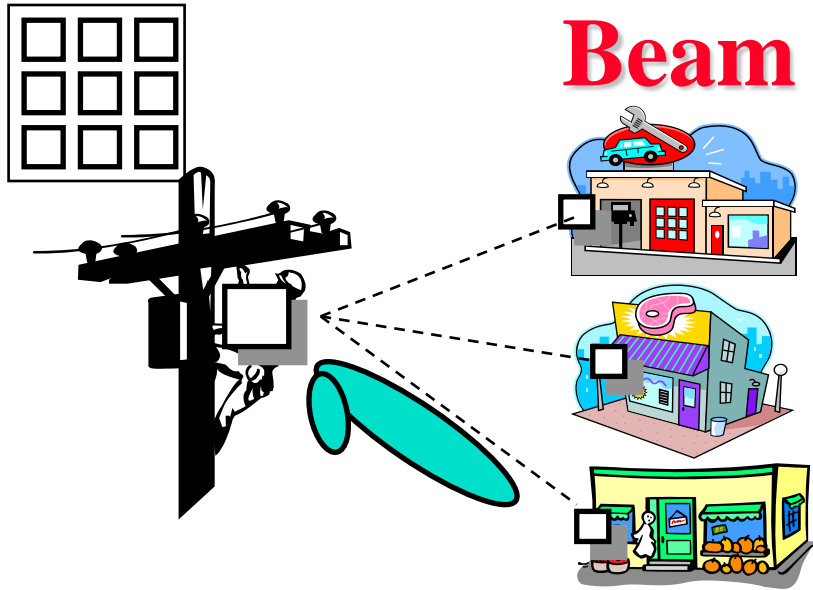

- ❑ Phased Antenna Arrays:  
Receive the same signal using multiple antennas
- ❑ By phase-shifting various received signals and then summing  $\Rightarrow$  Focus on a narrow directional beam
- ❑ Digital Signal Processing (DSP) is used for signal processing  $\Rightarrow$  Self-aligning

## Student Questions

- ❑ Why are there 9 antennas? 3 for each receiver?  
*The 9 dots on the top house are window panes. Not antenna.*
- ❑ Is beam forming done only at the receiver?  
*At the transmitter*

# MIMO



- ❑ Multiple Input Multiple Output
- ❑ RF chain for each antenna  
⇒ Simultaneous reception or transmission of multiple streams

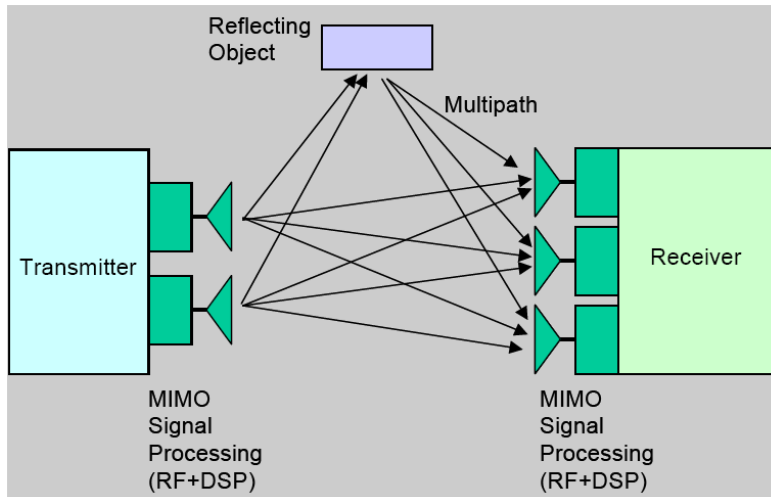

2x3

802.16e at 2.5 GHz, 10 MHz TDD, D:U=2:1

T:R	1x1	1x2	2x2	2x4	4x2	4x4
b/Hz	1.2	1.8	2.8	4.4	3.7	5.1

## Student Questions

- ❑ I noticed the router on the slide. Are the multiple antennae on this kind of router strictly for MIMO? If it is the transmitter, is “T” in “T: R” always 3.?

*Yes, multiple antennas are for MIMO. No, it is not always 3. It can be any number.*

- ❑ From my understanding, MIMO is a form of transmitter diversity, so what is the difference?

*MIMO = Transmitter diversity + receiver diversity*

- ❑ What is D: U, and how does it affect the b/Hz?

*D=Down power*

*U=Up power*

- ❑ Is MIMO related to OFDM?

*No. MIMO is an older concept than OFDM. MIMO is in space. OFDM is in frequency.*

# Multiple Access Methods

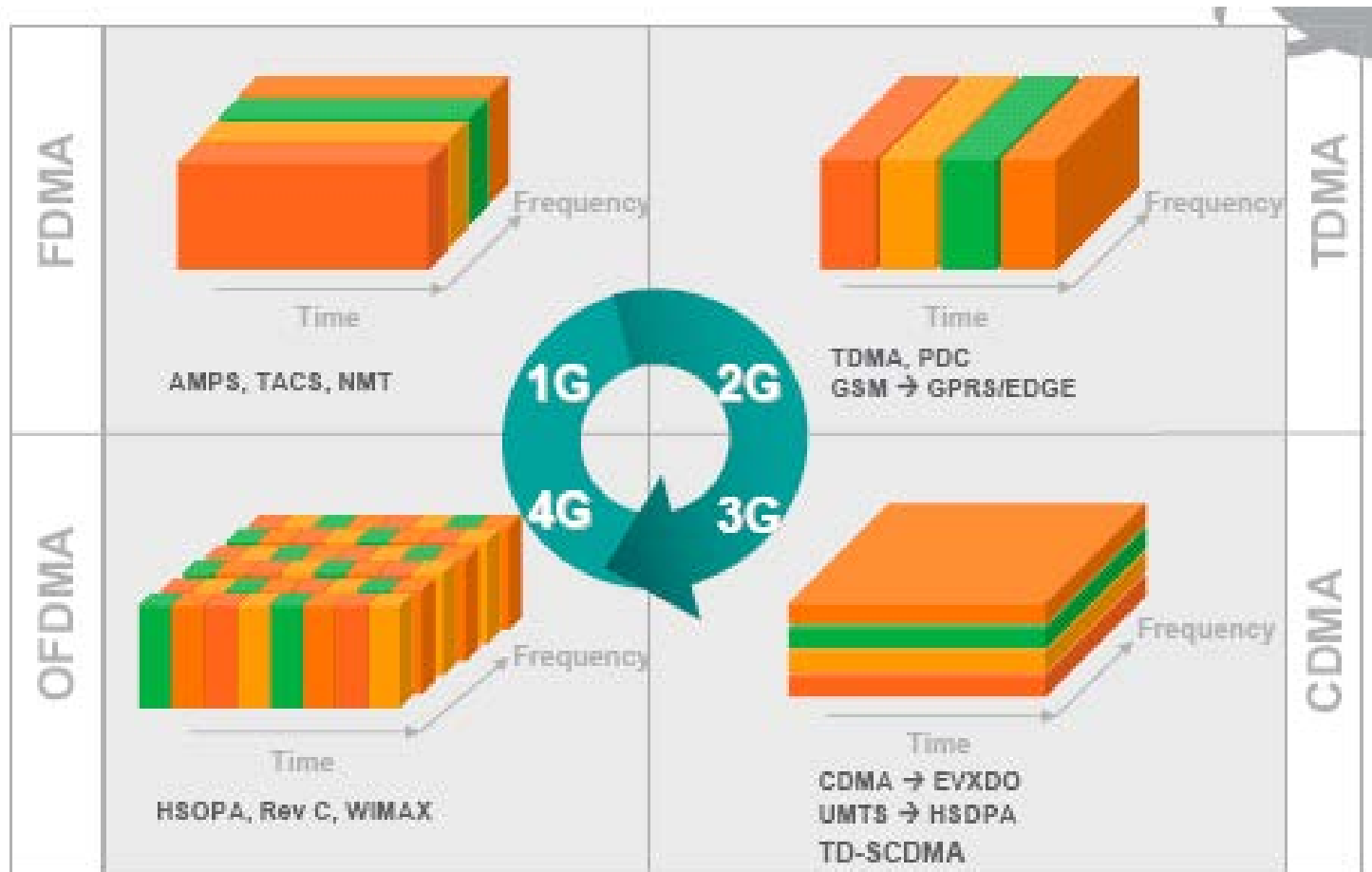

## Student Questions

- How does 5G compare?  
*It is similar to 4G (OFDMA) but significantly improved. Wait for the last module of this course.*
- What's the speed difference among these generations?  
*Generally, a factor of 10.*
- Does 5G also do OFDMA?  
*Yes.*

Source: Nortel



# OFDM

- ❑ Orthogonal Frequency Division Multiplexing
- ❑ Ten 100 kHz channels are better than one 1 MHz Channel  
⇒ Multi-carrier modulation

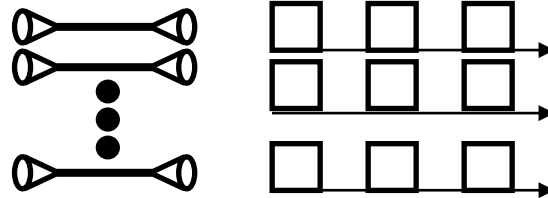
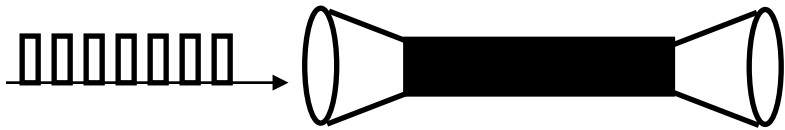

- ❑ Frequency band is divided into 256 or more sub-bands.  
Orthogonal ⇒ Peak of one at the null of others
- ❑ Each carrier is modulated with a BPSK, QPSK, 16-QAM, 64-QAM, etc., depending on the noise (Frequency selective fading)
- ❑ Used in 802.11a/g, 802.16,  
Digital Video Broadcast handheld (DVB-H)
- ❑ Easy to implement using FFT/IFFT

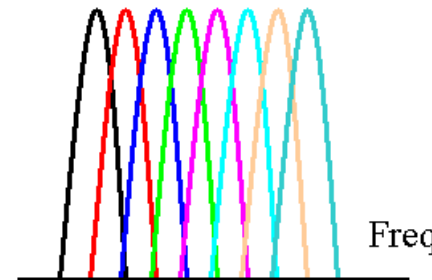
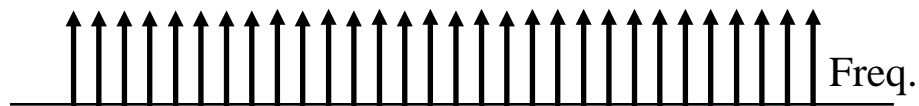

## Student Questions

- ❑ What is multi-carrier modulation?  
*Multicarrier = multiple frequency signals.*
- ❑ What is the input to FFT, and what is the output of it?  
*FFT: Time domain to Frequency domain*  
*IFFT: Frequency domain to time domain*

# Advantages of OFDM

- ❑ Easy to implement using FFT/IFFT.  
FFT/IFFT are implemented only as powers of 2 (256, 1024, ...)
- ❑ Computational complexity =  $O(B \log BT)$  compared to previous  $O(B^2T)$  for Equalization. Here, B is the bandwidth, and T is the delay spread.
- ❑ Graceful degradation if an excess delay
- ❑ Robustness against frequency selective burst errors
- ❑ Allows adaptive modulation and coding of subcarriers
- ❑ Robust against narrowband interference (affecting only some subcarriers)
- ❑ Allows **pilot** subcarriers for channel estimation

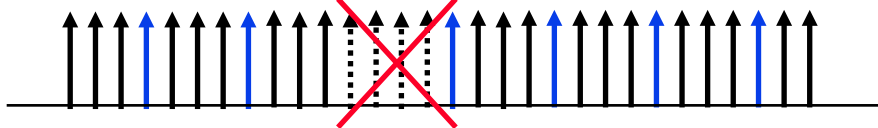

## Student Questions

- ❑ Why does OFDM have graceful degradation?  
*Because there are multiple carriers. Not all carriers get damaged or equally damaged.*
  - ❑ What is Equalization?  
*Frequency-specific amplification.*
-

# OFDM: Design considerations

- ❑ A large number of carriers  $\Rightarrow$  Smaller data rate per carrier  $\Rightarrow$  Larger symbol duration  $\Rightarrow$  Less inter-symbol interference
- ❑ Reduced subcarrier spacing  $\Rightarrow$  Increased inter-carrier interference due to Doppler spread in mobile applications
- ❑ Easily implemented as Inverse Discrete Fourier Transform (IDFT) of the data symbol block
- ❑ Fast Fourier Transform (FFT) is a computationally efficient way of computing DFT

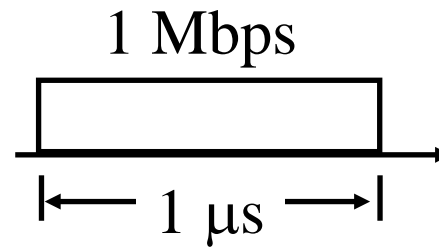
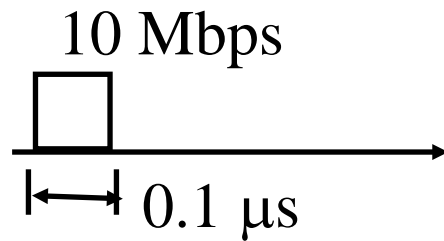

## Student Questions

- ❑ So, do we have an increase in inter-carrier interference and a decrease in inter-symbol interference simultaneously? Is there a trade-off here?

*If carriers are close, there is inter-carrier interference, and the symbols are larger,  $\Rightarrow$  Less Inter-symbol interference. These affect the design.*

*A 0.5 ms spreading of 0.1 ms will result in the total obliteration of the data, and a 0.5  $\mu$ s spreading of a 1  $\mu$ s symbol will result in a 50% loss of efficiency.*

---

# OFDMA

- ❑ Orthogonal Frequency Division Multiple Access
- ❑ OFDM is modulation into multiple frequency subcarriers.
- ❑ OFDMA is allocation of those subcarriers among users.
- ❑ Each user has a subset of subcarriers for a few slots
- ❑ OFDMA allows Time + Freq DMA  $\Rightarrow$  2D Scheduling

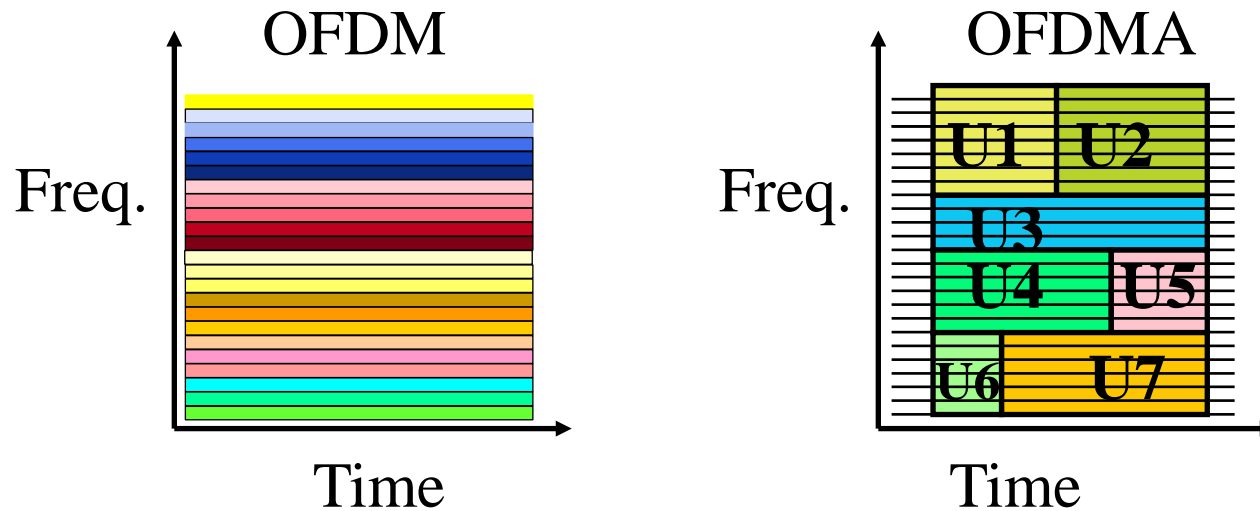

## Student Questions

- ❑ What do you mean by 'Each user has a subset of subcarriers for a few slots'?
- As shown by colored rectangles in the right diagram.*
- ❖ Can we say OFDM uses OFDMA whereas TDMA uses FDMA + TDMA
- OFDM=Orthogonal subcarriers with TDMA*  
*OFDMA= Orthogonal subcarriers with FDMA+TDMA*  
*FD=Frequency Division of the band into subcarriers*

- ❑ Is the OFDM, all users share the same frequency domain by operate in different time domain.

*OFDM does not say how to divide the resources among users. All it says is that the frequency band is divided in to smaller channels. The figures shows users get the whole band for a certain time. This is not necessary.*

# Scalable OFDMA (SOFDMA)

- ❑ OFDM symbol duration =  $f(\text{subcarrier spacing})$
  - ❑ Subcarrier spacing = Frequency bandwidth/Number of subcarriers
  - ❑ Frequency bandwidth = 1.25 MHz, 3.5 MHz, 5 MHz, 10 MHz, 20 MHz, etc.
  - ❑ Symbol duration affects higher-layer operation
    - ⇒ Keep symbol duration constant at 102.9  $\mu\text{s}$
    - ⇒ Keep subcarrier spacing 10.94 kHz
    - ⇒ Number of subcarriers  $\propto$  Frequency bandwidth
- This is known as scalable OFDMA.

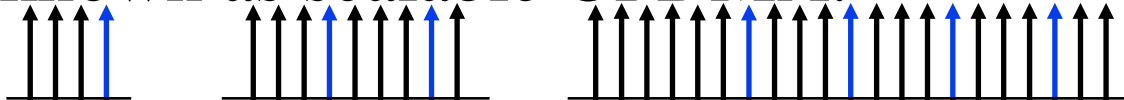

## Student Questions

- ❑ What is the advantage of SOFDMA over OFDMA? Why does 102.9  $\mu\text{s}$  correspond to 10.94 kHz?

*This is an example. 10.94 kHz with 128 FFT was used in Mobile WiMAX for 1.25 MHz.*

- ❖ 10.94 kHz with 128 FFT was used in Mobile WiMAX for 1.25 MHz. How is this possible?

*$1.25 \text{ MHz} / 10.94 \text{ kHz} = 114.26$*

*$\Rightarrow 114 \text{ subcarriers} \Rightarrow 128 \text{ FFT}$*

---

# Effect of Frequency

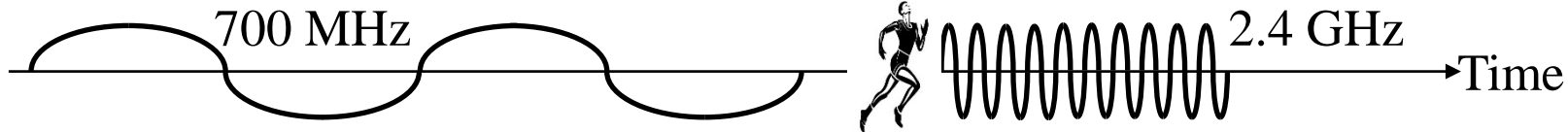

- ❑ Higher Frequencies have a higher attenuation, e.g., 18 GHz has 20 dB/m more than 1.8 GHz
- ❑ Higher frequencies need a smaller antenna  
Antenna  $\geq$  Wavelength/2, 800 MHz  $\Rightarrow$  6"
- ❑ Higher frequencies are affected more by weather  
Higher than 10 GHz affected by rainfall  
60 GHz affected by absorption of oxygen molecules
- ❑ Higher frequencies have more bandwidth and higher data rate
- ❑ Higher frequencies allow more frequency reuse  
They attenuate close to cell boundaries. Low frequencies propagate far.

## Student Questions

- ❑ Another course taught that antenna size should be wavelength/4. I wonder which one is correct, a factor of 2 or 4?

*$\lambda/2$  is correct.*

# Effect of Frequency (Cont)

- ❑ Lower frequencies have a longer reach
  - ⇒ Longer Cell Radius
  - ⇒ Good for rural areas
  - ⇒ Smaller number of towers
  - ⇒ Longer battery life
- ❑ Lower frequencies require larger antenna and antenna spacing
  - ⇒ MIMO is difficult, particularly on mobile devices
- ❑ Lower frequencies ⇒ Smaller channel width
  - ⇒ Need aggressive modulation coding scheme (MCS), e.g., 256-QAM
- ❑ Doppler shift =  $vf/c$  = Velocity × Frequency / (speed of light)
  - ⇒ Lower Doppler spread at lower frequencies
- ❑ Mobility ⇒ Below 10 GHz

## Student Questions

- ❑ Why does a low frequency mean low channel width? Suppose we use 10 MHz to 100 MHz. Isn't it possible theoretically?  
*Each frequency band has a different behavior. You do not cross bands. So, it is impossible to give 1000 MHz in a 700 MHz band.*
  - ❑ what is MCS?  
*Modulation coding scheme*
  - ❑ Why do lower frequencies have longer battery life? Is this related to the power required to reach a certain distance?  
 $P_r = P_t G_t G_r (\lambda/4\pi d)^2$   
*More power received at large  $\lambda$*
  - ❖ Why does mobility require below 10 GHz?  
*Doppler spread*
-

# Summary

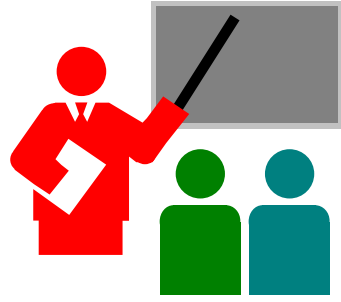

1. Path loss increases at a power of 2 to 5.5 with distance.
2. Fading = Changes in power changes in position
3. Fresnel zones = Ellipsoid with a distance of  $LoS + i\lambda/2$   
Any obstruction of the first zone will increase path loss
4. Multiple Antennas: Receive diversity, transmit diversity, Smart Antenna, MIMO
5. OFDM splits a band into many orthogonal subcarriers.  
OFDMA = FDMA + TDMA

## Student Questions



# Homework 4

- A. Determine the mean received power at a subscriber station (SS). The channel between a base station at 14 m and the subscriber stations at 4 m at a distance of 500 m. The Transmitter and Receiver antenna gains are 10 dB and 5 dB, respectively. Use a power exponent of 4. The transmitted power is 30 dBm. Do All calculations using dB and dBm.
- B. With a subcarrier spacing of 10 kHz, how many subcarriers will be used in a system with 8 MHz channel bandwidth, and what size FFT will be used?
- C. In a scalable OFDMA system, the number of carriers for a 10 MHz channel is 1024. How many carriers will be used if the channel is 1.25 MHz, 5 MHz, or 8.75 MHz?

## Student Questions

- Part A. Does SS refer to the subscriber station?

*Yes.*

- Part A. In the exam, will you mention which power exponent to use explicitly?

*Use four if not given.*

- ❖ Can you please go over the solution to Homework 4?

*Sure.*

- ❖ Part A: What does it mean to do all calculations in DB?

*Use a log scale only. Add. Do not multiply.*

- ❖ I googled it, and it said dB and dBm could not be converted to each other; dB is just a ratio, and only dBm can be converted to watts and refer to power. Is it correct? If so, how can the dB be used to calculate S/N? How can the dB be directly used to calculate the solution?

*The difference between two dBm is dB. A subtraction in a log scale results in a ratio.*

---

# Reading List

- ❑ Jim Geier, "Radio Wave Fundamentals," Chapter 2 in his book "Designing and Deploying 802.11 Wireless Networks: A Practical Guide to Implementing 802.11n and 802.11ac Wireless Networks, Second Edition," Cisco Press, May 2015, 600 pp., ISBN:1-58714-430-1 (Safari Book), Chapter 2.
- ❑ Raj Jain, "Channel Models: A Tutorial," WiMAX Forum AATG, February 2007, first 7 of 21 pages, [http://www.cse.wustl.edu/~jain/wimax/channel\\_model\\_tutorial.htm](http://www.cse.wustl.edu/~jain/wimax/channel_model_tutorial.htm)
- ❑ Jim Geier, "Wireless Networks first-step," Cisco Press, August 2004, 264 pp., ISBN:1-58720-111-9 (Safari Book), Chapter 3.
- ❑ Steve Rackley, "Wireless Networking Technology," Newnes, March 2007, 416 pp., ISBN:0-7506-6788-5 (Safari Book), Chapter 4.
- ❑ Stephan Jones; Ronald J. Kovac; Frank M. Groom, "Introduction to Communications Technologies, 3rd Edition," CRC Press, July 2015, 364 pp., ISBN:978-1-4987-0295-9 (Safari Book), Chapters 3 and 4.

## Student Questions

# Wikipedia Links

- ❑ [https://en.wikipedia.org/wiki/Omnidirectional\\_antenna](https://en.wikipedia.org/wiki/Omnidirectional_antenna)
- ❑ [https://en.wikipedia.org/wiki/Antenna\\_gain](https://en.wikipedia.org/wiki/Antenna_gain)
- ❑ [https://en.wikipedia.org/wiki/Equivalent\\_isotropically\\_radiated\\_power](https://en.wikipedia.org/wiki/Equivalent_isotropically_radiated_power)
- ❑ [https://en.wikipedia.org/wiki/High-gain\\_antenna](https://en.wikipedia.org/wiki/High-gain_antenna)
- ❑ [https://en.wikipedia.org/wiki/Signal\\_reflection](https://en.wikipedia.org/wiki/Signal_reflection)
- ❑ <https://en.wikipedia.org/wiki/Scattering>
- ❑ [https://en.wikipedia.org/wiki/Path\\_loss](https://en.wikipedia.org/wiki/Path_loss)
- ❑ [https://en.wikipedia.org/wiki/Free-space\\_path\\_loss](https://en.wikipedia.org/wiki/Free-space_path_loss)
- ❑ [https://en.wikipedia.org/wiki/Log-distance\\_path\\_loss\\_model](https://en.wikipedia.org/wiki/Log-distance_path_loss_model)
- ❑ [https://en.wikipedia.org/wiki/Multipath\\_propagation](https://en.wikipedia.org/wiki/Multipath_propagation)
- ❑ [https://en.wikipedia.org/wiki/Multipath\\_interference](https://en.wikipedia.org/wiki/Multipath_interference)
- ❑ [https://en.wikipedia.org/wiki/Intersymbol\\_interference](https://en.wikipedia.org/wiki/Intersymbol_interference)
- ❑ <https://en.wikipedia.org/wiki/Fading>
- ❑ [https://en.wikipedia.org/wiki/Shadow\\_fading](https://en.wikipedia.org/wiki/Shadow_fading)
- ❑ [https://en.wikipedia.org/wiki/Fresnel\\_zone](https://en.wikipedia.org/wiki/Fresnel_zone)

## Student Questions

# Wikipedia Links (Cont)

- ❑ [https://en.wikipedia.org/wiki/Antenna\\_diversity](https://en.wikipedia.org/wiki/Antenna_diversity)
- ❑ <https://en.wikipedia.org/wiki/Beamforming>
- ❑ [https://en.wikipedia.org/wiki/Antenna\\_array\\_\(electromagnetic\)](https://en.wikipedia.org/wiki/Antenna_array_(electromagnetic))
- ❑ [https://en.wikipedia.org/wiki/Phased\\_array](https://en.wikipedia.org/wiki/Phased_array)
- ❑ [https://en.wikipedia.org/wiki/Smart\\_antenna](https://en.wikipedia.org/wiki/Smart_antenna)
- ❑ [https://en.wikipedia.org/wiki/Multiple-input\\_multiple-output\\_communications](https://en.wikipedia.org/wiki/Multiple-input_multiple-output_communications)
- ❑ [https://en.wikipedia.org/wiki/Diversity\\_combining](https://en.wikipedia.org/wiki/Diversity_combining)
- ❑ [https://en.wikipedia.org/wiki/Maximal-ratio\\_combining](https://en.wikipedia.org/wiki/Maximal-ratio_combining)
- ❑ [https://en.wikipedia.org/wiki/Orthogonal\\_frequency-division\\_multiplexing](https://en.wikipedia.org/wiki/Orthogonal_frequency-division_multiplexing)
- ❑ [https://en.wikipedia.org/wiki/Orthogonal\\_frequency-division\\_multiple\\_access](https://en.wikipedia.org/wiki/Orthogonal_frequency-division_multiple_access)

## Student Questions

# Acronyms

- ❑ BPSK Binary Phase-Shift Keying
- ❑ BS Base Station
- ❑ dB DeciBels
- ❑ dBi DeciBels Intrinsic
- ❑ dBm DeciBels milliwatt
- ❑ DFT Discrete Fourier Transform
- ❑ DMA Direct Memory Access
- ❑ DSP Digital Signal Processing
- ❑ DVB-H Digital Video Broadcast handheld
- ❑ FDMA Frequency Division Multiple Access
- ❑ FFT Fast Fourier Transform
- ❑ IDFT Inverse Discrete Fourier Transform
- ❑ IFFT Inverse Fast Fourier Transform
- ❑ ISI Inter-symbol interference
- ❑ kHz Kilo Hertz
- ❑ LoS Line of Sight

## Student Questions

# Acronyms (Cont)

- ❑ MHz      Mega Hertz
- ❑ MIMO     Multiple Input Multiple Output
- ❑ MS        Mobile Station
- ❑ OFDM     Orthogonal Frequency Division Multiplexing
- ❑ OFDMA    Orthogonal Frequency Division Multiple Access
- ❑ QAM       Quadrature Amplitude Modulation
- ❑ QPSK     Quadrature Phase-Shift Keying
- ❑ RF        Radio Frequency
- ❑ SNR       Signal to Noise Ratio
- ❑ SS        Subscriber Station
- ❑ TDMA     Time Division Multiple Access

## Student Questions

**Scan This to Download These Slides**



Raj Jain

<http://rajjain.com>

[http://www.cse.wustl.edu/~jain/cse574-24/j\\_04wsp.htm](http://www.cse.wustl.edu/~jain/cse574-24/j_04wsp.htm)

**Student Questions**

# Related Modules



CSE567M: Computer Systems Analysis (Spring 2013),  
[https://www.youtube.com/playlist?list=PLjGG94etKypJEKjNAa1n\\_1X0bWWNyZcof](https://www.youtube.com/playlist?list=PLjGG94etKypJEKjNAa1n_1X0bWWNyZcof)

CSE473S: Introduction to Computer Networks (Fall 2011),  
[https://www.youtube.com/playlist?list=PLjGG94etKypJWOSPMh8Azcg5e\\_10TiDw](https://www.youtube.com/playlist?list=PLjGG94etKypJWOSPMh8Azcg5e_10TiDw)



Recent Advances in Networking (Spring 2013),  
<https://www.youtube.com/playlist?list=PLjGG94etKypLHyBN8mOgwJLHD2FFIMGq5>

CSE571S: Network Security (Fall 2011),  
<https://www.youtube.com/playlist?list=PLjGG94etKypKvzfVtutHcPFJXumyyg93u>



Video Podcasts of Prof. Raj Jain's Lectures,  
<https://www.youtube.com/channel/UCN4-5wzNP9-ruOzQMs-8NUw>

## Student Questions



# Reflection, Diffraction and Scattering (Cont)

- ❑ **Reflection:** Surface large relative to the wavelength of the signal
  - May have a phase shift from the original
  - May cancel out original or increase it
- ❑ **Diffraction:** Edge of the impenetrable body that is large relative to  $\lambda$ 
  - May receive signal even if there is no line of sight (LOS) to the transmitter
- ❑ **Scattering**
  - Obstacle size on the order of wavelength. Lamp posts, etc.
- ❑ If LOS, diffracted and scattered signals are not significant
  - Reflected signals may be
- ❑ If no LOS, **reflection**, diffraction, and scattering are primary means of reception

## Student Questions

- ❑ Why is scattering a primary reception mean if there is no LOS?  
*Power received = LOS + Reflection, diffraction, and scattering*  
*If one or more are missing, others become the means for a reception.*
-