

# Data-Link Layer and Management Protocols for IoT

Raj Jain  
Washington University in Saint Louis  
Saint Louis, MO 63130  
Jain@cse.wustl.edu

These slides and audio/video recordings of this class lecture are at:  
<http://www.cse.wustl.edu/~jain/cse570-23/>

**Student Questions**



- ❑ Recent Protocols for IoT
- ❑ Power Line Communication (PLC)
- ❑ HomePlug, HomePlug AV, HomePlug AV2, BPL, Netricity
- ❑ IEEE 1905.1 Management, Security, and Configuration
- ❑ Smart Cards

Note: This is part 2 of a series of class lectures on IoT.

Wireless data link protocols are covered in the CSE 574 Wireless Network Class. More protocols are covered in other parts of this series.

## Student Questions

# Recent Protocols for IoT

Session	MQTT, SMQTT, CoRE, DDS, AMQP, XMPP, CoAP, IEC, IEEE 1888, ...	Security	Management		
Network	<b>Encapsulation</b> 6LoWPAN, 6TiSCH, 6Lo, Thread... <b>Routing</b> RPL, CORPL, CARP			IEEE 1888.3, TCG, Oath 2.0, SMACK, SASL, EDSA, ace, DTLS, Dice, ...	IEEE 1905, IEEE 1451, IEEE 1377, IEEE P1828, IEEE P1856
DataLink	Wi-Fi, Bluetooth Low Energy, Z-Wave, ZigBee Smart, DECT/ULE, 3G/LTE, NFC, Weightless, HomePlug GP, 802.11ah, 802.15.4e, G.9959, WirelessHART, DASH7, ANT+, LTE-A, LoRaWAN, ISA100.11a, DigiMesh, WiMAX, ...				

## Student Questions

Can each device use multiple protocols or only one protocol? *Yes. A device can be multi-protocol. For example, both Wi-Fi and Bluetooth. Each device generally needs at least one from each layer.*

Ref: Tara Salman, Raj Jain, "A Survey of Protocols and Standards for Internet of Things," Advanced Computing and Communications, Vol. 1, No. 1, March 2017, [http://www.cse.wustl.edu/~jain/papers/iot\\_accs.htm](http://www.cse.wustl.edu/~jain/papers/iot_accs.htm)

Washington University in St. Louis

<http://www.cse.wustl.edu/~jain/cse570-23/>

©2023 Raj Jain

# L2 Protocols for IoT

Most of the L2 IoT protocols are wireless.

- ❑ **Wireless Protocols:** Wi-Fi, Bluetooth Low Energy, Z-Wave, ZigBee Smart, DECT/ULE, 3G/LTE, NFC, Weightless, IEEE 802.11ah, IEEE 802.15.4, G9959, WirelessHart, DASH7, ANT+, LTE-A, LoraWAN, ISA 100.11a, DigiMesh, etc. These are covered in CSE 574 Wireless and Mobile Networking class.
- ❑ **Wired Protocols:** In this lecture, we cover Powerline Communications (HomePlug GP) and associated management protocols

## Student Questions

- ❑ Why Bluetooth Low Energy is an L2 protocol? Can it work with TCP/IP and other networking protocols?  
*Bluetooth has its layers to the application. But all Bluetooth devices have common L2 layers. Other layers depend upon the application.*
- 

Ref: Raj Jain, "CSE574S: Wireless and Mobile Networking (Spring 2016)," <http://www.cse.wustl.edu/~jain/cse574-16/index.html>

# Power Line Communication (PLC)

- ❑ Started in 1950 for remote ignition and lighting of Street lights. 100 Hz and 1 kHz signals over electrical wires
- ❑ Two-way systems use 3-148.5 kHz to read electric meters, home automation, alarms, etc.

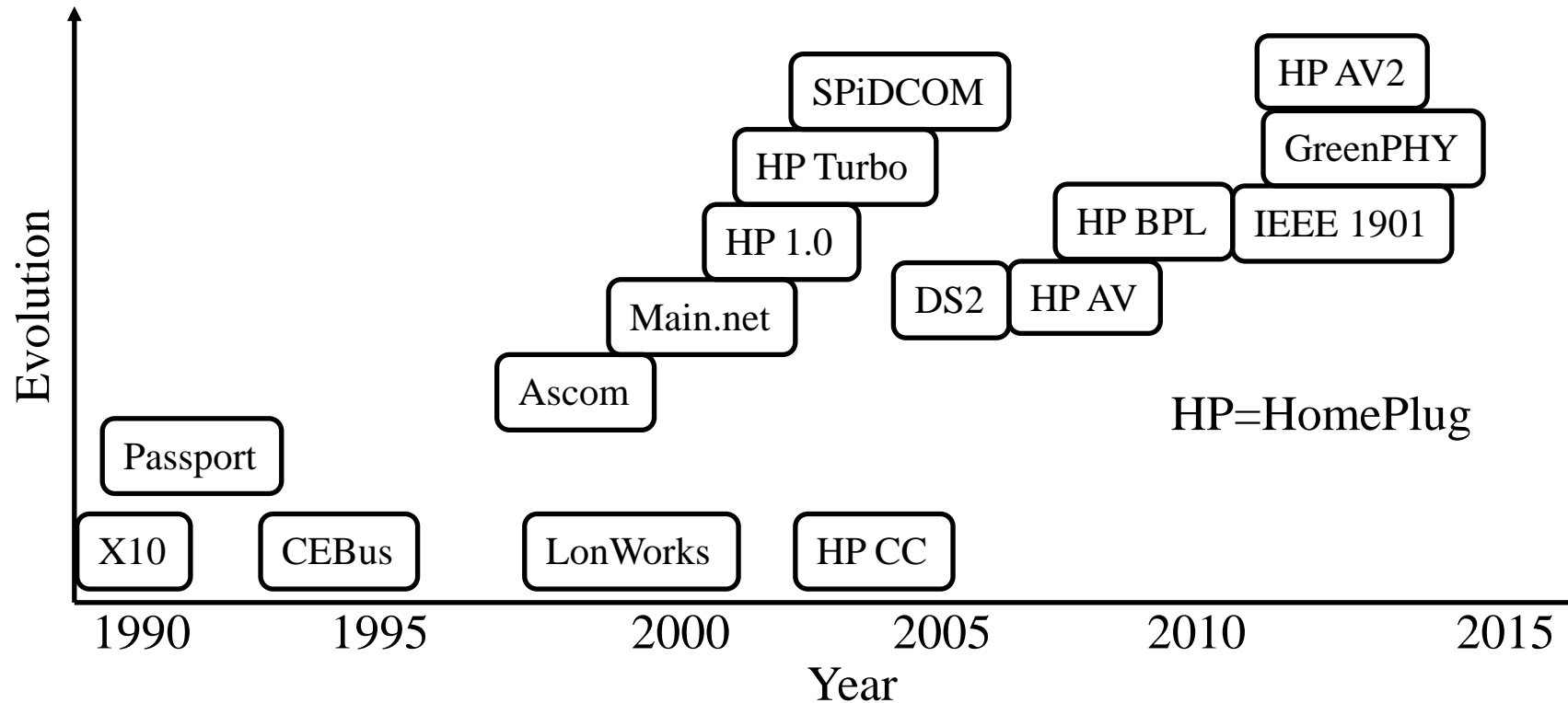

## Student Questions

- ❑ Are we required to read about all the PLCs in this figure? And the difference, by the way, them?

*No. Most of these are historical. The current ones are discussed later in this module.*

Ref: H. Chaouchi, "The Internet of Things: Connecting Objects," Wiley, Jun 2010, 288 pp., ISBN: 9781848211407 (Safari Book)

Washington University in St. Louis

<http://www.cse.wustl.edu/~jain/cse570-23/>

©2023 Raj Jain

# Broadband Over Power Lines (BPL)

- ❑ High-speed internet connection using power lines (like DSL)
- ❑ Also known as HomePlug-BPL.  
Incorporated in IEEE 1901-2010
- ❑ Not cost-competitive with optical fiber or DSL  
⇒ Suitable only for remote locations
- ❑ A high-frequency signal cannot pass through transformers, so the signal has to be bypassed using a repeater
- ❑ In the US, one transformer per house ⇒ Very expensive  
In Europe: 1 transformer per 10-100 houses  
⇒ More cost-effective
- ❑ Radiofrequency interference with existing wireless services is avoided using OFDM

Ref: [http://en.wikipedia.org/wiki/Broadband\\_over\\_power\\_lines](http://en.wikipedia.org/wiki/Broadband_over_power_lines)

Washington University in St. Louis

<http://www.cse.wustl.edu/~jain/cse570-23/>

©2023 Raj Jain

## Student Questions

# OFDM

- ❑ Orthogonal Frequency Division Multiplexing
- ❑ Ten 100 kHz channels are better than one 1 MHz Channel  
⇒ Multi-carrier modulation

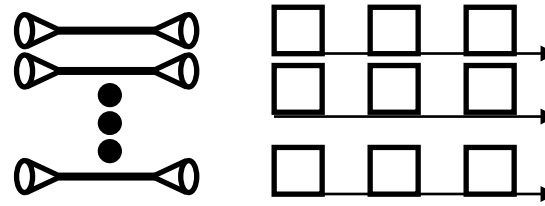
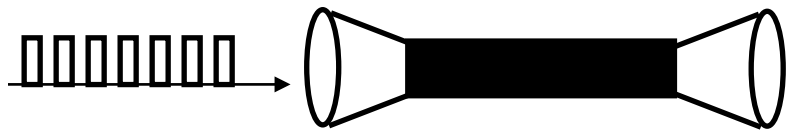

- ❑ The frequency band is divided into 256 or more sub-bands. Orthogonal ⇒ Peak of one at the null of others

- ❑ Each carrier is modulated with a **BPSK** (2bps/Hz), **QPSK** (4 bps/Hz), **16-QAM** (8bps/Hz), **64-QAM** (16 bps/Hz) etc depending on the noise (Frequency selective fading)

- ❑ Used in 802.11a/g, 802.16, Digital Video Broadcast handheld (DVB-H) and

- ❑ Easy to implement using FFT/IFFT

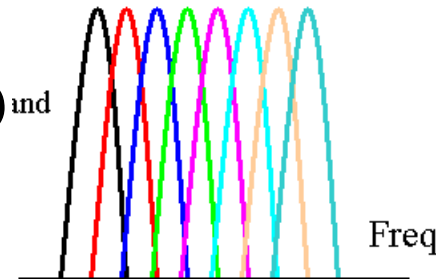

## Student Questions

- ❑ 16-QAM(8bps/hz), can you please clarify the meaning of 16 and 8 ?? and if a factor or equation relates them?

*Quadrature Amplitude Modulation*

$A \sin(2\pi ft + \theta)$ ,  $A$ =Amplitude,  $\theta$ =Phase

$=x+iy$

*16-QAM*

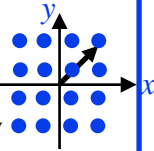

- ❑ What is the noise mean(Frequency selective fading)?

*Signal to Noise ratio (SNR) drops. at a particular frequency range.*

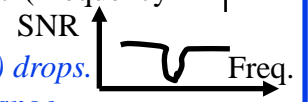

- ❑ It seems like using OFDM can send large amounts of data even in narrow band bandwidth, but does it have any weaknesses?

*There are several extensions, but they are covered in a wireless course. Not here.*

- ❑ Can you give an example of a message sent through this method and how it would be transmitted over OFDM?

*Your 4G phone, DSL both use OFDMA.*

- ❑ Why 100 kHz channels are better than one 1 MHz?

*These are discussed in an EE course on wireless communication.*

# OFDM

- ❑ Orthogonal Frequency Division Multiplexing
- ❑ Ten 100 kHz channels are better than one 1 MHz Channel  
⇒ Multi-carrier modulation

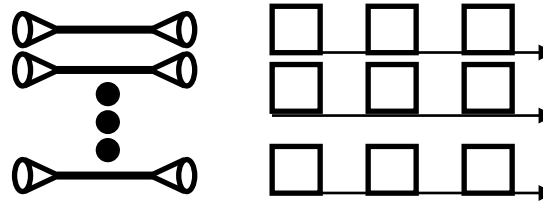
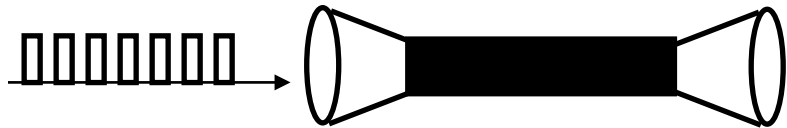

- ❑ The frequency band is divided into 256 or more sub-bands. Orthogonal ⇒ Peak of one at the null of others
- ❑ Each carrier is modulated with a **BPSK** (2bps/Hz), **QPSK** (4 bps/Hz), **16-QAM** (8bps/Hz), **64-QAM** (16 bps/Hz), etc depending on the noise (Frequency selective fading)
- ❑ Used in 802.11a/g, 802.16, Digital Video Broadcast handheld (DVB-H)<sub>ind</sub>
- ❑ Easy to implement using FFT/IFFT

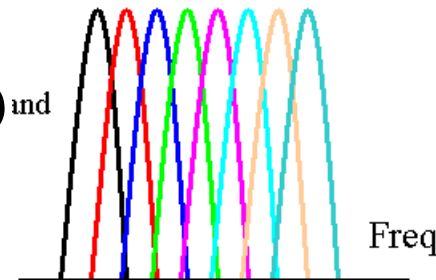

## Student Questions

- ❑ 16-What is FFT? *Fast Fourier Transform*



# HomePlug

- ❑ HomePlug 1.0
- ❑ HomePlug AV
- ❑ HomePlug AV2
- ❑ HomePlug GP
- ❑ HomePlug BPL



## Student Questions

# Connected Home



## Student Questions

# HomePlug AV

- ❑ HomePlug Alliance: Industry consortium for power line communications Disbanded in October 2016.
- ❑ 90% of PLC devices use HomePlug
- ❑ 1.8 MHz to 30 MHz spectrum = 28 MHz  $\Rightarrow$  20 to 200 Mbps
- ❑ Multipath distortion
- ❑ **Orthogonal Frequency Division Multiplexing (OFDM):**  
Using 1155 carriers at 24.414 kHz spacing, 917 are used for the signal. Rest as pilots.
- ❑ **Adaptive bit loading:** Each carrier is modulated based on the noise level and multipath at that frequency.  
2-bits/symbol to 10 bits/symbol.
- ❑ **Tone Maps:** Each receiver keeps a table of signal strengths from each of the other receivers  $\Rightarrow$  n-1 tone maps in a n-device system

## Student Questions

- ❑ What is the structure of the HomePlug AV system?

*It is just the physical layer with management and fault detection.*

---

# HomePlug AV (Cont)

- ❑ **Robust OFDM** (ROBO) mode for highly reliable transmission. The same information is transmitted on 2-5 subcarriers using a low-bit rate modulation
- ❑ Use only a Line-neutral pair (ground is not used)
- ❑ Four-channel access priorities
- ❑ MAC is similar to that of Wi-Fi  
⇒ **Carrier Sense Multiple Access (CSMA)**.
- ❑ All devices part of the same trust domain form an “**AV Logical Network** (AVLN).”
- ❑ All members of the AVLN share a Network Membership Key 128-bit AES.
- ❑ Each AVLN has a **central coordinator (CCo)**

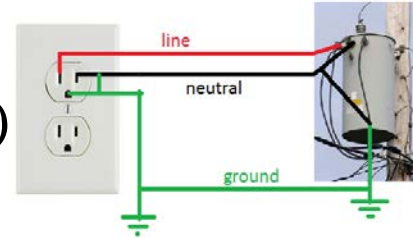

## Student Questions

- ❑ Please can you relate the long best-effort pre-allocation to the committed information rate?

*Guaranteed QoS is relevant in a carrier world. Inside a home, you want to program whatever QoS you need—no CIR.*

- ❑ What categories is HomePlug AV in? Is it an L1 protocol that can run Ethernet?

*Yes. It is an L1 protocol.*

# HomePlug AV (Cont)

- ❑ CCo transmits beacons containing schedule
- ❑ Long best-effort transmissions declare their queues to Cco and use a pre-allocated **persistent shared CSMA** region
- ❑ Short best-effort transmissions use **non-persistent CSMA** regions.
- ❑ Real-time traffic uses periodic time division multiple access (TDMA) allocation in the **contention-free** period
- ❑ Before video transmission, the transmitter tests the channel for achievable throughput. It helps determine the required transmission interval per beacon period

Beacon Region	Persistent Shared CSMA Region	Non-Persistent Local CSMA	Non-Persistent Local CSMA	Persistent Allocation 1	Persistent Allocation n
---------------	-------------------------------	---------------------------	---------------------------	-------------------------	-------------------------

## Student Questions

- ❑ TDMA requires a central clock. How do these devices synchronize with each other?  
*Everyone synchronizes to the beacon.*

# HomePlug AV Security

- ❑ A station can participate in an AVLN with the **Network membership key (NMK)**.  
A station with multiple keys can participate in multiple AVLNs.
- ❑ All devices have a default NMK and so can form the network.  
Users should program the devices to use specific NMK.
- ❑ Once a device has an NMK, it will be given the **network encryption key**, which is used to encrypt the data.
- ❑ If there are multiple networks on the same wire, CCoS coordinate their transmission schedules.

## Student Questions

- ❑ What are the main advantages of OFDM?  
OFDM is the latest modulation. 1G was FDMA. 2G was TDMA, 3G was CDMA, 4G and 5G are OFDMA.
- ❑ Could someone make a fake NMK to cheat the user using other devices connected with AVLN? I am not sure how the AVLN knows the device's identity.

*Authentication is limited to NMK. If you have the key, you can enter. You are then trusted and can declare your identity. This mechanism does not detect insider attacks.*

---

# HomePlug AV2

- ❑ Gigabit networking using home powerline wiring. Peak PHY rate of 1.256 Gbps. 600 Mbps net throughput.
- ❑ Can transmit multiple HD video streams
- ❑ Compatible with HomePlug AV devices on the same wires
- 1. **Additional Spectrum:** 2MHz-86MHz (84 MHz)
- 2. **Multiple-input Multiple-output (MIMO):** transmissions using two wires with a three-wire configuration (Line-Neutral, Line-Ground, Neutral-Ground)
- 3. **Beamforming:** Bit loading for each transmitter
- 4. **Lower overhead:** Shorter packet delimiter and delay acks.
- 5. **Efficient notching:** Of noisy carriers

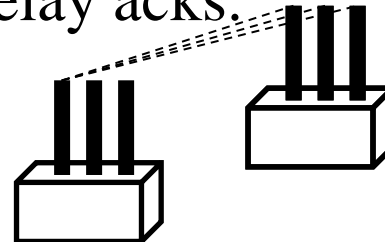

## Student Questions

- ❑ Even considering the preamble, isn't 50% net throughput too low? Isn't this a particular case?

*In wireless, it is pretty standard since there are many bit errors, so there is much redundancy.*

- ❑ Does high-frequency signal bring electromagnetic interference to other communication systems?

*Interference is similar to wireless signals.*

- ❑ I didn't understand how Beamforming could be done in a wired medium since we discussed it in the HomePlug AV context.

*MIMO works by transmitting signals with different phases on different paths and then combining them at the receiver such that the designed signal is enhanced and the noise decreases. Similar to wireless.*

# HomePlug AV2

- ❑ Gigabit networking using home powerline wiring. Peak PHY rate of 1.256 Gbps. 600 Mbps net throughput.
  - ❑ Can transmit multiple HD video streams
  - ❑ Compatible with HomePlug AV devices on the same wires
1. **Additional Spectrum:** 2MHz-86MHz (84 MHz)
  2. **Multiple-input Multiple-output (MIMO):** transmissions using two wires with a three-wire configuration (Line-Neutral, Line-Ground, Neutral-Ground)
  3. **Beamforming:** Bit loading for each transmitter
  4. **Lower overhead:** Shorter packet delimiter and delay acks.
  5. **Efficient notching:** Of noisy carriers

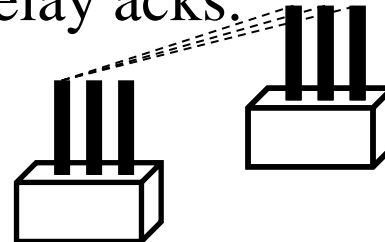

## Student Questions

- ❑ Compared to AV2, Wi-Fi 802.11n also has a throughput of 600Mbps and MIMO. But 802.11n uses 2.4 GHz. What is the reason for using such a higher frequency than AV2?

*Lower frequencies are not available for wireless.*

---



# HomePlug AV2 (Cont)

- Repeating:** Signal is demodulated and re-modulated at intermediate devices
- Better coding:** 12 bps/Hz and aggressive code rates (8/9)
- Power Control:** Manage transmission power to enhance coverage and throughput
- Power Save:** Stations can declare sleep periods. Others transmit only when the destination is awake.

Signal

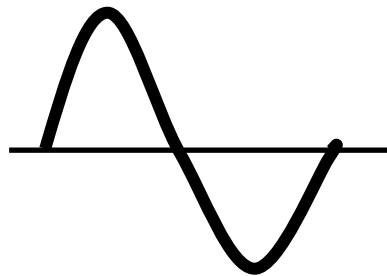

Signal + Noise

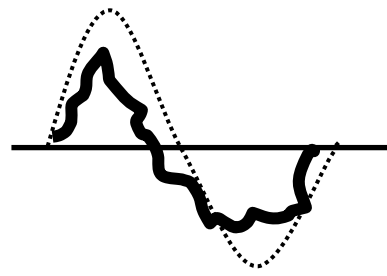

## Student Questions

- How do you decide if something is a noise?

*The signal is modulated on a sine wave. The noise is random.*

- The video sounds like OFDM, beam forming, and MIMO are used in wireless. Are these used on the power lines in this module instead of wirelessly?

*YES. Both use radio frequencies.*

- If the carrier is noisy, can the transmission be understood at all? Or would it cause more burden for the HomePlug device; therefore, it will be slowed down?

*The end device receives a noiseless, well-formed signal.*

- Can you explain the three configurations, please?



- For aggressive code rates, is the additional bit arbitrary?

*Not arbitrary. Everything is based on signal and information theory.*

# HomePlug GreenPHY

- ❑ Designed for **home area network (HAN)** to monitor and control energy-consuming/controlling devices, including electric vehicle charging.
- ❑ Low cost. Low power. Low data rate version of HomePlug AV.

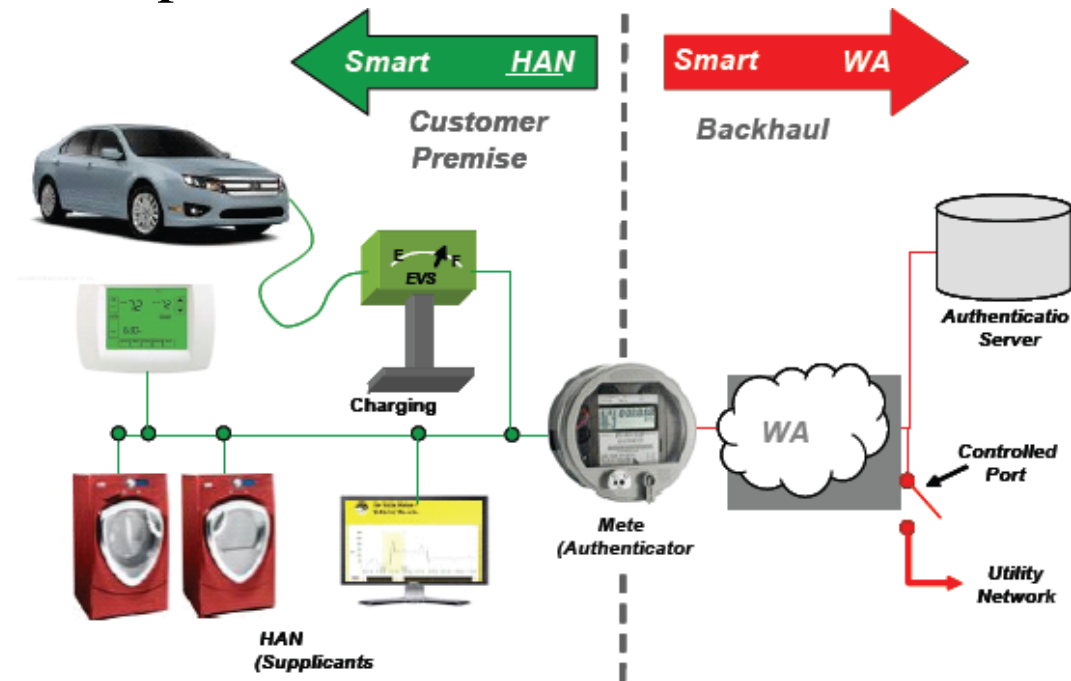

## Student Questions

- ❑ Why don't we send the data via Wi-Fi/LAN?  
*High radio frequency noise environments such as many machines.*
- ❑ The points on this slide appear contradictory. Can you explain how they fit together? The quiz says GreenPHY is for high power.  
*GreenPHY is for "energy-consuming" devices. See the Automobile in the picture.*
- ❑ Except for the control/monitoring of electric vehicle charging, could you please give more examples of other kinds of control/monitoring of energy consumption?  
*Washer, Dryer, Pumps*

# HomePlug GP (Cont)

- ❑ HomePlug GP is a profile of **IEEE 1901-2010** standard for Powerline Networks and is compatible with HomePlug AV and HomePlug AV2.
- ❑ 28 MHz  $\Rightarrow$  256 kbps to 10 Mbps using only one modulation  
No tone maps.
- ❑ Use 75% less power than HomePlug AV.  
75% less bill of materials
- ❑ Devices coordinate their sleep cycle and may sleep for  $2^n$  beacon intervals,  $n=1,\dots,10$
- ❑ HomePlug GP 1.1 adds new power management and features for electric vehicles. Secure billing is possible at a public charging station.

## Student Questions

- ❑ Can you please repeat how you calculated bits per Hertz?  
*Part of the wireless course. It's not required here.*
  - ❑ What do you mean by Beacon interval?  
*CCO sends out a beacon frame every few ms.  
The time between beacons is the beacon interval.*
-

# Convergent Digital Home Network

- ❑ IEEE 1905.1-2013 Convergent Digital Home Network for Heterogeneous Technologies
- ❑ Combined use of Wi-Fi, HomePlug, Ethernet, and Multimedia over Coax (MoCA) in a home

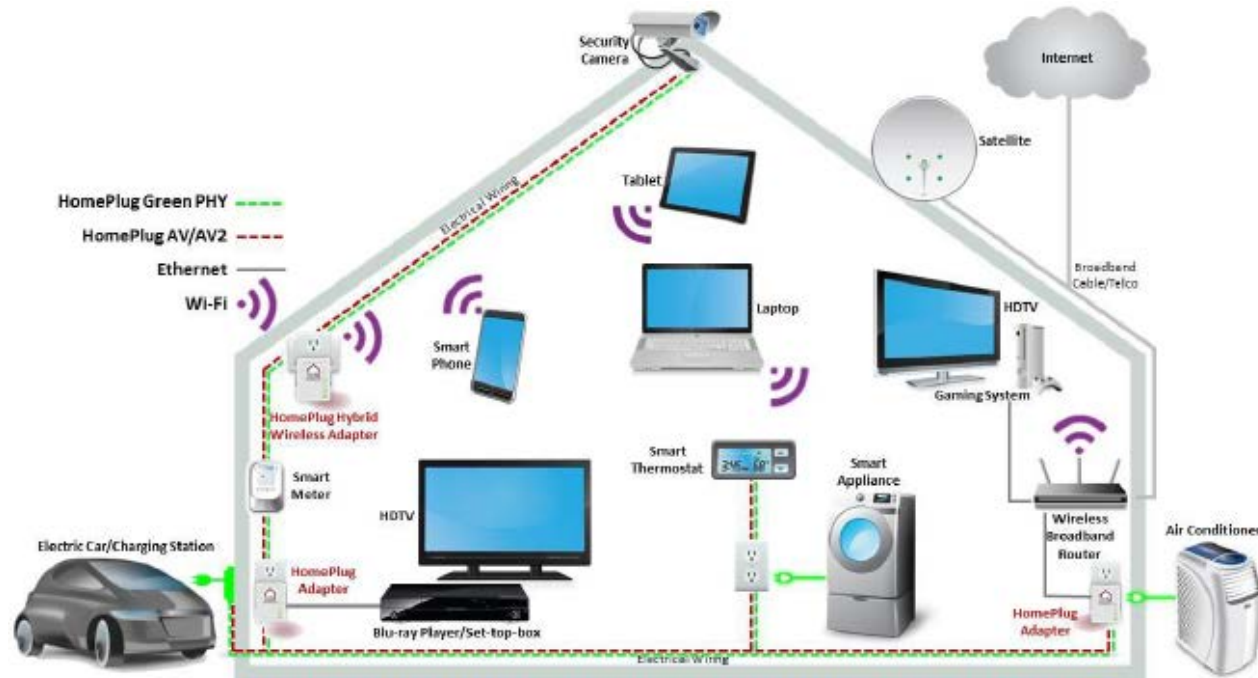

## Student Questions

- ❑ Are all apartments and houses using shielded coaxial cable now? Why can it prevent noise?  
*No. HomePlug works on legacy unshielded wires. There is noise.*

# Convergent Digital Home (Cont)

- ❑ The entire home looks like a single network with automated provisioning, management, and operation
- ❑ Allows a device to aggregate throughput from multiple interfaces
- ❑ A link can be used as a fallback when another link fails
- ❑ An abstraction layer is used to exchange **Control Message Data Unit (CMDU)** among 1905.1 compliant devices
- ❑ No changes to underlying technologies are required.

Network Layer			
1905.1 Abstraction Layer			
802.3	802.11	PLC 1901	MoCA

## Student Questions

- ❑ Is this the only protocol 1905.1 to allow HomePlug devices to connect with other technologies?

*At this time, this is it. However, even this is rarely used so far.*

---

# IEEE 1905.1 Management

- 1905.1 compliant devices speak Abstraction Layer Management Entity (ALME) Protocol

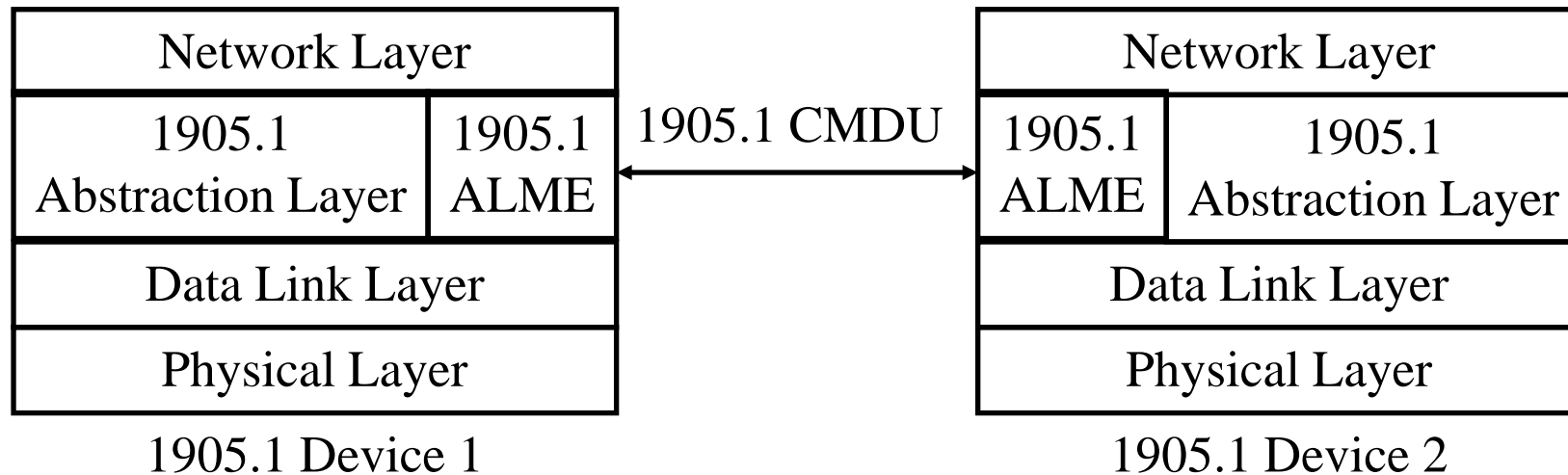

## Student Questions

- Is the ALME L2.5?  
*No, it goes in the management stack. See slide 11.3.*
- In the video, you mentioned that "control management" goes through this entity, and "data" goes through that entity. We couldn't see where you were pointing!  
*Control and management go through ALME and 1905.1, while data goes through the datalink layer.*

# IEEE 1905.1 Management (Cont)

- ❑ ALME has messages for
  - Neighbor discovery,
  - Topology exchange,
  - Topology change notification,
  - Measured traffic statistics exchange,
  - Flow forwarding rules, and
  - Security associations
- ❑ HomePlug AV2 can be used as a backbone for Wi-Fi
- ❑ Existing IEEE 802.1 bridging protocols are used for loop prevention and forwarding

## Student Questions

- ❑ In HomePlug AV, the CCo is responsible for security/keys. Here, you are saying that we need 1905.1 to handle that. Can you please highlight the difference? Does that mean that HomePlug AV2 can't have a CCo?

*CCo is the entity that generates the keys. 1905.1 is the protocol used to exchange security information.*

- ❑ What is loop prevention in HomePlug AV? Is it similar to AV2?

*Yes. Both prevent loops.*

---

# IEEE 1905.1 Security and Configuration

- ❑ Security Setup:
  - **Push Button**: Press buttons on new and existing devices  
The new device gets the keys from the existing device
  - Users can configure a **passphrase/key** in the new device
  - **NFC**: The user touches the new device with an NFC-equipped smartphone, which is an existing member of the network
- ❑ Auto-configuration:
  - New Access Points (APs) can get configuration information from existing APs
- ❑ The certification program for IEEE 1905.1 is called “**nVoy.**”  
Connects disparate networks = Network Diplomat = Network Envoy ⇒ nVoy
- ❑ Qualcomm Atheros products implementing IEEE 1905.1 are called **Hy-Fi** (for Hybrid Fidelity)

## Student Questions



# Netricity

- ❑ Long-range outside-the-home PLC for smart grid applications
- ❑ Certification for IEEE 1901.2 Low Frequency, Narrowband Powerline Communications Standard is called “Netricity”



## Student Questions

- ❑ Since Netricity uses low freq, it doesn't need a repeater to pass through transformers. Is this correct?

*I think so.*

---

# Industrial Ethernet

- ❑ Same as regular Ethernet but with rugged connectors and designed for extended temperature/humidity environment
- ❑ Full duplex links (no CSMA/CD)
- ❑ Optical fibers (electrical interference)
- ❑ Min frame size of 64 bytes may be too big for some applications

## Student Questions

Ref: [http://en.wikipedia.org/wiki/Industrial\\_Ethernet](http://en.wikipedia.org/wiki/Industrial_Ethernet)

Washington University in St. Louis

<http://www.cse.wustl.edu/~jain/cse570-23/>

©2023 Raj Jain

# IEEE 1451

- ❑ Set of smart transducer interfaces for sensors and actuators
- ❑ Transducer electronic data sheets (TEDS) is a memory device that stores transducer id, calibration, correction data, and manufacturer information
- ❑ Allows access to transducer data regardless of wired or wireless connection
- ❑ XML-based  $\Rightarrow$  Allows manufacturers to change the contents

Ref: [http://en.wikipedia.org/wiki/IEEE\\_1451](http://en.wikipedia.org/wiki/IEEE_1451)

Washington University in St. Louis

<http://www.cse.wustl.edu/~jain/cse570-23/>

©2023 Raj Jain

## Student Questions

- ❑ What Layer is 1451?

*Management stack. See slide 11.3.*

---

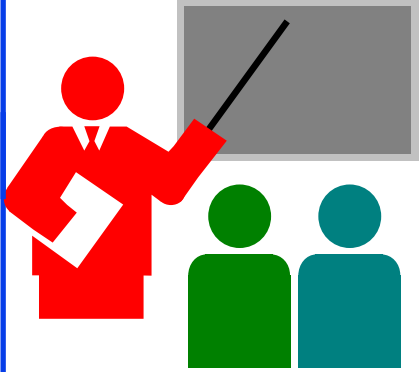

# Summary

1. Several datalink protocols have been proposed for IoT. Among non-wireless protocols, the most common is HomePlug.
2. HomePlug has been extended to provide a higher data rate of up to 600 Mbps by HomePlug AV2 standard and to an energy-saving HomePlug GP.
3. IEEE 1905.1 provides an abstraction layer to hide the details of various datalink layers, such as ZigBee, HomePlug, Wi-Fi, etc...

## Student Questions

# Reading List

- ❑ Tara Salman, Raj Jain, "A Survey of Protocols and Standards for Internet of Things," Advanced Computing and Communications, Vol. 1, No. 1, March 2017,  
[http://www.cse.wustl.edu/~jain/papers/iot\\_accs.htm](http://www.cse.wustl.edu/~jain/papers/iot_accs.htm)
- ❑ HomePlug Alliance, "HomePlug AV White Paper,"  
[https://www.solwise.co.uk/downloads/files/hpav-white-paper\\_050818.pdf](https://www.solwise.co.uk/downloads/files/hpav-white-paper_050818.pdf)
- ❑ HomePlug Alliance, "HomePlug AV2 Technology,"  
<https://content.codico.com/fileadmin/media/download/datasheets/powerline-communication/homeplug-av-av2/homeplug-av2-whitepaper.pdf>
- ❑ HomePlug Alliance, "Home Plug Green PHY The Standard For In-Home Smart Grid Powerline Communications,"  
[https://content.codico.com/fileadmin/media/download/datasheets/powerline-communication/plc-homeplug-green-phy/homeplug\\_green\\_phy\\_whitepaper.pdf](https://content.codico.com/fileadmin/media/download/datasheets/powerline-communication/plc-homeplug-green-phy/homeplug_green_phy_whitepaper.pdf)

## Student Questions

# References

- ❑ H. Chaouchi, "The Internet of Things: Connecting Objects," Wiley, Jun 2010, 288 pp., ISBN: 9781848211407 (Safari Book)
- ❑ H. Zhou, "The Internet of Things in the Cloud: A middleware Perspective," CRC Press, 2013, 366pp., ISBN:9781439892992 (Safari Book)
- ❑ Dave Evans, "The Internet of Things: How the Next Evolution of the Internet Is Changing Everything," Cisco white paper, April 2011,  
[https://www.cisco.com/c/dam/en\\_us/about/ac79/docs/innov/IoT\\_IBSG\\_0411FINAL.pdf](https://www.cisco.com/c/dam/en_us/about/ac79/docs/innov/IoT_IBSG_0411FINAL.pdf)

## Student Questions

# Wikipedia Links

- ❑ [http://en.wikipedia.org/wiki/IEEE\\_1905](http://en.wikipedia.org/wiki/IEEE_1905)
- ❑ [http://en.wikipedia.org/wiki/IEEE\\_1901](http://en.wikipedia.org/wiki/IEEE_1901)
- ❑ [http://en.wikipedia.org/wiki/Broadband\\_over\\_power\\_lines](http://en.wikipedia.org/wiki/Broadband_over_power_lines)
- ❑ [http://en.wikipedia.org/wiki/Power\\_line\\_communication](http://en.wikipedia.org/wiki/Power_line_communication)
- ❑ <http://en.wikipedia.org/wiki/HomePlug>
- ❑ [http://en.wikipedia.org/wiki/Cyber-physical\\_system](http://en.wikipedia.org/wiki/Cyber-physical_system)
- ❑ [http://en.wikipedia.org/wiki/HomePlug\\_Powerline\\_Alliance](http://en.wikipedia.org/wiki/HomePlug_Powerline_Alliance)
- ❑ <http://en.wikipedia.org/wiki/MIMO>
- ❑ <http://en.wikipedia.org/wiki/SCADA>
- ❑ [http://en.wikipedia.org/wiki/Smart\\_grid](http://en.wikipedia.org/wiki/Smart_grid)
- ❑ <http://en.wikipedia.org/wiki/G.hn>
- ❑ [http://en.wikipedia.org/wiki/Orthogonal\\_frequency-division\\_multiplexing](http://en.wikipedia.org/wiki/Orthogonal_frequency-division_multiplexing)
- ❑ [http://en.wikipedia.org/wiki/IEEE\\_Smart\\_Grid](http://en.wikipedia.org/wiki/IEEE_Smart_Grid)
- ❑ <http://en.wikipedia.org/wiki/Fieldbus>
- ❑ [http://en.wikipedia.org/wiki/Industrial\\_Ethernet](http://en.wikipedia.org/wiki/Industrial_Ethernet)
- ❑ [http://en.wikipedia.org/wiki/IEEE\\_1451](http://en.wikipedia.org/wiki/IEEE_1451)

## Student Questions

# Wikipedia Links (Cont)

- ❑ [http://en.wikipedia.org/wiki/List\\_of\\_broadband\\_over\\_power\\_line\\_deployments](http://en.wikipedia.org/wiki/List_of_broadband_over_power_line_deployments)
- ❑ [http://en.wikipedia.org/wiki/Qualcomm\\_Atheros](http://en.wikipedia.org/wiki/Qualcomm_Atheros)
- ❑ <http://en.wikipedia.org/wiki/G.9972>
- ❑ [http://en.wikipedia.org/wiki/Home\\_network](http://en.wikipedia.org/wiki/Home_network)
- ❑ <http://en.wikipedia.org/wiki/SPiDCOM>
- ❑ [http://en.wikipedia.org/wiki/Smart\\_meter](http://en.wikipedia.org/wiki/Smart_meter)
- ❑ [http://en.wikipedia.org/wiki/IEC\\_62196](http://en.wikipedia.org/wiki/IEC_62196)

## Student Questions



# Acronyms

- ❑ 6LowPAN IPv6 over Low Power Wireless Personal Area Network
- ❑ AES Advanced Encryption
- ❑ ALME Abstraction Layer Management Entity
- ❑ AMQP Advanced Queueing Message Protocol
- ❑ AP Access Point
- ❑ AV Audio-Visual
- ❑ AVLN Audio-Visual Logical Network
- ❑ BPL Broadband Over Power Lines
- ❑ BPSK Binary Phase-Shift Keying
- ❑ CCo Central Coordinator
- ❑ CD Collision Detection
- ❑ CEBus Consumer Electronic Bus
- ❑ CMDU Control Message Data Unit
- ❑ CoAP Constrained Application Protocol
- ❑ CP Cyber-Physical

## Student Questions

# Acronyms (Cont)

- ❑ CPS Cyber-Physical Systems
- ❑ CSIA Cyber Security and Information Assurance
- ❑ CSMA Carrier Sense Multiple Access
- ❑ CSMA/CD Carrier Sense Multiple Access with Collision Detection
- ❑ DARPA Defense Advance Research Project Agency
- ❑ DCS Distributed Control Systems
- ❑ DECT Digital Enhanced Cordless Telephony
- ❑ DOE Department of Energy
- ❑ DS2 Design of Systems on Silicon (name of a company)
- ❑ DSL Digital Subscriber Line
- ❑ DVB-H Digital Video Broadcast handheld
- ❑ ECMA European Computer Manufacturers Association
- ❑ FFT Fast Fourier Transform
- ❑ GE General Electric
- ❑ GP Green PHY
- ❑ GreenPHY Green Physical Layer

## Student Questions

# Acronyms (Cont)

- ❑ HAN Home Area Network
- ❑ HCSS High Confidence Software and Systems
- ❑ HD High Definition
- ❑ HDLC High-Level Datalink Control
- ❑ HEC High-End Computing
- ❑ HP HomePlug
- ❑ HPAV HomePlug Audio-Visual
- ❑ ID Identifier
- ❑ IEC International Electro-telecommunications Commission
- ❑ IEEE Institution of Electrical and Electronic Engineers
- ❑ IFFT Inverse Fast Fourier Transform
- ❑ IM Information Management
- ❑ IoT Internet of Things
- ❑ IP Internet Protocol
- ❑ IPv6 Internet Protocol V6
- ❑ ISO International Standards Organization

## Student Questions

# Acronyms (Cont)

- ❑ IT Information Technology
- ❑ kHz Kilo Hertz
- ❑ LonWorks Local Operating Network
- ❑ LSN Large Scale Networking
- ❑ MAC Media Access Control
- ❑ MHz Mega Hertz
- ❑ MIMO Multiple-input Multiple-output
- ❑ MoCA Multimedia over Coax
- ❑ MQ Multi-Queue
- ❑ MQTT MQ Telemetry Transport
- ❑ NASA National Aeronautical and Space Administration
- ❑ NFC Near Field Communication
- ❑ NIH National Institute of Health
- ❑ NITRD Networking and Info Technology Res and Development
- ❑ NMK Network Membership Key
- ❑ NSF National Science Foundation

## Student Questions

# Acronyms (Cont)

- ❑ OAuth Open Standard for Authorization
- ❑ OFDM Orthogonal Frequency Division Multiplexing
- ❑ ONR Office of Naval Research
- ❑ PHY Physical Layer
- ❑ PLC Power Line Communication
- ❑ PROFIBUS Process Field Bus
- ❑ QAM Quadrature Amplitude Modulation
- ❑ QPSK Quadrature Phase Shift Keying
- ❑ RF Radio Frequency
- ❑ RFID Radio Frequency Identification
- ❑ RPL Routing Protocol for Low Power and Lossy Networks
- ❑ SCADA Supervisory Control and Data Acquisition
- ❑ SDP Software Design and Productivity
- ❑ SPiDCOM Name of a company
- ❑ TDMA Time division multiple access
- ❑ TEDS Transducer electronic data sheets

## Student Questions

# Acronyms (Cont)

- ❑ US United States
- ❑ Wi-Fi Wireless Fidelity
- ❑ WorldFIP Factory Instrumentation Protocol
- ❑ XML Extensible Markup Language

## Student Questions

**Scan This to Download These Slides**



Raj Jain

<http://rajjain.com>

[http://www.cse.wustl.edu/~jain/cse570-21/m\\_11dpi.htm](http://www.cse.wustl.edu/~jain/cse570-21/m_11dpi.htm)

**Student Questions**

# Related Modules



CSE567M: Computer Systems Analysis (Spring 2013),

[https://www.youtube.com/playlist?list=PLjGG94etKypJEKjNAa1n\\_1X0bWWNyZcof](https://www.youtube.com/playlist?list=PLjGG94etKypJEKjNAa1n_1X0bWWNyZcof)

CSE473S: Introduction to Computer Networks (Fall 2011),

[https://www.youtube.com/playlist?list=PLjGG94etKypJWOSPMh8Azcg5e\\_10TiDw](https://www.youtube.com/playlist?list=PLjGG94etKypJWOSPMh8Azcg5e_10TiDw)



Wireless and Mobile Networking (Spring 2016),

[https://www.youtube.com/playlist?list=PLjGG94etKypKeb0nzyN9tSs\\_HCd5c4wXF](https://www.youtube.com/playlist?list=PLjGG94etKypKeb0nzyN9tSs_HCd5c4wXF)

CSE571S: Network Security (Fall 2011),

<https://www.youtube.com/playlist?list=PLjGG94etKypKvzfVtutHcPFJXumyyg93u>



Video Podcasts of Prof. Raj Jain's Lectures,

<https://www.youtube.com/channel/UCN4-5wzNP9-ruOzQMs-8NUw>

## Student Questions