

Carrier Ethernet



Raj Jain

Washington University in Saint Louis

Saint Louis, MO 63130

Jain@cse.wustl.edu

These slides and audio/video recordings of this class lecture are at:

<http://www.cse.wustl.edu/~jain/cse570-21/>

Student Questions



1. Enterprise vs Carrier Ethernet
2. UNI vs Peer-to-Peer Signaling
3. Metro Ethernet
4. Ethernet Provider Bridge (PB)
5. Provider Backbone Network (PBB)
6. Connection Oriented Ethernet

Note: Although these technologies were originally developed for carriers, they are now used inside multi-tenant data centers (clouds)

Student Questions

Enterprise vs. Carrier Ethernet

| Enterprise | Carrier |
|--|--|
| <input type="checkbox"/> Distance: up to 2km | <input type="checkbox"/> Up to 100 km |
| <input type="checkbox"/> Scale: <ul style="list-style-type: none">➤ Few K MAC addresses➤ 4096 VLANs | <input type="checkbox"/> Millions of MAC Addresses <input type="checkbox"/> Millions of VLANs Q-in-Q |
| <input type="checkbox"/> Protection: Spanning tree | <input type="checkbox"/> Shortest Path Routing |
| <input type="checkbox"/> Path determined by spanning tree | <input type="checkbox"/> Traffic engineered path |
| <input type="checkbox"/> Simple service | <input type="checkbox"/> SLA |
| <input type="checkbox"/> Priority \Rightarrow Aggregate QoS | <input type="checkbox"/> Need per-flow QoS |
| <input type="checkbox"/> No performance/Error monitoring (OAM) | <input type="checkbox"/> Need performance/BER |

Student Questions

Carriers vs. Enterprise

We need to exchange topology for optimal routing.

Sorry, We can't tell you anything about our internal network.



Student Questions

Network Hierarchy

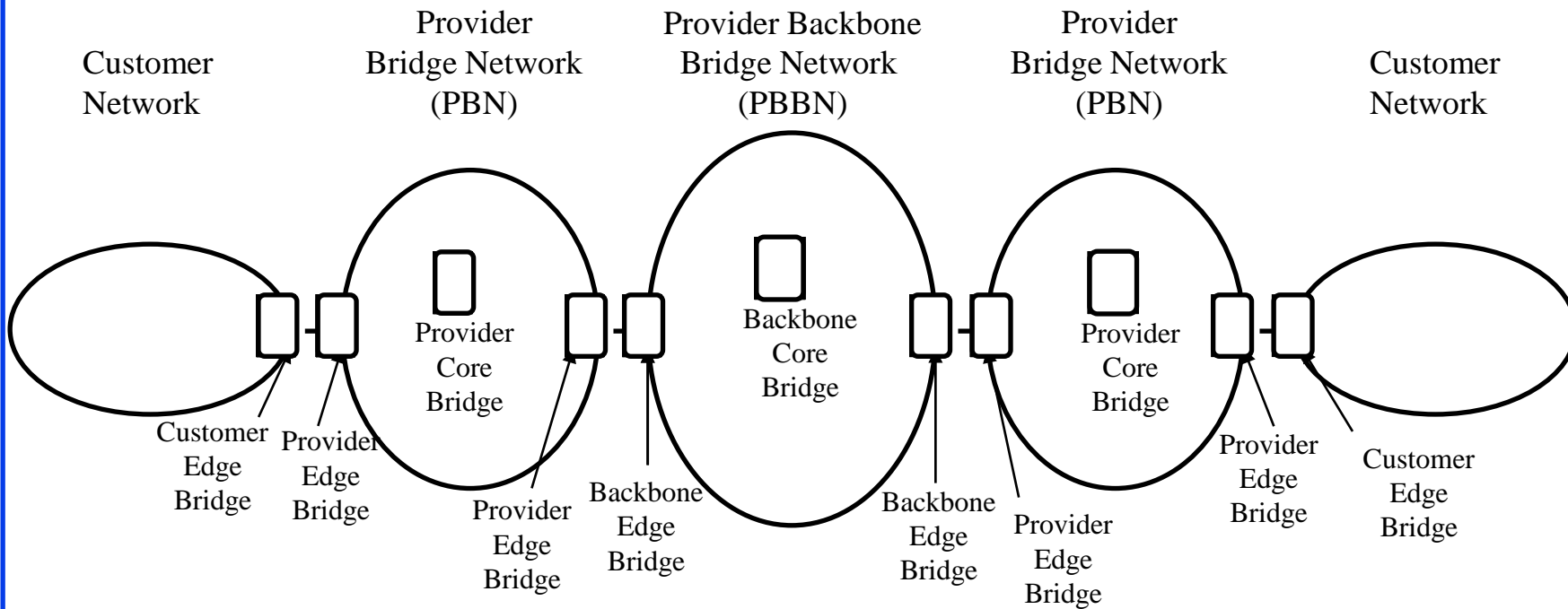

Student Questions

Issue: UNI vs Peer-to-Peer Signaling

- ❑ Two Business Models:
 - Carrier: Overlay or cloud
 - ❑ Network is a black-box
 - ❑ User-to-network interface (UNI)
 - Enterprise: Peer-to-Peer
 - ❑ Complete exchange of information

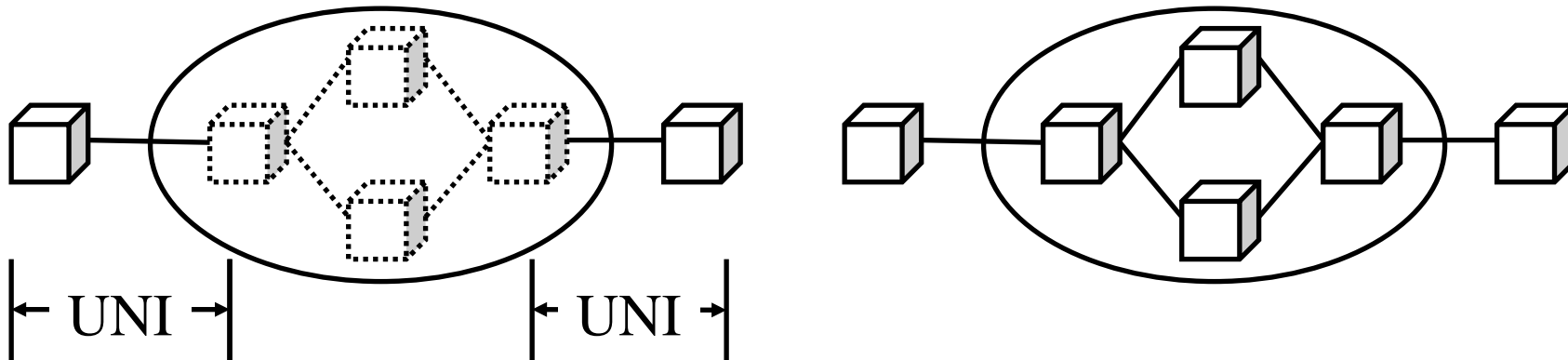

Student Questions

UNI vs. ENNI

❑ User to Network Interface (UNI):

- Separates responsibilities between the user and the provider. (Troubleshooting, failures etc).
- Like the wired phone box outside your home.
- Only one customer's traffic.

❑ External Network to Network Interface (ENNI):

- Separates responsibilities between two providers.
- Many customer's traffic passes through an ENNI
- Tier 2 *operators* sell services to Tier 3 service providers.



Ref: Fujitsu, "Carrier Ethernet Essentials," <http://www.fujitsu.com/downloads/TEL/fnc/whitepapers/CarrierEthernetEssentials.pdf>

Washington University in St. Louis

<http://www.cse.wustl.edu/~jain/cse570-21/>

©2021 Raj Jain

Student Questions

Operator Virtual Connection (OVC)

- ❑ Between UNI and ENNI or between two ENNIs.
- ❑ For wholesale service providers
- ❑ Two types: Point-to-Point and Multipoint-to-Multipoint
- ❑ Untagged or single tagged frames at NNI. Q-in-Q at ENNI
- ❑ UNIs may be 10 to 100 Mbps. ENNIs at 1 to 10 Gbps.

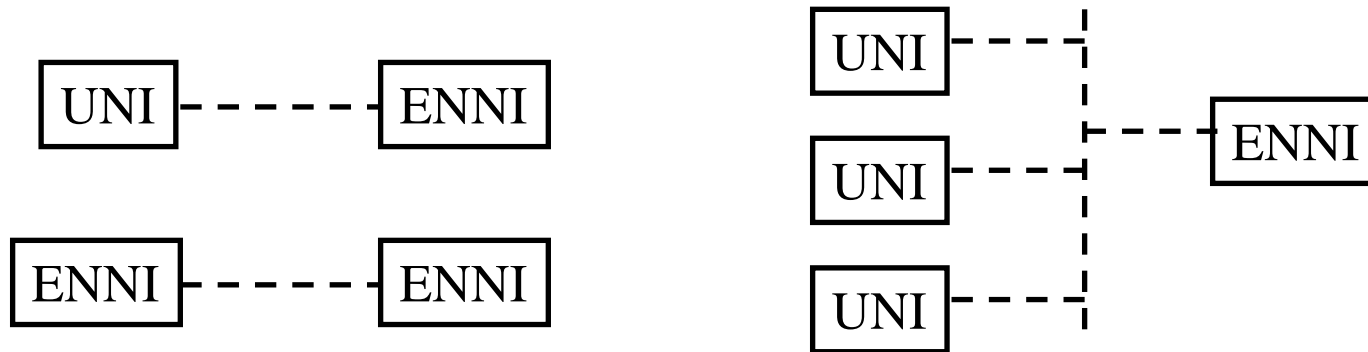

Student Questions

Metro Access Ethernet Private Line

□ Access Ethernet Private Line (Access-EPL):

- Port-based service for Internet access
Like the service at your home.
- Ends at your access provider, where many other Access-EPLs may end
- Access provider has only one interface
Shared by many Access-EPLs \Rightarrow Different from p2p EPL.

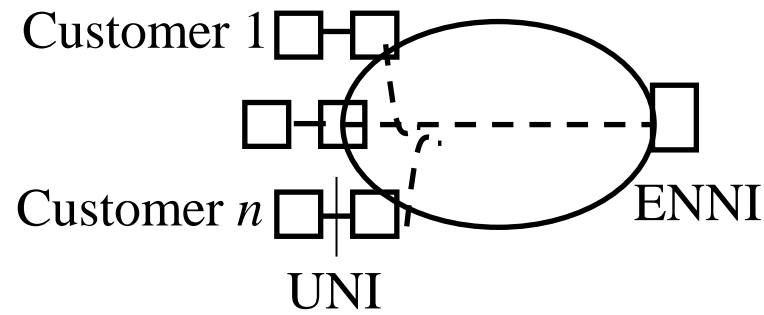

E-Access

Student Questions

End-to-End Metro Ethernet Connection

- An EC may go through multiple service providers
⇒ Multiple OVCs can be concatenated to create an EC

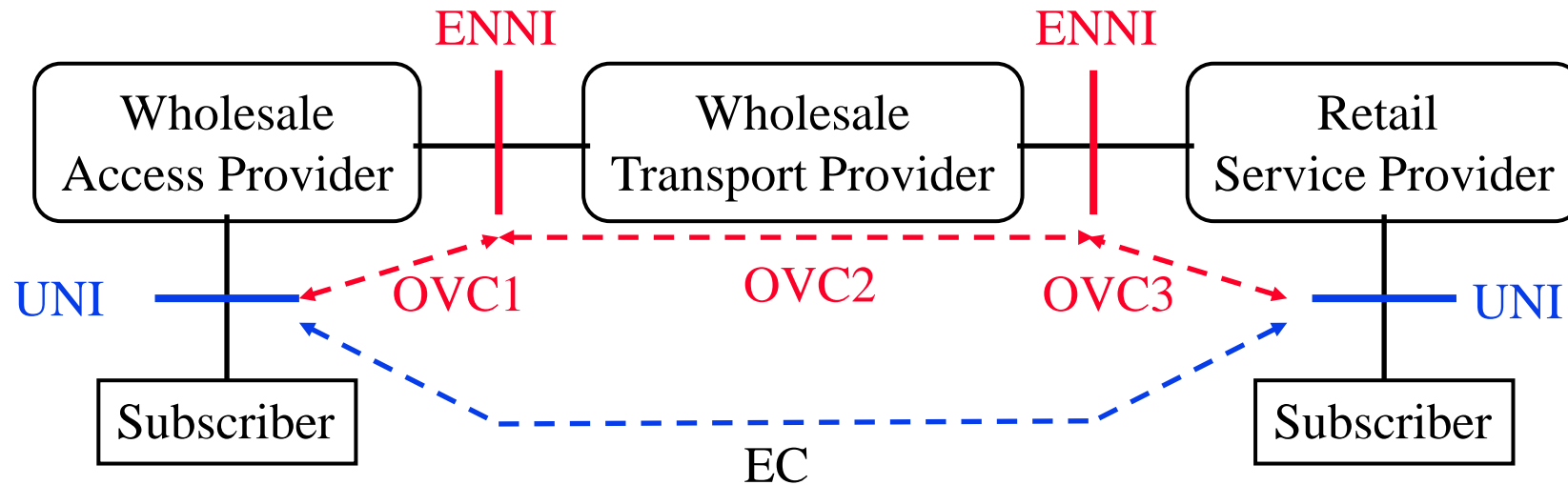

Student Questions

Ethernet Virtual Connections (EVCs)

- ❑ **Port-based ECs:** Forwarding not based on VLANs.
Frames delivered to remote UNI/ENNI for P2P or
Based on destination address for P2MP
- ❑ **VLAN-based ECs:** Forwarding based on VLAN tag.
 - ⇒ Multiple Virtual UNIs
 - ⇒ Ethernet *Virtual* Connection (*EVC*)
 - More cost-effective for Enterprise customers
- ❑ Types of EVCs:
 1. Ethernet Virtual Private Line (EVPL)
 2. Ethernet Virtual Private Tree (EVP-Tree)
 3. Ethernet Virtual Private LAN (EVPLAN)
 4. Access Ethernet Virtual Private Line (Access EVPL)
- ❑ Note: Service providers always share an ENNI for multiple connections ⇒ OVCs are always virtual

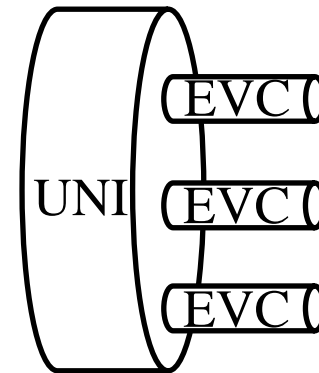

Student Questions

Metro Ethernet Service Attributes

- ❑ Bandwidth Profiles: Limits on data rates
 - Ingress Profile: Incoming data rate
 - Egress Profile: Outgoing data rate
- ❑ Per UNI, Per EVC or OVC, or Per EVC/OVC per Class of Service (CoS)
- ❑ CoS is indicated by the 3-bits in the priority field or 4-bit Differentiated Services Code Point (DSCP)
- ❑ Rate specified by 5 parameters
 1. Committed Information Rate (CIR)
 2. Committed Burst Size (CBS)
 3. *Excess* Information rate (EIR)
 4. Excess Burst Size (EBS)
 5. Color Mode (CM): Customer does/does not mark drop eligibility indicator (DEI)

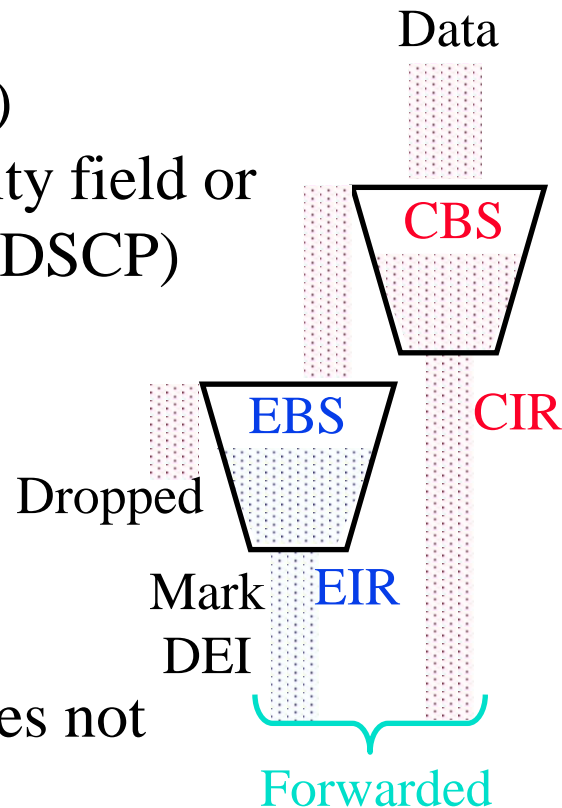

Student Questions

Example

- ❑ A user with CIR=10 Mbps, CBS=2 MB, EIR=2 Mbps, EBS=1MB, sends a 10 MB file at 20 Mbps.
What percent of packets will be dropped?
What percent will be marked?
- ❑ CBS = 2 MB = 16 Mb, EBS = 1 MB = 8 Mb,
File size = 80 Mb
- ❑ File time = 80 Mb/20 Mbps = 4 s
- ❑ 1st Bucket fill rate = 20-10 = 10 Mbps,
1st Bucket fill time = 16/10 = 1.6s
Total output from 1st bucket = 4*10 Mbps + 16 Mb
= 56 Mb (committed) = 70%
- ❑ 1st Bucket Overflow time = 4-1.6 = 2.4s
1st bucket Overflow amount = 2.4 s*(20-10) Mbps
= 24 Mb
- ❑ 2nd bucket fill Rate = 10-2 = 8 Mbps
2nd bucket fill time = Size/Rate = 8 Mb/8 Mbps = 1 s
Total output from 2nd bucket = 0*1.6 + 2*(4 - 1.6) + 8
= 12.8 Mb (Marked) = 16%
- ❑ 2nd Bucket overflow time = 4 - 1.6 - 1 = 1.4s
2nd bucket overflow amount = (10-2)*1.4 = 11.2 Mb (Dropped) = 14%
- ❑ Check: Total = 56+12.8+11.2 = 80 Mb

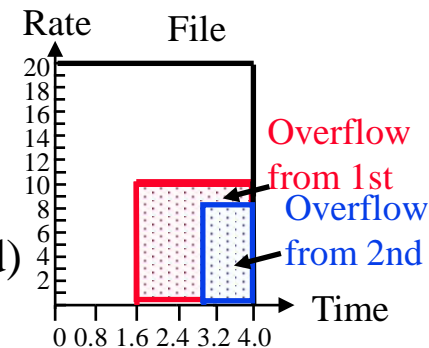
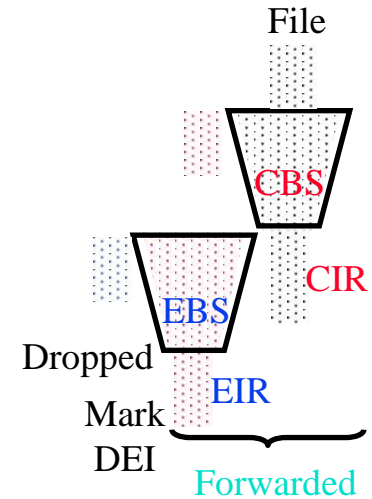

Student Questions

Homework 6

- A user with CIR=25 Mbps, CBS=2 MB, EIR=2 Mbps, EBS=1MB, sends a 15 MB file at 30 Mbps.
What percent of packets will be dropped?
What percent will be marked?

Student Questions

Metro Ethernet OAM

- ❑ Operation, Administration and Maintenance (OAM)
- ❑ Defined in IEEE 802.1ag, IEEE 802.1ah, and ITU Y.1731
- ❑ Maintenance End Points (MEPs)
- ❑ Maintenance Intermediate Points (MIPs)
- ❑ Maintenance Entity Group (MEG): Level of Administration

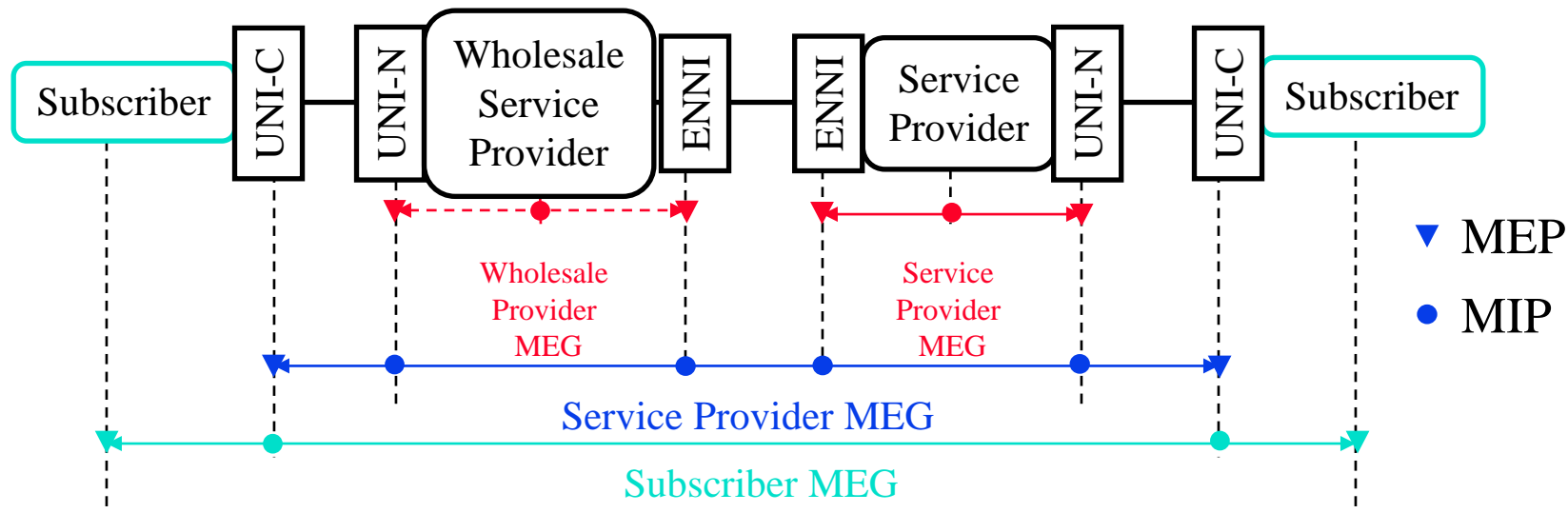

Student Questions

Metro Ethernet OAM (Cont)

- ❑ Performance Monitoring: Measure throughput and latency
- ❑ Connectivity Fault Management: Monitor downtime
 - Service Fault Management
 - Link Fault Management

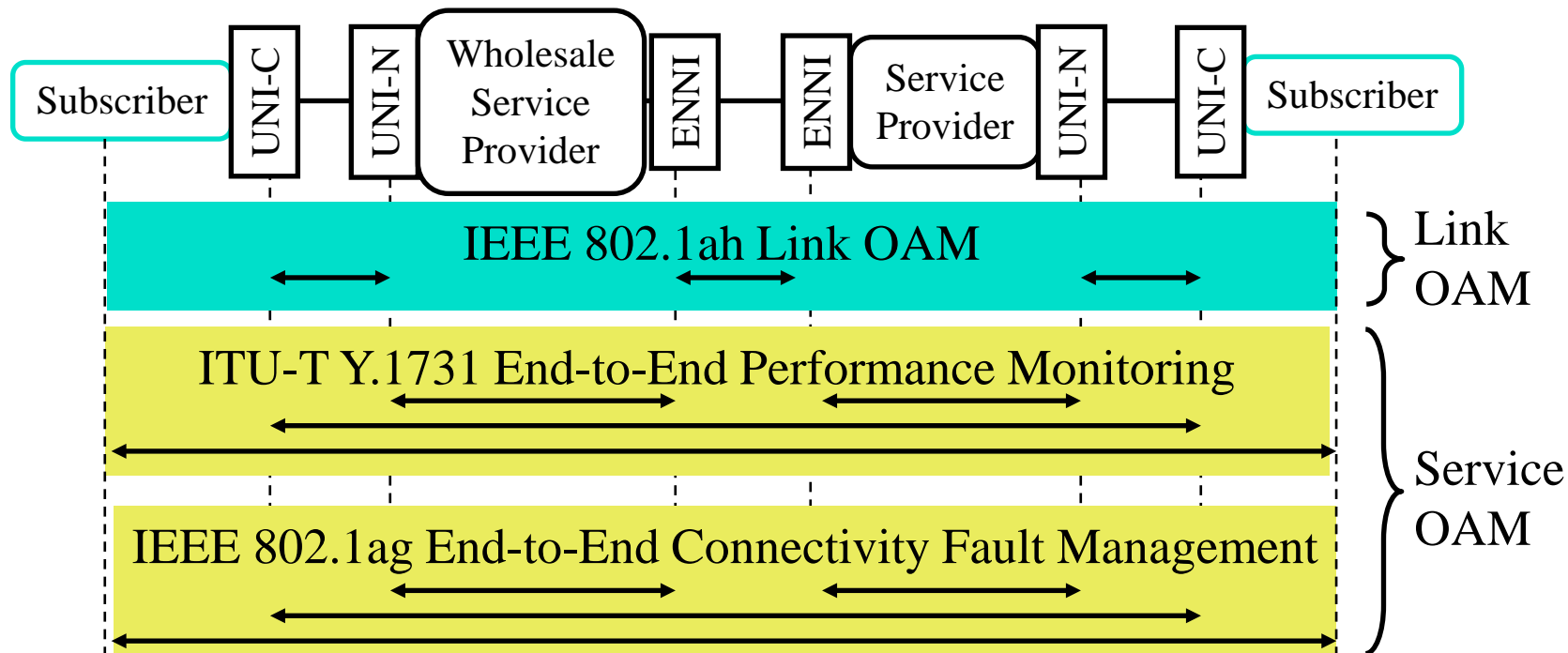

Student Questions

Metro Ethernet OAM Messages

- ❑ Continuity Check Message (CCM) in both directions (Similar to IP Ping)
- ❑ Link Trace Message (LTM): Locates fault. Link Trace Response (LTR) is returned by each end point and intermediate point (similar to IP trace route)
- ❑ Fault, Configuration, Accounting, Performance, Security (FCAPS)

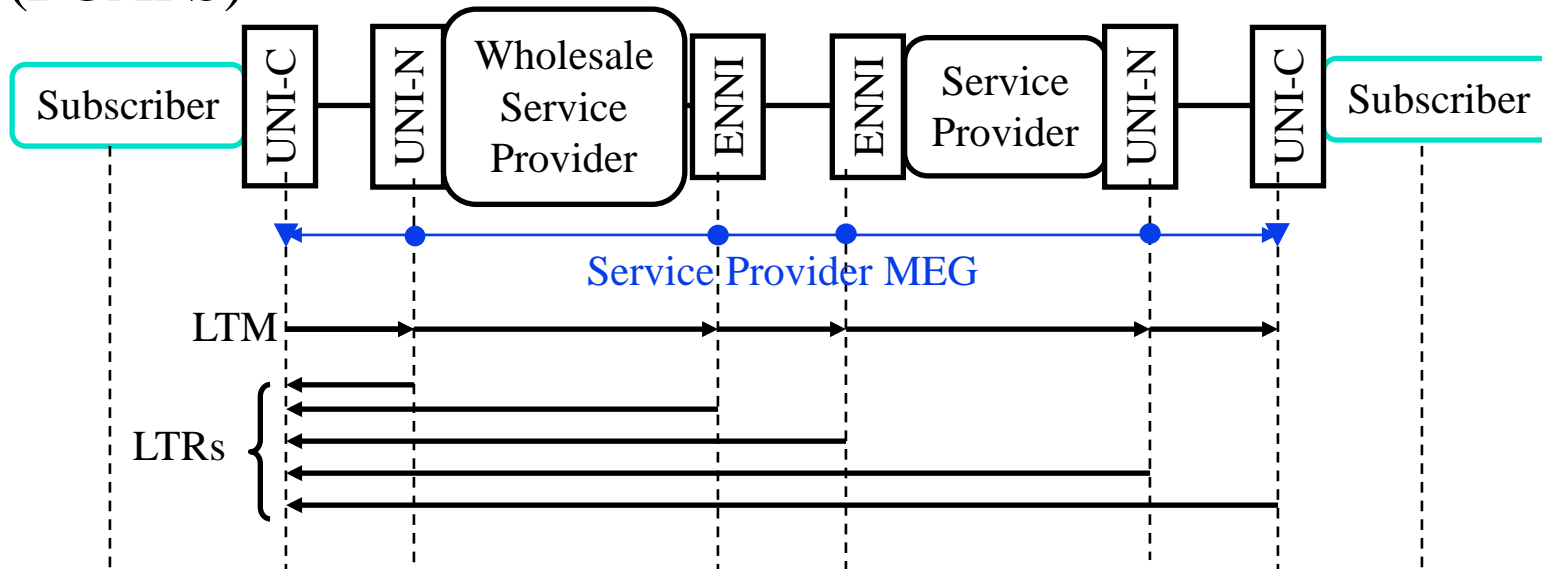

Student Questions

Metro Ethernet Use Cases

1. Head office to Satellite offices and/or Internet

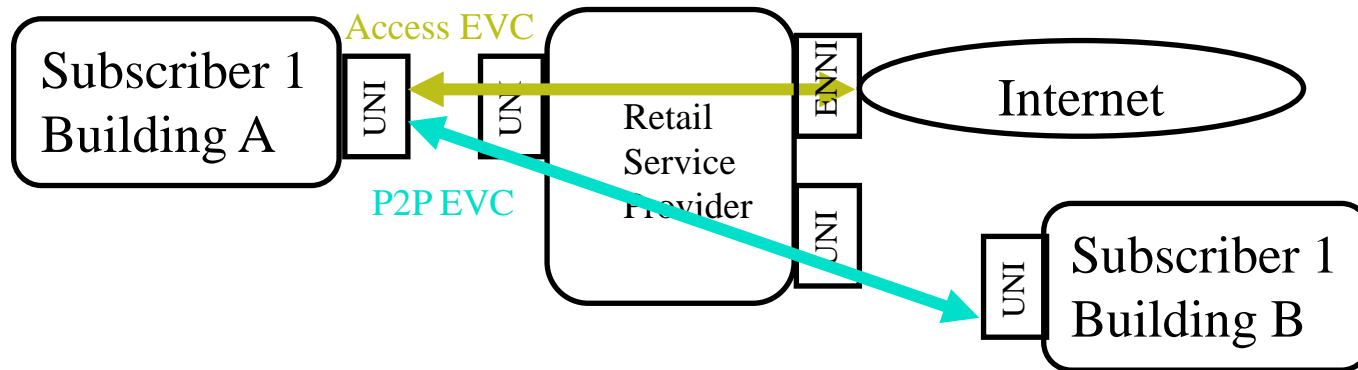

2. Customers to Cloud Service Provider

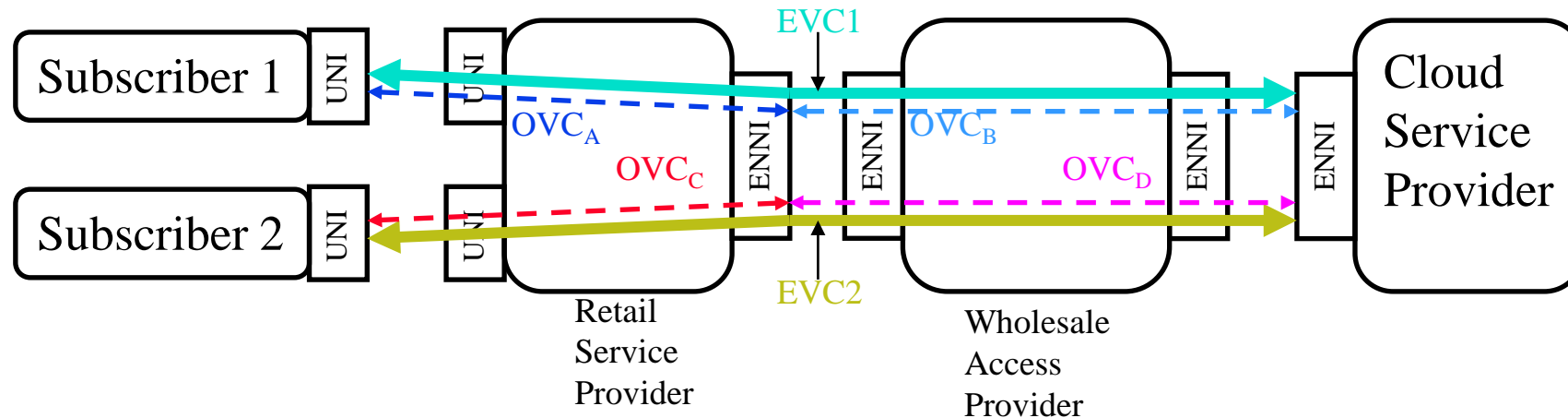

Student Questions

Ethernet Provider Bridge (PB)

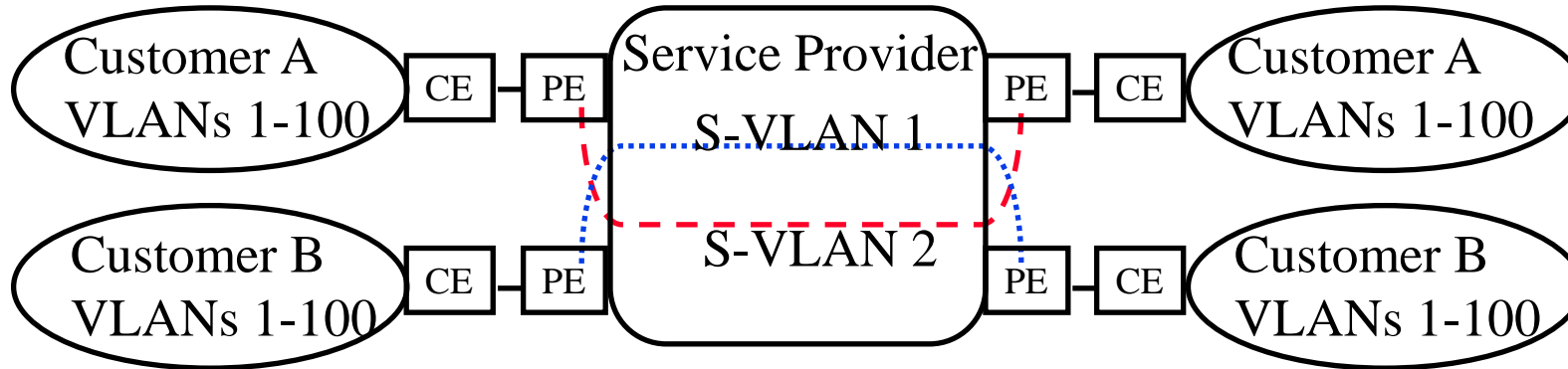

- ❑ IEEE 802.1ad-2005 incorporated in IEEE 802.1Q-2011
- ❑ Problem: Multiple customers may have the same VLAN ID. How to keep them separate?
- ❑ Solutions:
 1. VLAN translation: Change customer VLANs to provider VLANs and back
 2. VLAN Encapsulation: Encapsulate customer frames

Student Questions

Provider Bridge (Cont)

- ❑ Q-in-Q Encapsulation: Provider inserts a service VLAN tag
VLAN translation Changes VLANs using a table
- ❑ Allows 4K customers to be serviced. Total 16M VLANs
- ❑ 8 Traffic Classes using Differentiated Services Code Points (DSCP) for Assured Forwarding

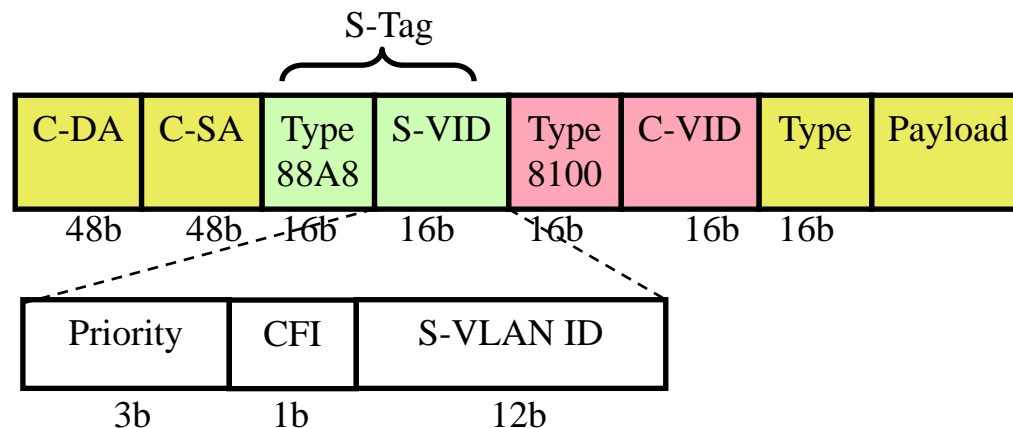

Student Questions

Provider Backbone Network (PBB)

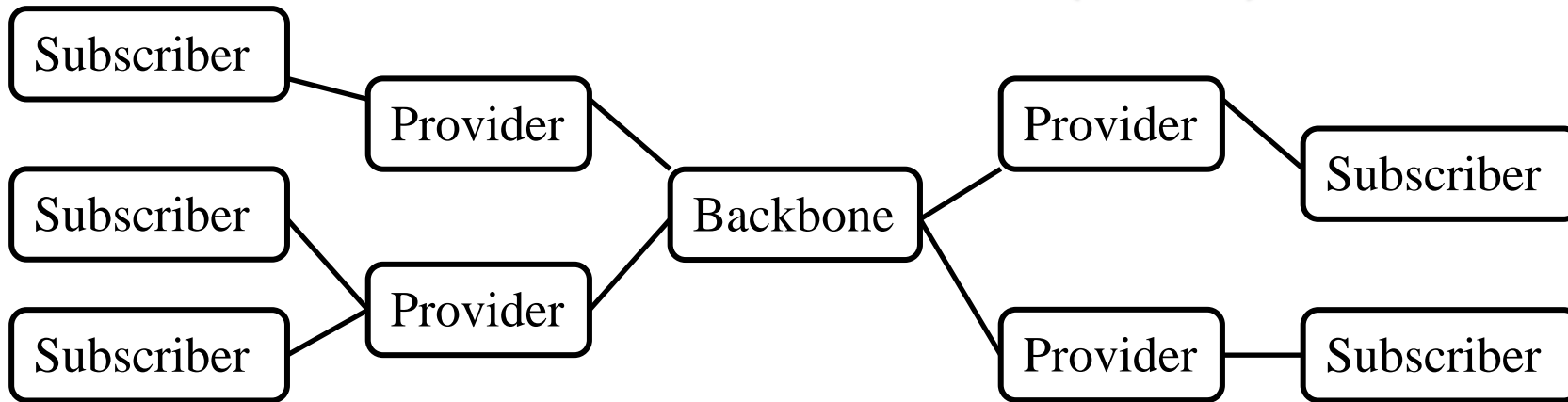

- ❑ Problem: Number of MAC addresses passing through backbone bridges is too large for all core bridge to remember
Broadcast and flooded (unknown address) frames give unwanted traffic and security issues
- ❑ Solution: IEEE 802.1ah-2008 incorporated in 802.1Q-2011
- ❑ Add new source/destination MAC addresses pointing to ingress backbone bridge and egress backbone bridge
⇒ Core bridges only know edge bridge addresses

Student Questions

MAC-in-MAC Frame Format

- ❑ Backbone edge bridges (BEB) forward to other BEB's and learn customer MAC addresses
⇒ Backbone *core* bridges (BCB) do not learn customer MACs
- ❑ B-DA = Destination backbone bridge address
Determined by Customer Destination Address
- ❑ Backbone VLANs delimit the broadcast domains in the backbone

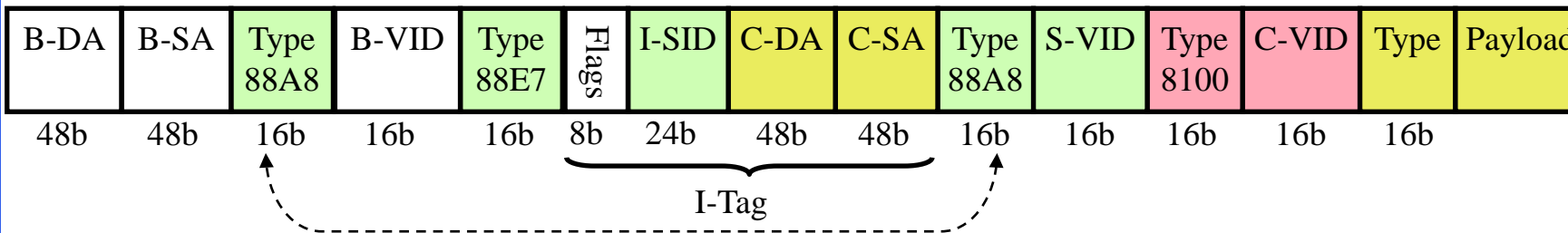
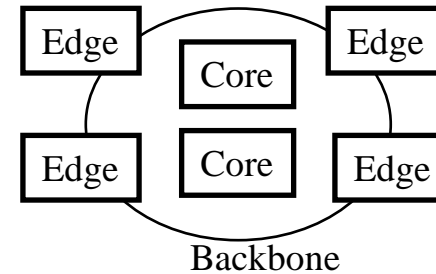

- ❑ Core switches forward based on Backbone Destination Bridge Address and Backbone-VLAN ID (60 bits)
Similar to 802.1ad Q-in-Q. Therefore, same EtherType.

Student Questions

PBB Service Instance

- ❑ 24-bit Service instance ID (I-SID) indicates a specific flow
 - All frames on a specific port, or
 - All frames on a specific port with a specific *service* VLAN, or
 - All frames on a specific port with a specific service VLAN and a specific *customer* VLAN

| SID | Definition | B-VLAN |
|-----|-------------------------------|--------|
| 1 | Port 1 | 1 |
| 20 | Port 2, S-VLAN=10 | 3 |
| 33 | Port 2, S-VLAN=20 | 6 |
| 401 | Port 2, S-VLAN=30, C-VLAN=100 | 4 |
| 502 | Port 3, S-VLAN=40, C-VLAN=200 | 4 |

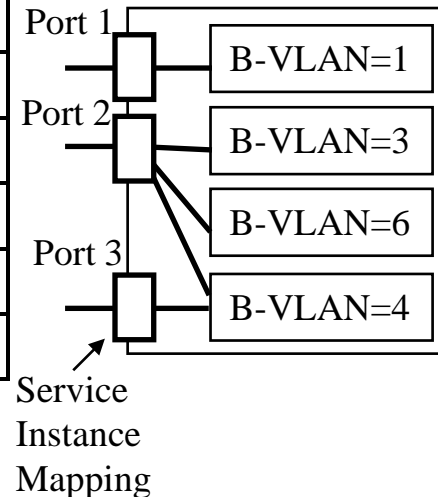

Student Questions

MAC-in-MAC (Cont)

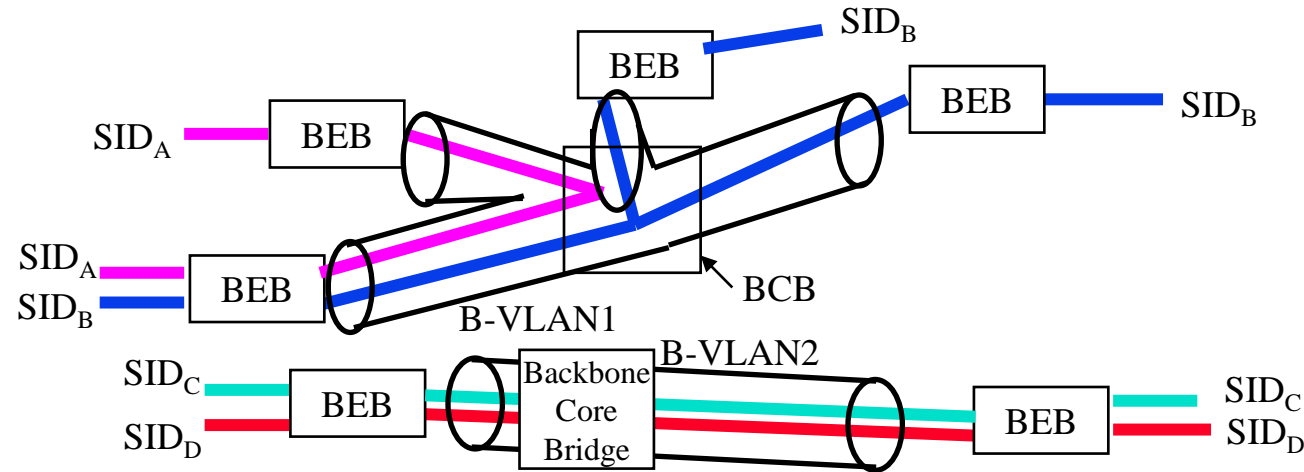

- ❑ Each Backbone VLANs (B-VLAN) can carry multiple services
- ❑ 24-bit SID $\Rightarrow 2^{24}$ Service Instances in the backbone
- ❑ I-Tag format: I-Tag not looked at in the core.
Includes C-DA+C-SA.
UCA=1 \Rightarrow Use customer addresses (used in CFM in the Edge)

| Priority Code Point (I-PCP) | Drop Eligibility Indicator (I-DEI) | Use Customer Address (UCA) | Reserved 1 | Reserved 2 | Service Instance ID (I-SID) | Customer Destination Address (C-DA) | Customer Source Address (C-SA) |
|-----------------------------|------------------------------------|----------------------------|------------|------------|-----------------------------|-------------------------------------|--------------------------------|
| 3b | 1b | 1b | 1b | 2b | 24b | 48b | 48b |

Student Questions

Connection Oriented Ethernet

- ❑ Connectionless: Path determined at forwarding
⇒ Varying QoS
- ❑ Connection Oriented: Path determined at provisioning
 - Path provisioned by management ⇒ Deterministic QoS
 - ❑ No spanning tree, No MAC address learning,
 - ❑ Frames forwarded based on VLAN Ids and Backbone bridges addresses
 - ❑ Path not determined by customer MAC addresses and other customer fields ⇒ More Secure
 - Reserved bandwidth per EVC
 - Pre-provisioned Protection path ⇒ Better availability

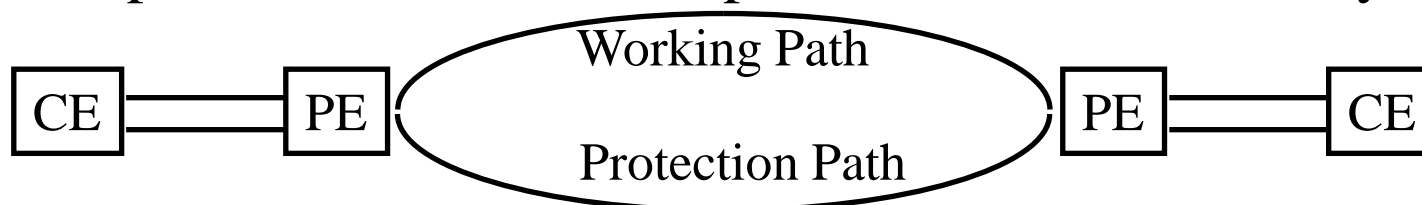

Student Questions

VLAN Cross-Connect

- ❑ Cross-connect \Rightarrow Circuit oriented
- ❑ Connection Oriented Ethernet with Q-in-Q
- ❑ Forward frames based on VLAN ID and Input port
 \Rightarrow No MAC Learning

| Input Port | VLAN ID | Output Port |
|------------|---------|-------------|
| 1 | 200 | 7 |
| 2 | 201 | 5 |
| 3 | 20 | 5 |
| 3 | 21 | 6 |
| 4 | 100 | 7 |
| 4 | 101 | 8 |

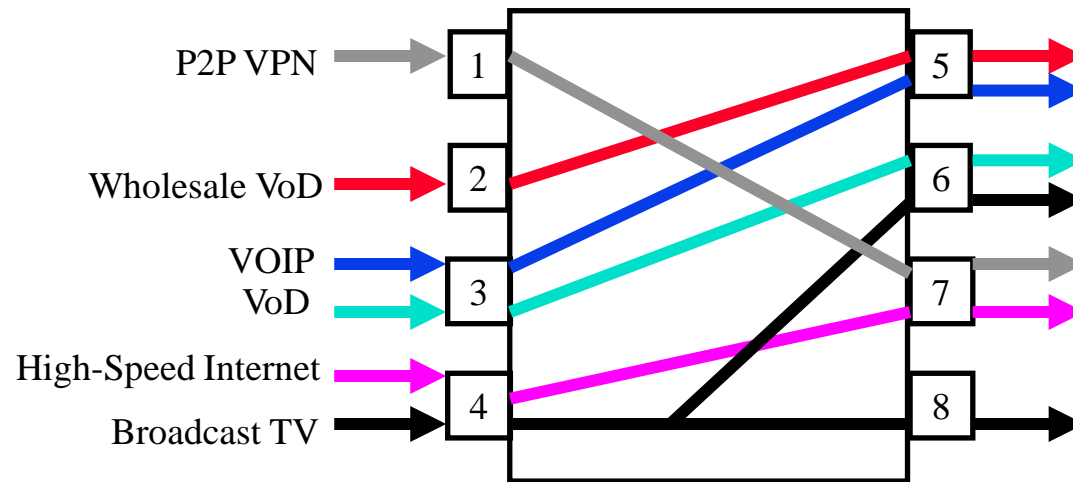

Student Questions

PBB-TE

- ❑ Provider Backbone Bridges with Traffic Engineering (PBB-TE)
- ❑ IEEE 802.1Qay-2009 incorporated in 802.1Q-2011
- ❑ Provides connection oriented P2P (*E-Line*) Ethernet service
- ❑ For PBB-TE traffic VLANs:
 - Turn off MAC learning
 - Discard frames with unknown address and broadcasts.
⇒ No flooding
 - Disable Spanning Tree Protocol.
 - Add protection path switching for each direction of the trunk
- ❑ Switch forwarding tables are administratively populated using management
- ❑ Same frame format as with MAC-in-MAC. No change.

Student Questions

PBB-TE QoS

- ❑ Guarantees QoS \Rightarrow No need for MPLS or SONET/SDH
- ❑ UNI traffic is classified by Port, Service VLAN ID, Customer VLAN ID, priority, Unicast/Multicast
- ❑ UNI ports are *policed* \Rightarrow Excess traffic is dropped
No policing at NNI ports. Only remarking, if necessary.
- ❑ Traffic may be marked and remarked at both UNI and NNI

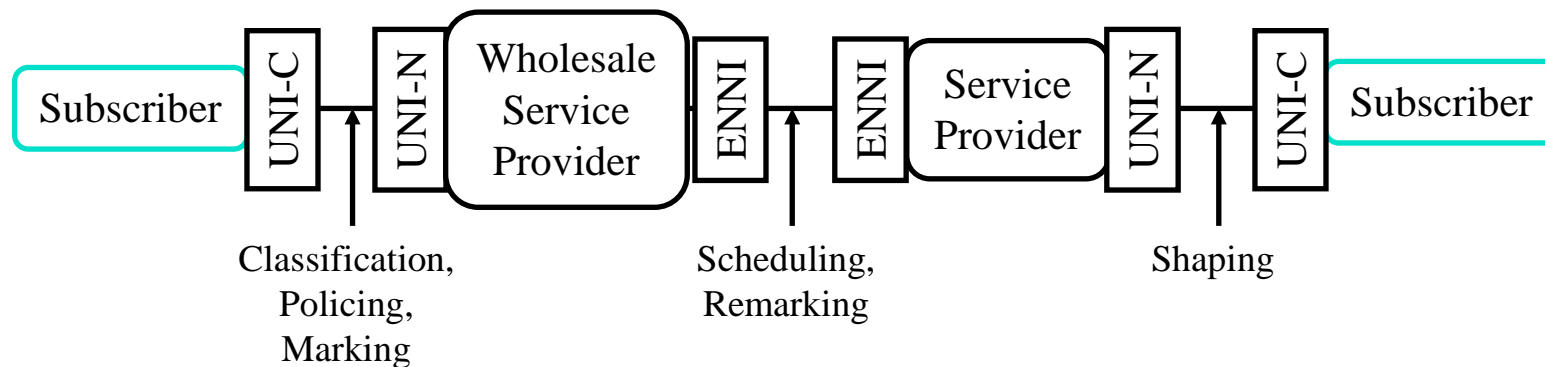

Student Questions

Ethernet Tagged Frame Format Evolution

- Original Ethernet

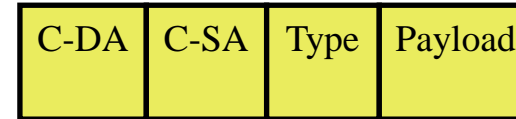

- IEEE 802.1Q VLAN

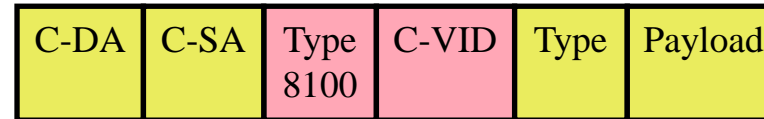

- IEEE 802.1ad PB

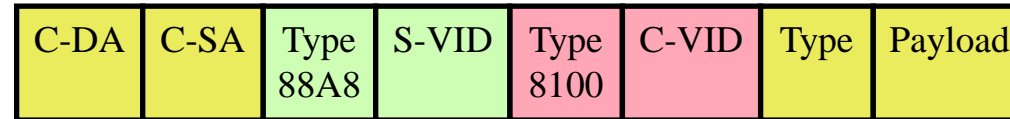

- IEEE 802.1ah PBB or 802.1Qay PBB-TE

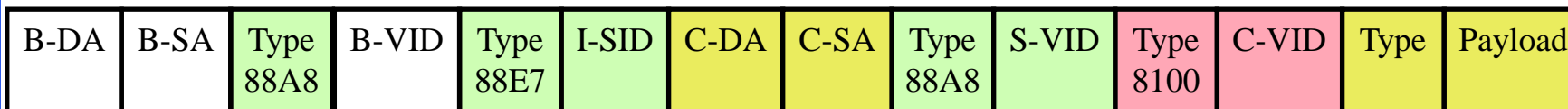

| Tag Type | Value |
|-------------------------------|-------|
| Customer VLAN | 8100 |
| Service VLAN or Backbone VLAN | 88A8 |
| Backbone Service Instance | 88E7 |

Student Questions

Comparison of Technologies

| | Basic Ethernet | MPLS | PB | PBB-TE |
|----------------------------|-----------------------|----------------------------|--------------------------|----------------------------|
| Resilience | No | Protection Fast Reroute | SPB/LAG | Protection Fast Reroute |
| Security | No | Circuit Based | VLAN | Circuit Based |
| Multicast | Yes | Inefficient | Yes | No. P2P only |
| QoS | Priority | Diffserve | Diffserve+ Guaranteed | Diffserve+ Guaranteed |
| Legacy Services | No | Yes (PWE3) | No | No |
| Traffic Engineering | No | Yes | No | Yes |
| Scalability | Limited | Complex | Q-in-Q | Q-in-Q+ Mac-in-MAC |
| Cost | Low | High | Medium | Medium |
| OAM | No | Some | Yes | Yes |

Student Questions

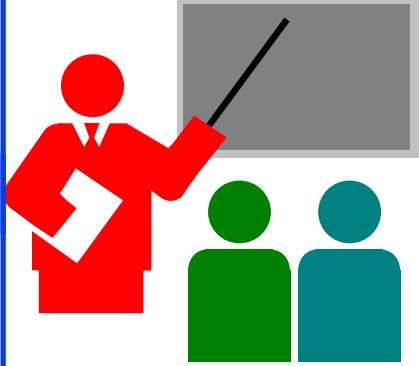

Summary

1. Carriers use User-to-Network Interface (UNI) signaling rather than peer-to-peer signaling
2. Metro Ethernet allows E-Line, E-Access, E-Tree, and E-LAN services
3. Q-in-Q allows service providers to carry customer VLAN tags in their Ethernet Frames
4. MAC-in-MAC extension allows very large Ethernet networks spanning over several backbone carriers
5. PBB-TE extension allows connection oriented Ethernet with QoS guarantees and protection

Student Questions

Reading List

- ❑ Fujitsu, “Carrier Ethernet Essentials,”
<http://www.fujitsu.com/downloads/TEL/fnc/whitepapers/CarrierEthernetEssentials.pdf>
- ❑ R. Santitoro, “Metro Ethernet Services – A Technical Overview,” The Metro Ethernet Forum, 2003, V2.7,
https://www.mef.net/Assets/White_Papers/Metro-Ethernet-Services.pdf

Student Questions

References

- ❑ G. Santana, “Datacenter Virtualization Fundamentals,” Cisco Press, 2014, ISBN: 1587143240 (Safari Book)
- ❑ H. Saboowala, M. Abid, S. Modali, "Designing Networks and Services for the Cloud: Delivering business-grade cloud applications and services," Cisco Press 2013, ISBN:1587142945 (Safari Book)

Student Questions

Wikipedia Links

- ❑ http://en.wikipedia.org/wiki/Carrier_Ethernet
- ❑ http://en.wikipedia.org/wiki/Connection-oriented_Ethernet
- ❑ http://en.wikipedia.org/wiki/Ethernet_Private_Line
- ❑ http://en.wikipedia.org/wiki/Ethernet_Virtual_Private_Line
- ❑ http://en.wikipedia.org/wiki/IEEE_802.1ad
- ❑ http://en.wikipedia.org/wiki/IEEE_802.1ag
- ❑ http://en.wikipedia.org/wiki/IEEE_802.1ah-2008
- ❑ http://en.wikipedia.org/wiki/Metro_Ethernet
- ❑ http://en.wikipedia.org/wiki/Metro_Ethernet_Forum
- ❑ http://en.wikipedia.org/wiki/Network-to-network_interface
- ❑ http://en.wikipedia.org/wiki/Operations,_administration_and_management
- ❑ http://en.wikipedia.org/wiki/Provider_Backbone_Bridge_Traffic_Engineering
- ❑ http://en.wikipedia.org/wiki/Traffic_policing
- ❑ http://en.wikipedia.org/wiki/Traffic_shaping
- ❑ http://en.wikipedia.org/wiki/User%E2%80%93network_interface
- ❑ http://en.wikipedia.org/wiki/Virtual_Private_LAN_Service

Student Questions

Acronyms

- ❑ B-VID Backbone VLAN Identifier
- ❑ BER Bit Error Rate
- ❑ C-VID Customer VLAN Identifier
- ❑ CBS Committed Burst Size
- ❑ CCM Continuity Check Message
- ❑ CE Customer Edge
- ❑ CFI Canonical Form Indicator
- ❑ CFM Connectivity Fault Management
- ❑ CIR Committed Information Rate
- ❑ CM Color Mode
- ❑ CoS Class of Service
- ❑ DA Destination Address
- ❑ DEI Drop Eligibility Indicator
- ❑ DSCP Differentiated Services Code Points
- ❑ EBS Excess Burst Size
- ❑ EC Ethernet Connection

Student Questions

Acronyms (Cont)

- ❑ EIR Excess Information rate
- ❑ ENNI External Network to Network Interface
- ❑ EPL Ethernet Private Line
- ❑ EVC Ethernet Virtual Connection
- ❑ EVP-Access Ethernet Virtual Private Access
- ❑ EVP-LAN Ethernet Virtual Private Local Area Network
- ❑ EVP-Line Ethernet Virtual Private Line
- ❑ EVP-Tree Ethernet Virtual Private Tree
- ❑ EVPL Ethernet Virtual Private Line
- ❑ I-SID Instance Service ID
- ❑ ID Identifier
- ❑ IEEE Institution of Electrical and Electronic Engineers
- ❑ IETF Internet Engineering Task Force
- ❑ IP Internet Protocols
- ❑ ITU International Telecommunications Union

Student Questions

Acronyms (Cont)

- ❑ LAN Local Area Network
- ❑ LTM Link Trace Message
- ❑ LTR Link Trace Response
- ❑ MAC Media Access Control
- ❑ MEG Maintenance Entity Group
- ❑ MEP Maintenance End Points
- ❑ MIP Maintenance Intermediate Points
- ❑ MP Multi-Point
- ❑ MPLS Multi-Protocol Label Switching
- ❑ NNI Network-to-Network Interface
- ❑ OAM Operation, Administration and Maintenance
- ❑ OC Optical Carrier
- ❑ OIF Optical Interoperability Forum
- ❑ OVC Operator Virtual Connection

Student Questions

Acronyms (Cont)

- ❑ PB Provider Bridge
- ❑ PBB-TE Provider Backbone Bridge with Traffic Engineering
- ❑ PBB Provider Backbone Bridge
- ❑ PBBE Provider BackBone Edge
- ❑ PBBN Provider Backbone Network
- ❑ PBEB Provider backbone edge bridges
- ❑ PBN Provider Bridging network
- ❑ PBX Private Branch Exchange
- ❑ PCP Priority Code Point
- ❑ PDH Plesiochronous Digital Hierarchy
- ❑ PE Provider Edge
- ❑ PW Pseudo-Wire
- ❑ PWE3 Pseudo-Wire Emulation Edge-to-Edge
- ❑ QoS Quality of Service
- ❑ S-VID Service (Provider) VLAN ID
- ❑ SA Source Address
- ❑ SDH Synchronous Digital Hierarchy

Student Questions

Acronyms (Cont)

- ❑ SID Service Identifier
- ❑ SLA Service Level Agreement
- ❑ SONET Synchronous optical network
- ❑ TE Traffic Engineering
- ❑ TV Television
- ❑ UCA Use Customer Address (flag)
- ❑ UNI User to Network Interface
- ❑ VID VLAN Identifier
- ❑ VLAN Virtual Local Area Network
- ❑ VoD Video on Demand
- ❑ VoIP Voice over IP
- ❑ VPN Virtual Private Network

Student Questions

Scan This to Download These Slides



Raj Jain

<http://rajjain.com>

http://www.cse.wustl.edu/~jain/cse570-21/m_06cee.htm

Student Questions

Related Modules



CSE567M: Computer Systems Analysis (Spring 2013),

https://www.youtube.com/playlist?list=PLjGG94etKypJEKjNAa1n_1X0bWWNyZcof

CSE473S: Introduction to Computer Networks (Fall 2011),

https://www.youtube.com/playlist?list=PLjGG94etKypJWOSPMh8Azcg5e_10TiDw



Wireless and Mobile Networking (Spring 2016),

https://www.youtube.com/playlist?list=PLjGG94etKypKeb0nzyN9tSs_HCd5c4wXF

CSE571S: Network Security (Fall 2011),

<https://www.youtube.com/playlist?list=PLjGG94etKypKvzfVtutHcPFJXumyyg93u>



Video Podcasts of Prof. Raj Jain's Lectures,

<https://www.youtube.com/user/ProfRajJain/playlists>

Student Questions