

# Computer Networks and the Internet

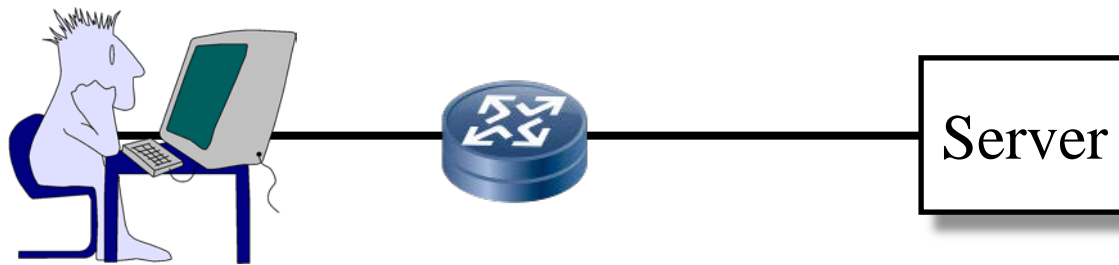

**Raj Jain**

Washington University in Saint Louis

Saint Louis, MO 63130

Jain@wustl.edu

Audio/Video recordings of this lecture are available on-line at:

<http://www.cse.wustl.edu/~jain/cse473-25/>

## Student Questions

- ❑ Can you provide the slides (ppt or pdf) since it's convenient to take notes directly on them?

*Yes. All slides are on the course website. URL is on every slide.*

---

*Please answer all quiz questions on the video. Also, please enter at least one question on the Google form to get a grade for that assignment.*



- ❑ What is Internet?
- ❑ Switching: Circuit vs. Packet
- ❑ Edge vs. Core
- ❑ Network Performance Measures: Delay, Loss, Throughput
- ❑ Protocol Layers
- ❑ Network Security
- ❑ History

**Note:** This class lecture is based on Chapter 1 of the textbook (Kurose and Ross) and the slides provided by the authors.

## Student Questions

- ❑ Are we required to read the textbook?  
*Yes. After watching the video. Maybe after the Q&A session when the video is completely understood. You can ask additional questions anytime.*
- ❑ Since Chapter 1 is a broad overview, will we be required to know about every layer at a surface level? Or what is the extent of knowledge for chapter 1? It seems like it discusses mainly the physical layer.  
*Yes, Chapter 1 discusses the topics listed on this slide. You need to know things at this level of detail. For example, you should know what layer 3 (IP) does, but you may not know how it does it.*
- ❑ Where are we supposed to take the exam (location)?

*Lopata Hall 101*

# What is a Network?

- ❑ **Network:** Enables data transfer among nodes
  - Generally heterogeneous nodes
  - More than **two** nodes
  - E.g., Your home or office network

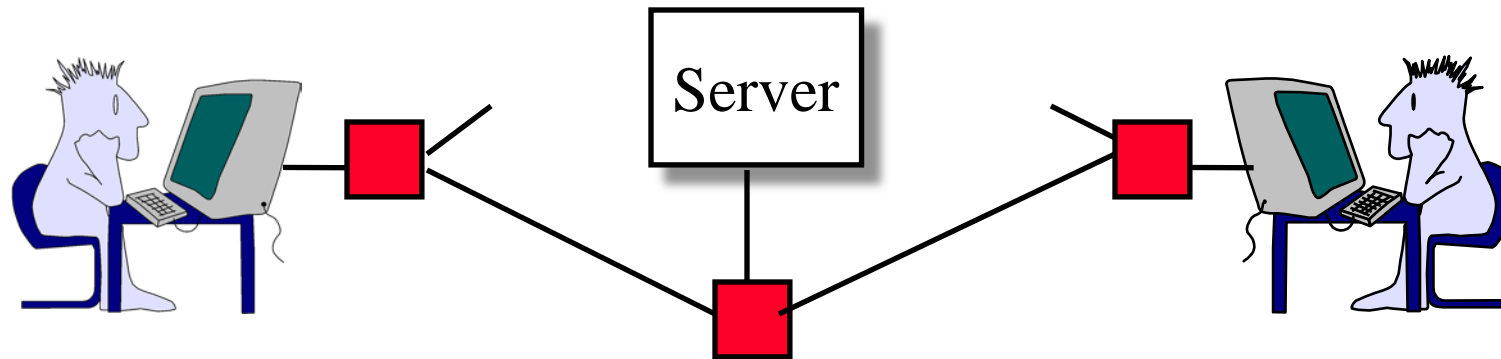

- ❑ **Communication:** Two nodes.
  - Link-level electrical issues.



## Student Questions

- ❑ Can multiple nodes exist in one physical device? If so, can we treat one physical device with various nodes as a network?

*Yes. Yes.*

- ❑ What are heterogeneous nodes?

*Homogeneous=Similar*

*Heterogeneous=It may not be similar.*

- ❑ What are nodes? Is it a point where a connection is established between two points?

*A node is any device connected to the network.*

- ❑ How are nodes defined in this context?

*See above.*

- ❑ Can we view a network as a collection of communications?

*Interconnection of communication links*

- ❑ What do heterogeneous nodes mean?

*See above...*

- ❑ What does it mean for two nodes to be heterogeneous?

*Homogeneous=same kind, e.g., both servers or both clients*

- ❑ Are there some older devices that we do not use anymore?

*Yes. We will talk about hubs in Chapter 6.*

# What is a Network?

- ❑ **Network:** Enables data transfer among nodes
  - Generally heterogeneous nodes
  - More than **two** nodes
  - E.g., Your home or office network

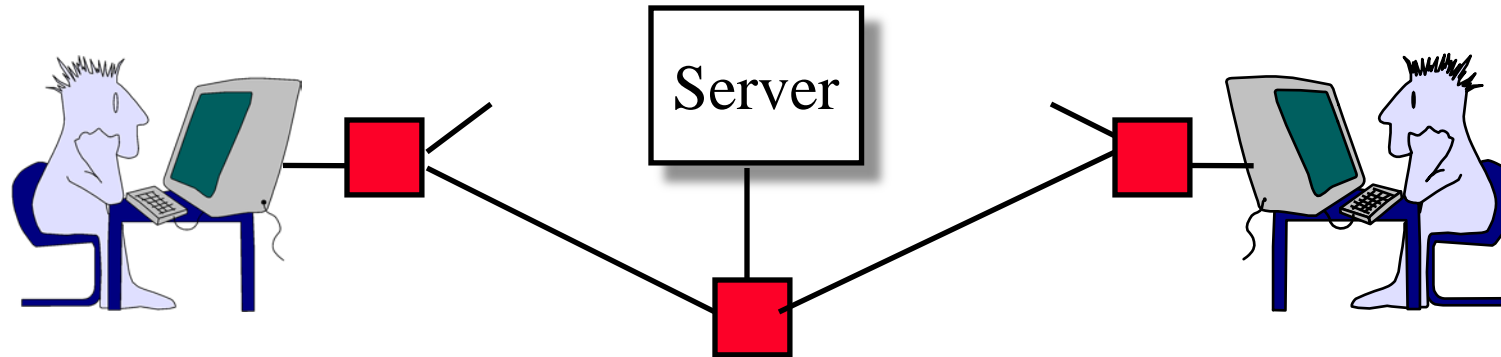

- ❑ **Communication:** Two nodes.
  - Link-level electrical issues.



## Student Questions

- ❑ Can you define nodes? Do you mean devices?

*That subset of devices that is connected to the network is a node.*

# Key Concepts



- ❑ **End Systems:** Systems that are sinks or sources of data, e.g., Desktops, Laptops, Servers, Printers, Cell Phones, etc.
- ❑ **Intermediate Systems:** Systems that forward/switch data from one link to another, e.g., routers, switches
- ❑ **Hosts:** End Systems
- ❑ **Gateways:** Routers
- ❑ **Servers:** End Systems that provide service, e.g., print server, storage server, Mail server, etc.
- ❑ **Clients:** End systems that request service
- ❑ **Links:** Connect the systems.  
Characterized by transmission rate, propagation delay

## Student Questions

- ❑ Could an intermediate system be considered a link?

*Link is usually a medium, e.g., wire or radio, or light.*

- ❑ Could the service of linking two nodes characterize a system as a server?

*Not necessarily. A router is an intermediate system. Even though they are providing the routing service, we don't typically call them servers, particularly since they are invisible.*

- ❑ Are there end systems that don't request service? (e.g., non-clients)

*Yes, some end systems, e.g., sensors, provide service. Some monitor the network. Etc.*

- ❑ So the servers could be called host, and a client could also be called host?

*Yes.*

- ❑ What specifically do routers do?

*Routers forward packets*

- ❑ How do we distinguish between intermediates and links?

*Systems can store and forward packets. Links simply pass the bits from one end to another, like houses vs. roads.*

# Key Concepts



- ❑ **End Systems:** Systems that are sinks or sources of data, e.g., Desktops, Laptops, Servers, Printers, Cell Phones, etc.
- ❑ **Intermediate Systems:** Systems that forward/switch data from one link to another, e.g., routers, switches
- ❑ **Hosts:** End Systems
- ❑ **Gateways:** Routers
- ❑ **Servers:** End Systems that provide service, e.g., print server, storage server, Mail server, etc.
- ❑ **Clients:** End systems that request service
- ❑ **Links:** Connect the systems.  
Characterized by transmission rate, propagation delay

## Student Questions

- ❑ What is the difference between hosts and servers?

*Hosts=Nodes*

*Types of Node: Servers and Clients*

- ❑ Is Gateway included in the Intermediate system?

*Yes.*

- ❑ What is the difference between a router and a switch?

*It will be clear after we cover the protocol layers.*

- ❑ If I transmit data to the server, and then the server transmits data to another computer, is the server an End System or an Intermediate System?

*It is an end system since its primary function is not forwarding.*

- ❑ What are some gateway examples before we use Wi-Fi and routers?

*Routers*

- ❑ What is the difference between routers and switches?

*Routers: Layer 3 devices (speak IPv4, IPv6, ...)*

*Switches: Layer 2 devices (speak Ethernet, WiFi, ...)*

# Key Concepts



- ❑ **End Systems:** Systems that are sinks or sources of data, e.g., Desktops, Laptops, Servers, Printers, Cell Phones, etc.
- ❑ **Intermediate Systems:** Systems that forward/switch data from one link to another, e.g., routers, switches
- ❑ **Hosts:** End Systems
- ❑ **Gateways:** Routers
- ❑ **Servers:** End Systems that provide service, e.g., print server, storage server, Mail server, etc.
- ❑ **Clients:** End systems that request service
- ❑ **Links:** Connect the systems.  
Characterized by transmission rate, propagation delay

## Student Questions

- ❑ Since hosts are end systems, why do we use two different terms for the same thing?

*Names originated at different times.*

- ❑ Is the management interface of a router also considered an end system?

*An interface is not a system. The router is a system. Its primary function is routing=intermediate system.*

- ❑ How would a hardware firewall fit into these concepts?

*It is an intermediate system.*

- ❑ Is the definition/distinction of "Sink" and "source" the same as in graph theory? Are the distinctions between sink and source important under specific contexts, considering that most modern endpoints seem to work as both?

*Yes. Many systems can be both. Not sure about graph theory.*



# Key Concepts



- ❑ **End Systems:** Systems that are sinks or sources of data, e.g., Desktops, Laptops, Servers, Printers, Cell Phones, etc.
- ❑ **Intermediate Systems:** Systems that forward/switch data from one link to another, e.g., routers, switches
- ❑ **Hosts:** End Systems
- ❑ **Gateways:** Routers
- ❑ **Servers:** End Systems that provide service, e.g., print server, storage server, Mail server, etc.
- ❑ **Clients:** End systems that request service
- ❑ **Links:** Connect the systems.  
Characterized by transmission rate, propagation delay

## Student Questions

- ❑ How is a router a gateway and an intermediate system, but a switch is only an intermediate system + not a gateway?

*It will become clear when we define layers. Switches are Layer 2 nodes, while gateways are Layer 3.*

- ❑ Is this correct? There are three nodes (a client PC, a server, and an intermediate system between them) connected by two links, and both the PC and server are end systems/hosts.

*Yes.*

- ❑ Do End Systems need to communicate with each other through Intermediate Systems?

*Sometimes, they can talk directly.*



# Key Concepts



- ❑ **End Systems:** Systems that are sinks or sources of data, e.g., Desktops, Laptops, Servers, Printers, Cell Phones, etc.
- ❑ **Intermediate Systems:** Systems that forward/switch data from one link to another, e.g., routers, switches
- ❑ **Hosts:** End Systems
- ❑ **Gateways:** Routers
- ❑ **Servers:** End Systems that provide service, e.g., print server, storage server, Mail server, etc.
- ❑ **Clients:** End systems that request service
- ❑ **Links:** Connect the systems.  
Characterized by transmission rate, propagation delay

## Student Questions

- ❑ Can a switch ever be a gateway?

*Yes. Switch and Gateway refer to the functions. There are multi-function devices.*

- ❑ Does the information always take the shortest path, or are there reasons for it to take another path?

*It may take another path for security or other reasons.*

- ❑ Are there specific examples of end systems that only sink or are only sources of data, or are all systems capable of being both?

*A thermostat may only broadcast temperature. My phone only collects temperature data.*

# What is Internet?

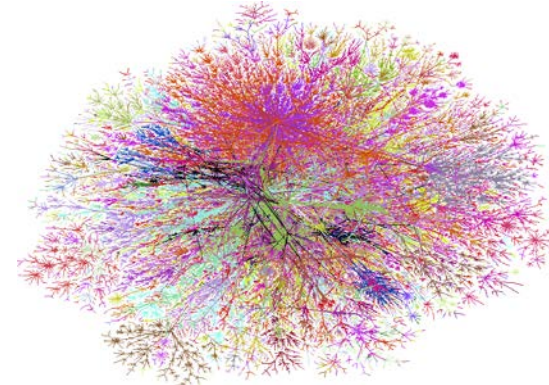
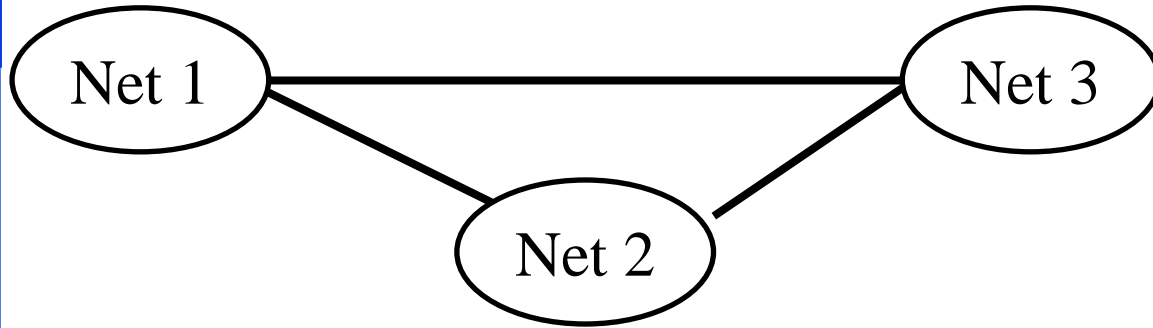

- ❑ Internet = Inter-Network = Network connecting networks
- ❑ Approximately 1.05B hosts on the Internet in 2016.
- ❑ ISP: **Internet Service Provider**.
  - Provide access to the Internet.
  - Telecommunications (Telephone) Companies, AT&T, Verizon, Comcast, ...
  - Coffee Shops (Wi-Fi)

## Student Questions

- ❑ Why are coffee shops considered ISP?  
*They provide Internet service.*
- ❑ What makes phone calls become free?  
*The Internet is basically free.*
- ❑ Do ISPs have levels? (Maybe it is the Tier mentioned later in the lecture). For example, if the coffee shops are using AT&T, but I am using Wi-Fi provided by the coffee shops, which is my ISP?  
*Your ISP is the coffee shop.*
- ❑ Since the Internet is, from what I understand, a network of networks, what would the links between each network be in this case, and could it be possible that a network would serve as the link between 2 other networks?  
*Yes. Two networks can be connected by one link or more than one link (network).*
- ❑ Can one host be connected to another via the Internet?  
*Yes, that's what the Internet does*

Ref: <http://www.statista.com/statistics/264473/number-of-internet-hosts-in-the-domain-name-system/>

# What is Internet?

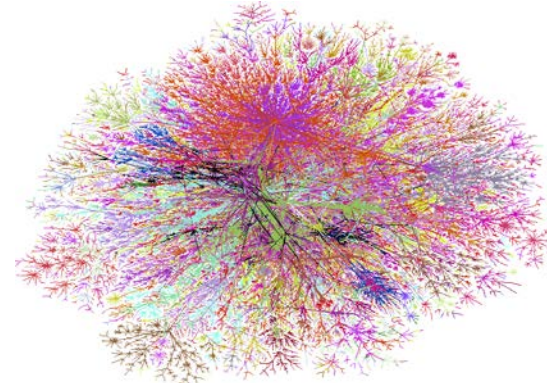
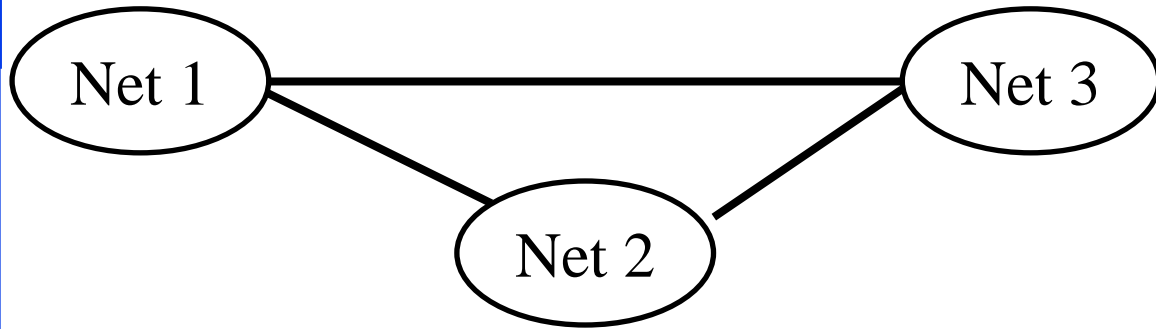

- ❑ Internet = Inter-Network = Network connecting networks
- ❑ Approximately 1.05B hosts on the Internet in 2016.
- ❑ ISP: **Internet Service Provider**.
  - Provide access to the Internet.
  - Telecommunications (Telephone) Companies, AT&T, Verizon, Comcast, ...
  - Coffee Shops (Wi-Fi)

Ref: <http://www.statista.com/statistics/264473/number-of-internet-hosts-in-the-domain-name-system/>

## Student Questions

- ❑ How do ISPs connect all these networks to one another?

*There are levels (tiers) of ISP. Tier 3 is connected by Tier 2. Tier 2 is connected by Tier 1. To be covered shortly.*

- ❑ Why could a coffee shop be an ISP? Shouldn't it be the telecommunication company that sets up the connection to the coffee shop?

*The telecommunication company is ISP for the coffee shop.*

- 
- ❑ If my phone shares personal hotspots with other devices, is my phone an ISP?

*Yes, it is if you provide this as a service to the general public. That is, start charging for it, and anyone can sign up. This generally requires registration with the FCC.*

---

# What is Internet?

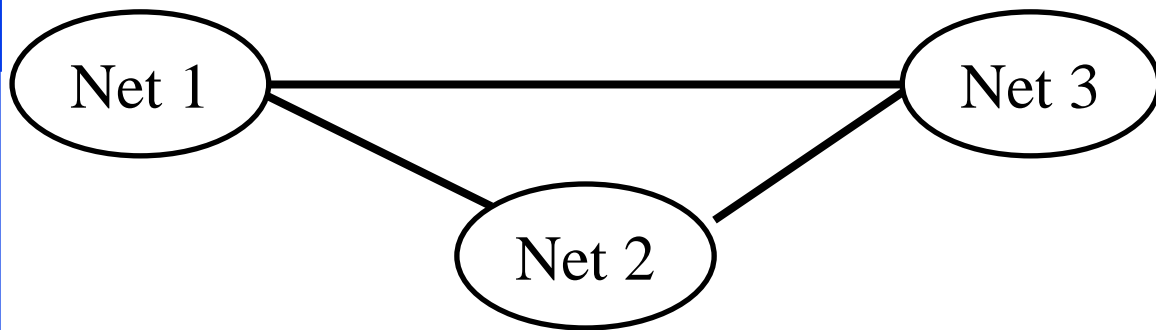

- ❑ Internet = Inter-Network = Network connecting networks
- ❑ Approximately 1.05B hosts on the Internet in 2016.
- ❑ ISP: **Internet Service Provider**.
  - Provide access to the Internet.
  - Telecommunications (Telephone) Companies, AT&T, Verizon, Comcast, ...
  - Coffee Shops (Wi-Fi)

## Student Questions

- ❑ I use a Coffee shop's Wi-Fi. The telecommunication company that set up the wifi for the coffee shop is the ISP for the coffee shop, and the coffee shop is my ISP. Is it an example of tiers? Is the coffee shop considered to be tier 3? Also, if I use 4G and I broadcast and share it with my friends, I should be their ISP, right? Am I tier 3?

*The coffee shop and you are an ISP if you charge for such services and offer them to the general public.*

Ref: <http://www.statista.com/statistics/264473/number-of-internet-hosts-in-the-domain-name-system/>

# Types of Networks

## □ Point to point vs. Broadcast

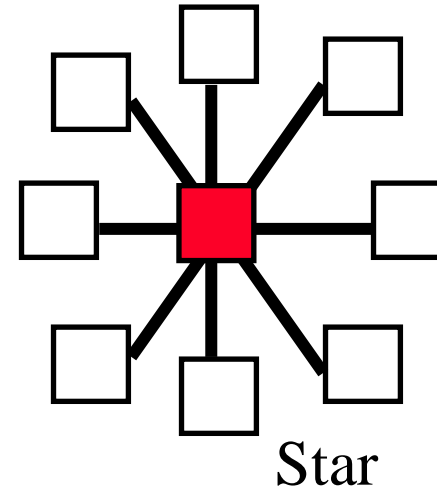
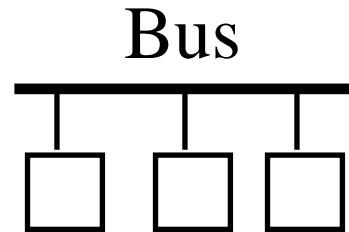
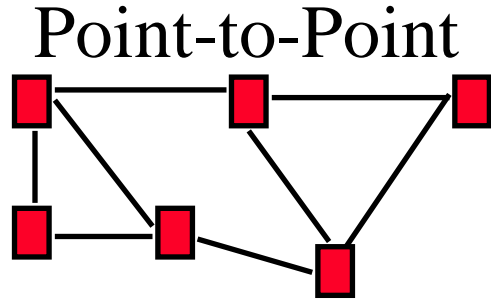

## □ Circuit-switched vs. packet-switched.

- **Circuit:** A path (circuit) is set up before transmission. All bits follow the same path, e.g., the Phone
- **Packet:** Packets of bits are forwarded individually

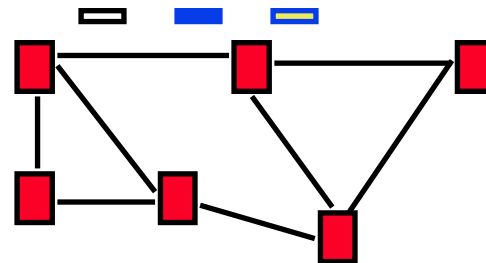
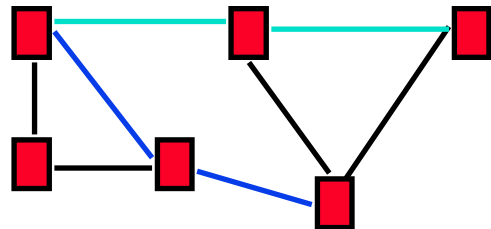

## Student Questions

- In what cases, if any, are circuit-switched networks used?

*Phone network*

- Can wireless connections only use packet-switching? Therefore, is circuit-switching not as prevalent?

*Wireless can use both circuit and packet switching. Circuit-switched networks exist but are less prevalent.*

- Did this mean that a circuit can be bidirectional, and a packet is unidirectional?

*Both can be bidirectional or unidirectional.*

- Is a circuit (path) always physical?

*No. There are virtual circuits.*

- How does the packet know the address of where to go if the connection has not been set up beforehand, like the circuit?

*The address is put on the packet by the sender.*

- What would an example of a star network type be? *Your home Ethernet or Wi-Fi.*
- Is it possible to combine the types of networks? For example, use a star network as the base where each node that extends from the center is a bus network itself.

*Yes.*

# Types of Networks

## Point to point vs. Broadcast

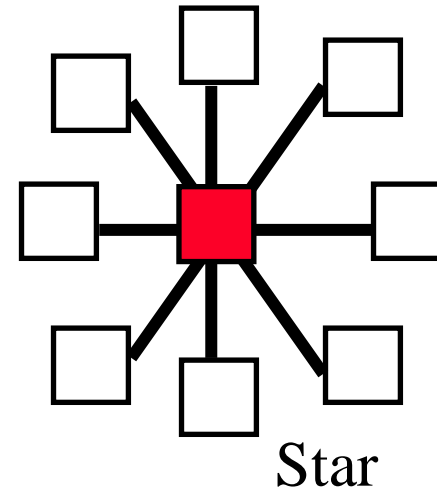
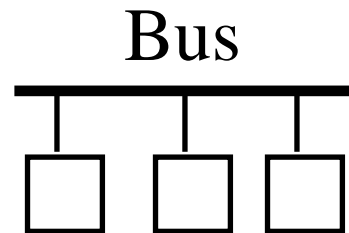
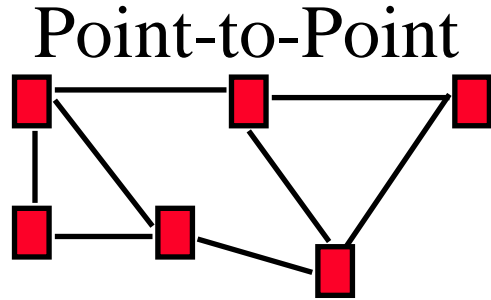

## Circuit-switched vs. packet-switched.

- **Circuit:** A path (circuit) is set up before transmission. All bits follow the same path, e.g., the Phone
- **Packet:** Packets of bits are forwarded individually

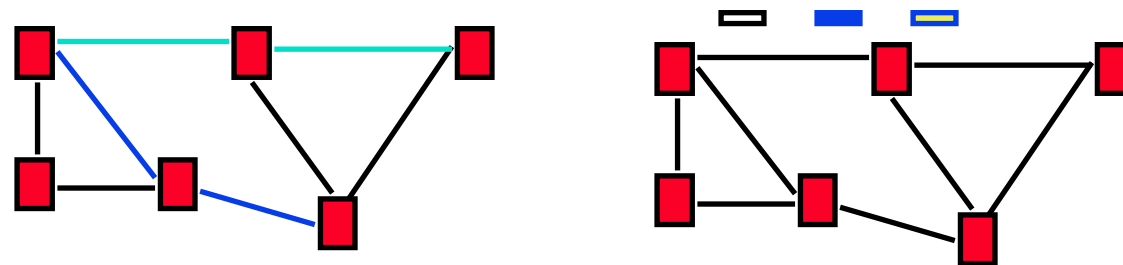

## Student Questions

- ❑ Do each 2 nodes have a link in Point-to-Point networks?  
*Each node should have at least one link. Every pair of nodes may not have a direct link.*
- ❑ Would a point-to-point network be inefficient in the sense that it requires every node to be connected to every other node, effectively creating/maintaining a very large number of connections per node?  
*Point-to-point does not require "full mesh."*
- ❑ What happens when more than one node broadcasts a message on the bus network? Is there a clash if they are going in opposite directions? How is it resolved?  
*Yes. There are collisions. There are protocols to take care of it.*
- ❑ Why would we ever use a Star network in the manner where the central node sends messages out to everyone? Isn't that just a Bus, but with added resources and likely latency?  
*Star is easier to maintain.*



# Types of Networks

## Point to point vs. Broadcast

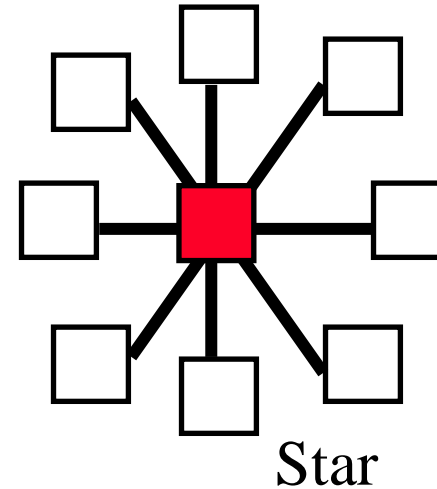
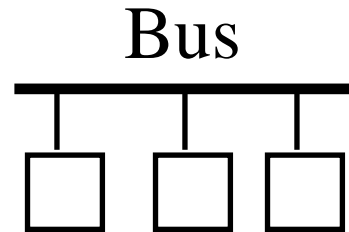
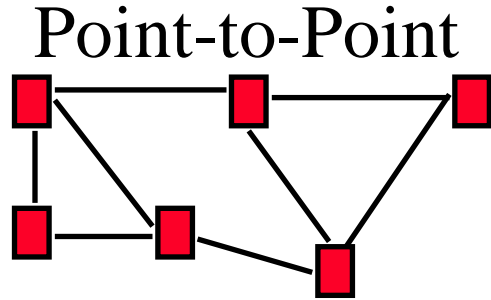

## Circuit-switched vs. packet-switched.

- **Circuit:** A path (circuit) is set up before transmission. All bits follow the same path, e.g., the Phone
- **Packet:** Packets of bits are forwarded individually

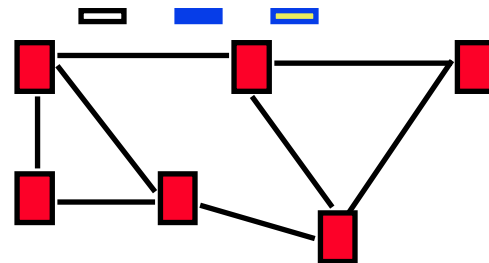
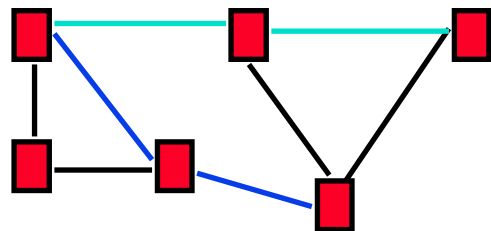

## Student Questions

- ❑ I don't quite understand the difference between point-to-point and switches since they look almost the same. And you said 99.9% use a star as the pattern. Does that mean the switch is the updated version of a star pattern?

*Switches may be centers of stars. But, switches may be connected to other switches in any topology.*

- ❑ What's the center of a star network? Must it be a router or server?

*Router or a switch*

- ❑ Is the star network considered point-to-point?

*Yes*

- ❑ Do landline phones still use circuit connections, or are those VoIP also?

*Depends on the provider.*

- ❑ Is the coaxial connection circuit switched or packet switched?

*It could be either. Coaxial=wire.*

- ❑ What advantage does a star have compared to a bus?

*Easier to maintain since star point is in a closet and not all over.*



# Types of Networks

## Point to point vs. Broadcast

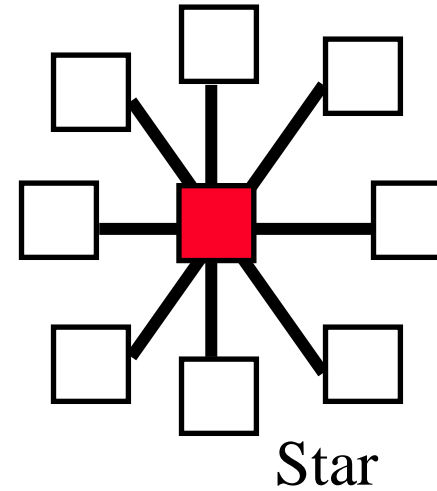
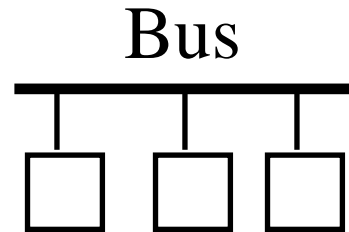
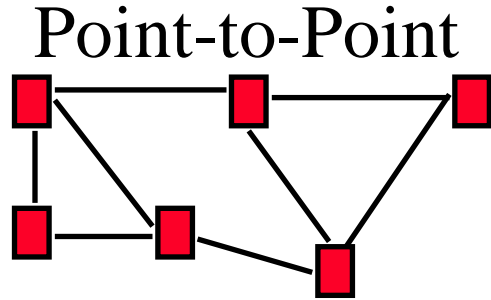

## Circuit-switched vs. packet-switched.

- **Circuit:** A path (circuit) is set up before transmission. All bits follow the same path, e.g., the Phone
- **Packet:** Packets of bits are forwarded individually

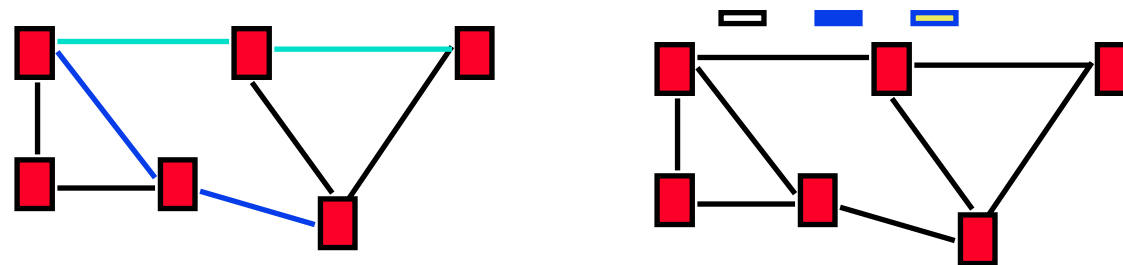

## Student Questions

- ❑ Suppose the network is a star. When it broadcasts, if I set my device id as another one's, does it mean my device can 'steal' another device's data?

*Most routers and switches will not allow that without an administrative override.*

- ❑ Can we have some examples of the use of different networks?

*Star=With Switches and routers (most common)*

*Point-to-Point without star: Inter-carrier*

*Bus=Original Ethernet in the 1980s*

- ❑ Can Star network be viewed as Point-to-Point network?

*Yes.*

- ❑ When we establish an end-to-end system, does the total transmission time depends on the number of links in this system?

*No, the transmission time at each node in the path is determined by the link it is transmitting on. Total delay depends on queuing delays, transmission time,s and propagation times.*

- ❑ What is the difference between a point-to-point network and a Star network?

*Point-to-point is more general.*

# Types of Networks

## Point to point vs. Broadcast

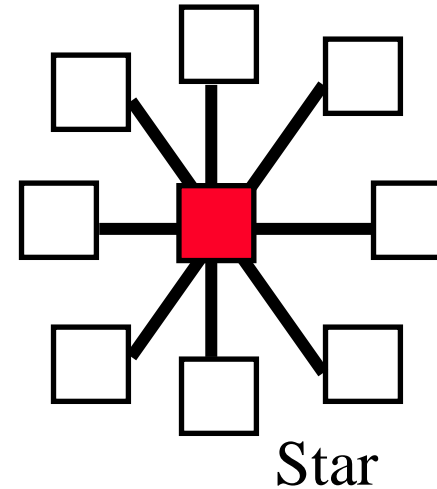
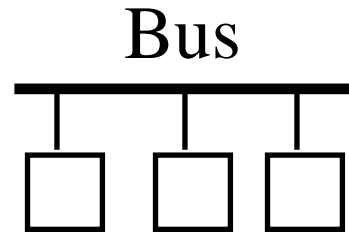
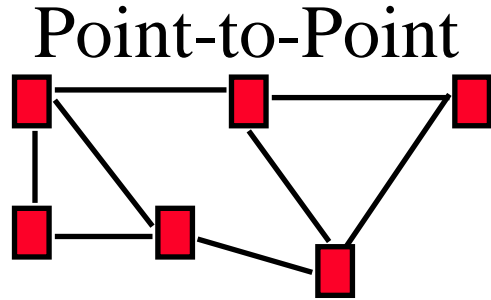

## Circuit-switched vs. packet-switched.

- **Circuit:** A path (circuit) is set up before transmission. All bits follow the same path, e.g., the Phone
- **Packet:** Packets of bits are forwarded individually

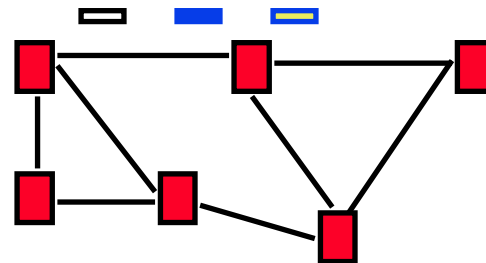
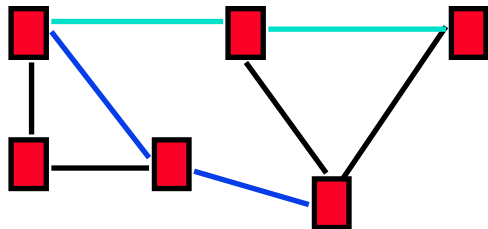

## Student Questions

- ❑ What is considered Broadcast?  
*Everyone can hear it.*
- ❑ So, in this broadcast case, Is only the machine that receives the data called End System, or can all machines be called the End System?  
*End = Primary job is not forwarding.*
- ❑ How do packets find the correct address?  
*Layer 3 is to be covered in Chapter 4.*
- ❑ What would be an example of point-to-point networking?  
*If you have a switch/router, that's a star network.*
- ❑ Does anyone use point-to-point networking now, as opposed to star networking?  
*Yes, inter-carrier networks may use point-to-point.*
- ❑ Is each packet transferred via different routes? May the second packet arrive earlier than the first one?  
*Yes*
- ❑ Do the star network branches have many points? To make the star with many out layers.  
*The question needs to be clarified. You can have a star of stars.*

# Types of Networks

## Point to point vs. Broadcast

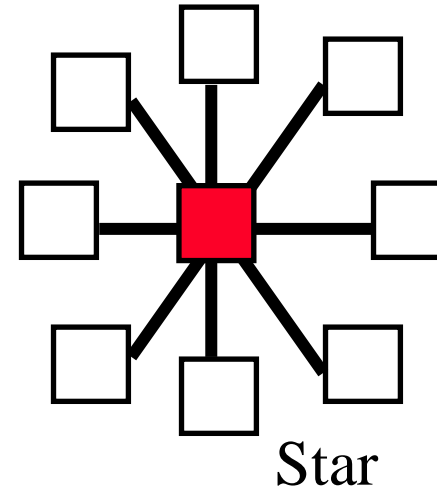
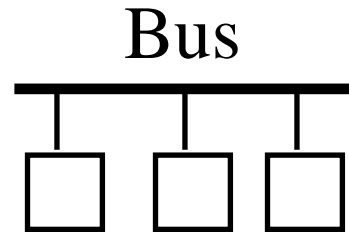
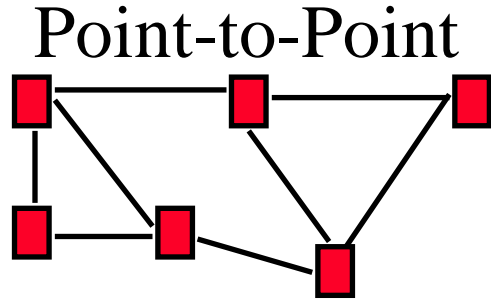

## Circuit-switched vs. packet-switched.

- **Circuit:** A path (circuit) is set up before transmission. All bits follow the same path, e.g., the Phone
- **Packet:** Packets of bits are forwarded individually

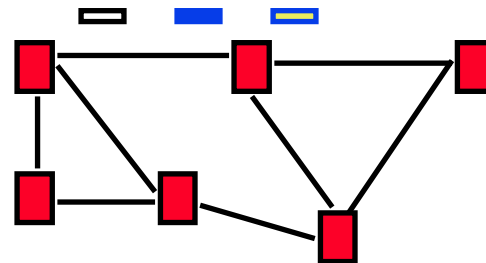
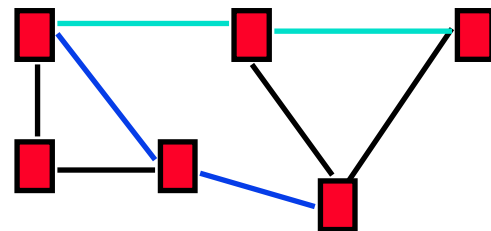

## Student Questions

- ❑ What are virtual circuits? Where are they used? Please give examples. What would an example of a bus network type be?

*Virtual circuits are used in telephone networks, where a single wire is used to send multiple calls (circuits).*

- ❑ What does it look like for a circuit to be established virtually?

*Opposite of physical setup.*

- ❑ What would an example of a point-to-point network type be?

*Current Ethernet links.*

- ❑ What is VoIP?

*Voice over IP, e.g., WhatsApp*

- ❑ Does Internet topology continue to take a "star" shape beyond the access networks (i.e., on the ISP side), organized hierarchically?

*ISP networks are organized hierarchically but individual networks are point to point mesh.*

- ❑ Are there any upsides to circuit-switched networks in today's hardware and network infrastructure?

*Yes. Covered in CSE 570.*

# Types of Networks

## Point to point vs. Broadcast

Point-to-Point

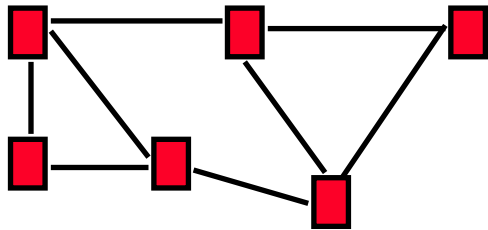

Bus

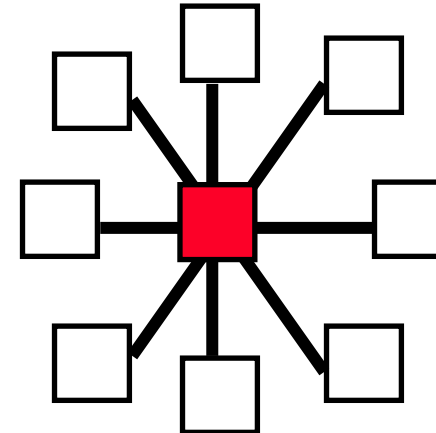
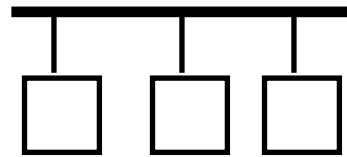

Star

## Circuit-switched vs. packet-switched.

- **Circuit:** A path (circuit) is set up before transmission. All bits follow the same path, e.g., the Phone
- **Packet:** Packets of bits are forwarded individually

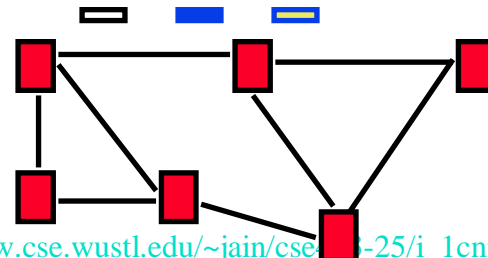
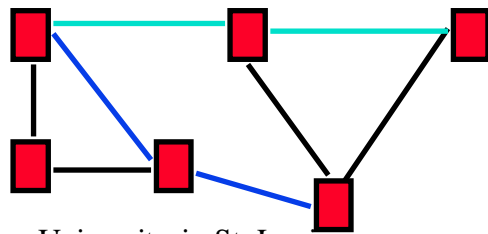

## Student Questions

- ❑ Can circuit vs packet switching be considered synchronous vs. asynchronous, respectively?  
*No. All combinations are possible.*
- ❑ Can lost packets be recovered?  
*Yes, by retransmission.*
- ❑ Is a packet simply a small bunch of bits that are part of a message, or is there more to it in the context of networks?  
*There is more, but this is ok for now.*

---

- ❑ Is there a reason to choose a particular type/network layout over another? What is a system where one is better?  
*We will see examples throughout the course.*
- ❑ In a star network, is the center unit a server or a router/switch/gateway?  
*It could be either one.*
- ❑ Are you able to mix the different types of topologies?  
*Yes.*

---

- ❑ Are two devices connected by Ethernet cable considered a circuit? *No. That's a single link.*

# Types of Networks

## □ Point to point vs. Broadcast

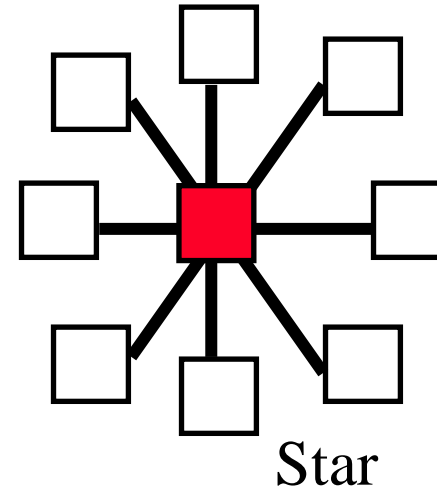
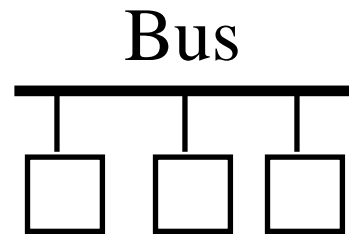
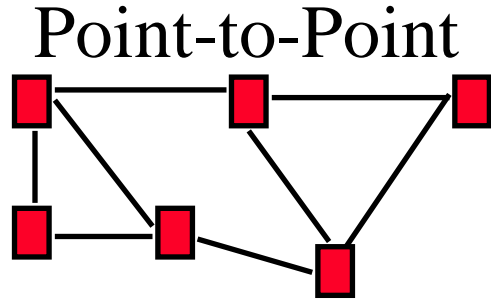

## □ Circuit-switched vs. packet-switched.

- **Circuit:** A path (circuit) is set up before transmission. All bits follow the same path, e.g., the Phone
- **Packet:** Packets of bits are forwarded individually

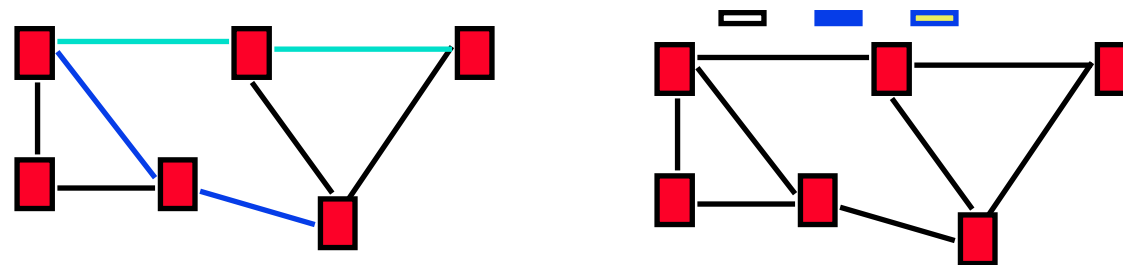

## Student Questions

- For circuit and packet-switched, are they the same path, except for packet-switched, the path isn't set up ahead of time?  
*In the circuit switch, all bits follow the circuit. In packet-switched, different packets can have different paths.*
- What does adding a new node into a circuit-switched network look like vs. a packet-switched one? Are there any differences in how the network recognizes the new node and begins exchanging data?

*Not part of this module.*

- Is there a reason to choose a particular type/network layout over another? What is a system where one is better?  
*We will see examples throughout the course.*
- In a star network, is the center unit a server or a router/switch/gateway?

*It could be either one.*

- Will there be collisions in packet-switched mode?

*Yes. We need protocols to avoid collisions.*

# Types of Networks

## □ Point to point vs. Broadcast

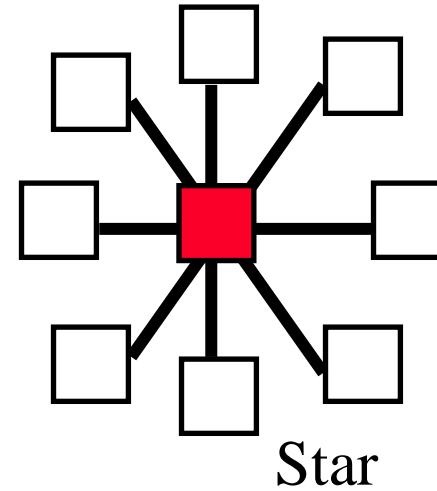
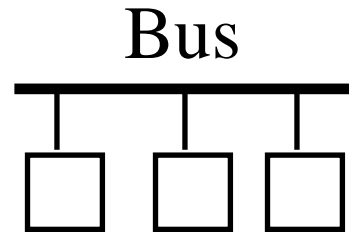
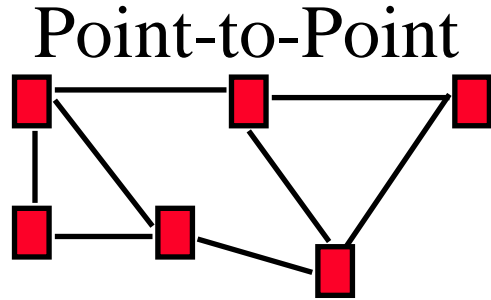

## □ Circuit-switched vs. packet-switched.

- **Circuit:** A path (circuit) is set up before transmission. All bits follow the same path, e.g., the Phone
- **Packet:** Packets of bits are forwarded individually

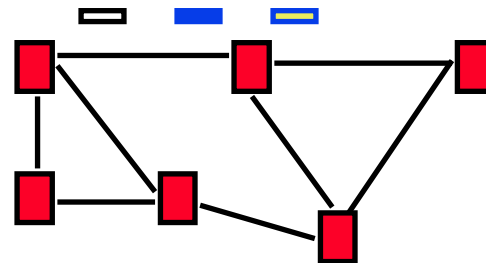
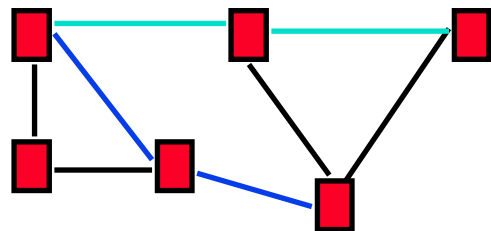

## Student Questions

- Is the star network both point-to-point and broadcast because it can send packets to either everyone or a specific address?

*Yes.*

- Is a public Wi-Fi network typically implemented using a Star Network? Do we use multiple routers to ensure signal coverage?

*Yes.*

- Does the bus send the packets only to the right person, or does it go to everyone, but only the right person accepts it?

*It goes to everyone, but only the right person accepts it.*

# Types of Networks

## □ Point to point vs. Broadcast

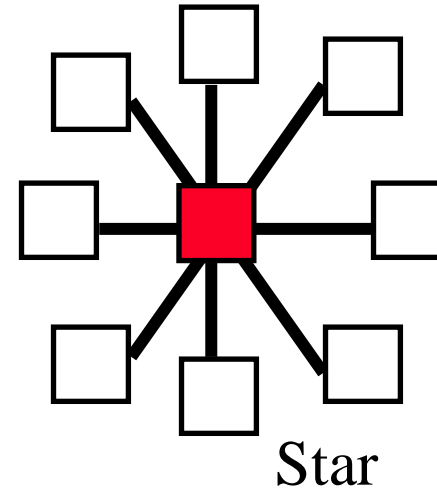
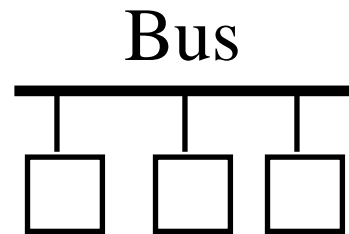
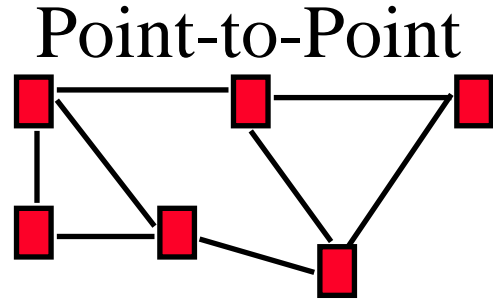

## □ Circuit-switched vs. packet-switched.

- **Circuit:** A path (circuit) is set up before transmission. All bits follow the same path, e.g., the Phone
- **Packet:** Packets of bits are forwarded individually

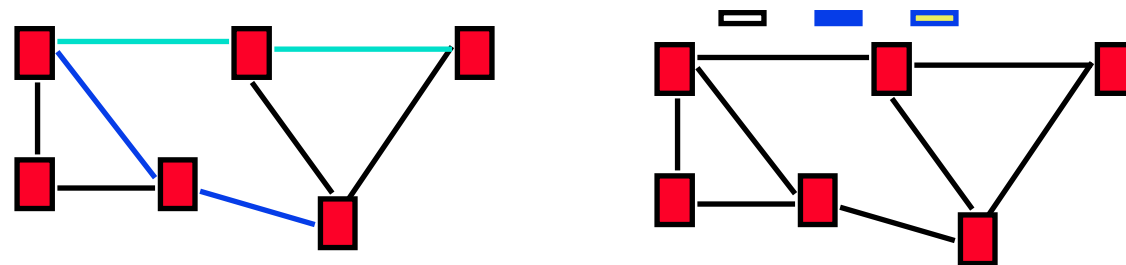

## Student Questions

- I remember coaxial having T connectors. Was that a bus network? *Yes.*
- Is Token Ring also a kind of point-to-point topology, just that it's unidirectional?

*The token ring was point-to-point, but it was bidirectional.*

- Why is the Internet based on packet switching instead of circuit switching?

*Packet switching is good for variable rate traffic data traffic and is fault resistant.*

- How is circuit switching and packet switching used in wireless communication?

*Now packet switching is universal.*





# Multiplexing

How can multiple users share a link?

## ❑ Time Division Multiplexing (TDM)

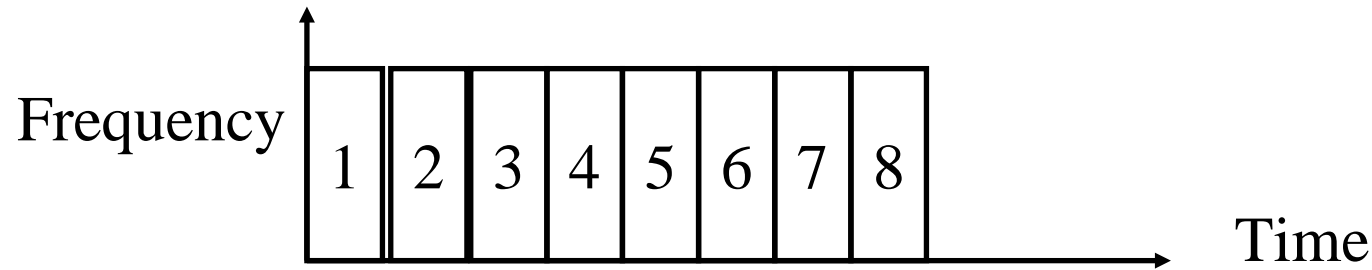

## ❑ Frequency Division Multiplexing (FDM)

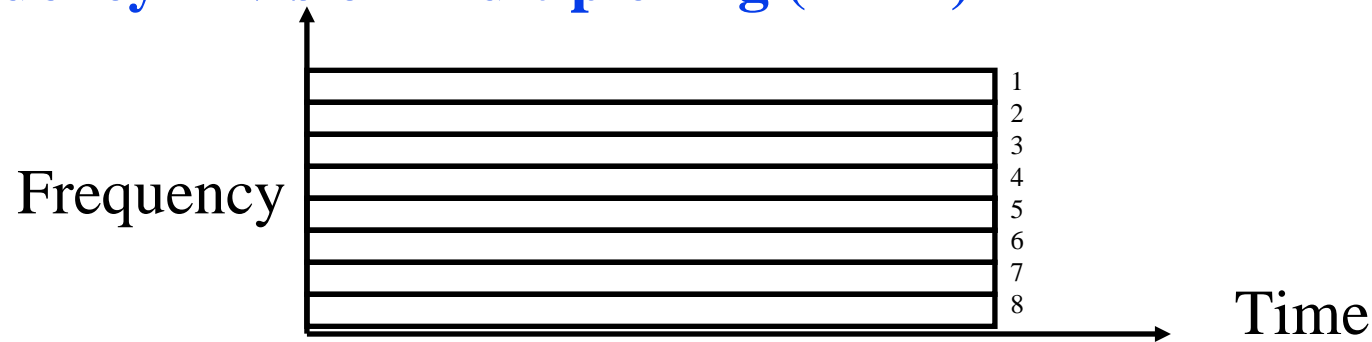

❑ Other multiplexing methods will be covered as needed.

## Student Questions

- ❑ Which multiplexing methods are more popular nowadays?  
*Both. Plus a few others.*
- ❑ Is FDM more efficient compared to TDM since if we have a lot of clients and we use TDM, the delay a client receives grows linearly with the number of clients?  
*No. There are many considerations-- Scalability, burstiness of usage, etc.*
- ❑ Did dial-up networks not use multiplexing? (Since you could not use the internet and phone at the same time).  
*They multiplexed many users on the same trunk line.*
- ❑ Is multiplexing only used in the circuit-switched? *TDM is also multiplexing.*
- ❑ Why would one multiplexing method (TDM/FDM) be preferable/used over the other? *Scalability, efficiency,*
- ❑ In a circuit-switched network, does information still need to be divided into multiple packets?  
*It is not necessary, but you can.*



# Multiplexing

How can multiple users share a link?

## ❑ Time Division Multiplexing (TDM)

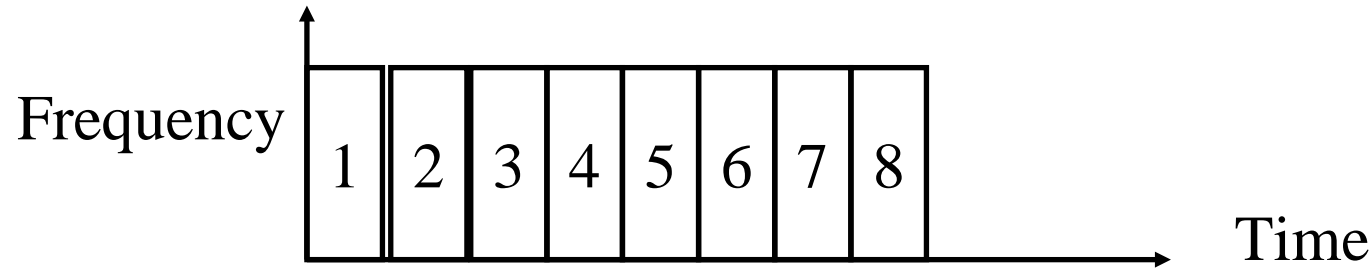

## ❑ Frequency Division Multiplexing (FDM)

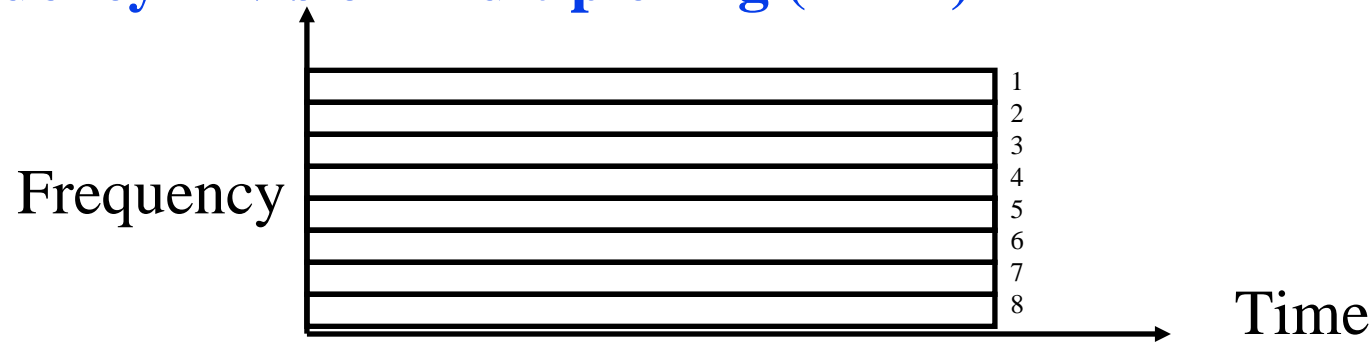

❑ Other multiplexing methods will be covered as needed.

## Student Questions

- ❑ Are there limitations to what style of multiplexing one can use based on the type of network associated?

*Yes. But you can virtualize and provide any type of service over any time of the network.*

- ❑ Is there a mixed pattern between TDM and FDM?

*Yes.*

- ❑ Was ethernet TDM because it is a bus network? Is it still TDM, even though it is used in star networks?

*Yes. Ethernet is still TDM.*

- ❑ Is multiplexing used to handle the problem that several connections share the same link? How can we guarantee connections do not interfere with each other? Is multiplexing only happening in the circuit-switched?

*No TDM is multiplexing. Proper resource allocation can prevent interference.*

- ❑ What is the disadvantage of FDM?

*Allocated but not used can be wasted.*

- ❑ Is using TDMA somewhat like TDM?

*TDMA=TDM Access*



# Multiplexing

How can multiple users share a link?

## ❑ Time Division Multiplexing (TDM)

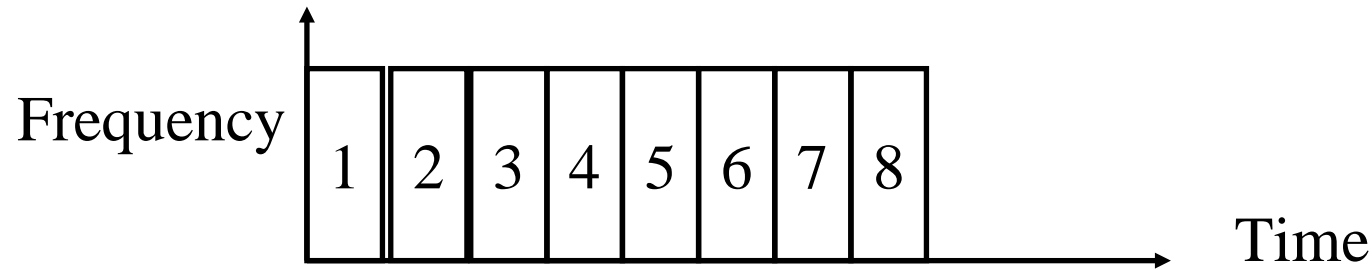

## ❑ Frequency Division Multiplexing (FDM)

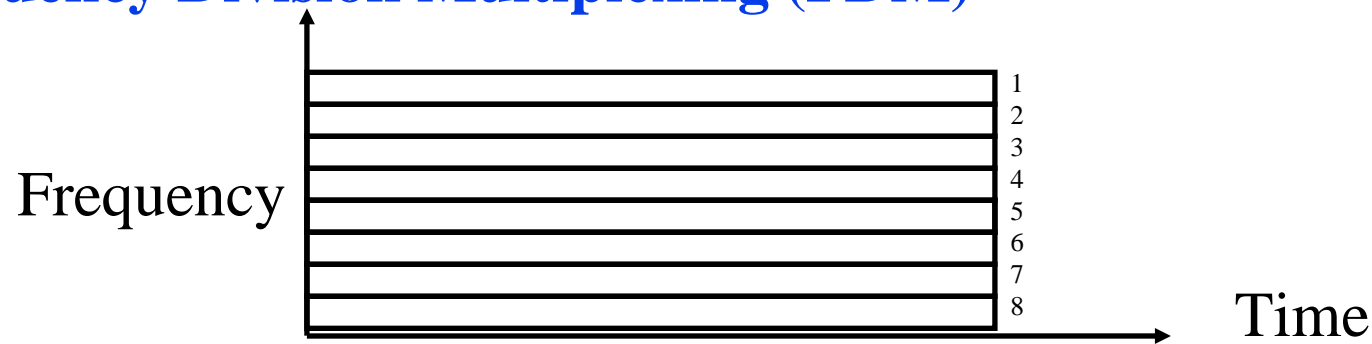

❑ Other multiplexing methods will be covered as needed.

## Student Questions

- ❑ Are multiplexing methods restricted by the medium (copper, wireless, etc.)?

*Yes, sometimes.*

- ❑ Are there any situations in which TDM is more advantageous than FDM? What are these scenarios?

*Bursty traffic is better handled by TDM.*

- ❑ How frequency division multiplexing applies to wired connection links. I didn't think copper could have a frequency band.

*Copper has a frequency band.*

- ❑ With TDM, how small can divisions of time get? Would they be on the scale of seconds, fractions of seconds?

*Milliseconds*

- ❑ My cellular service tends to slow down the density and the number of people. Is this due to cellular devices using FDM, where the network is partitioned into too many frequencies to the extent that each one is stretched too thin to offer quality network access?

*Overloading in TDM/FDM can slow the service.*



# Multiplexing

How can multiple users share a link?

## ❑ Time Division Multiplexing (TDM)

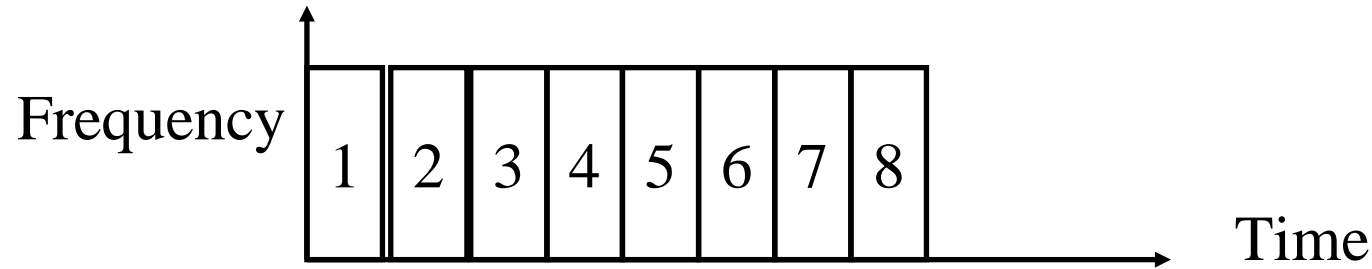

## ❑ Frequency Division Multiplexing (FDM)

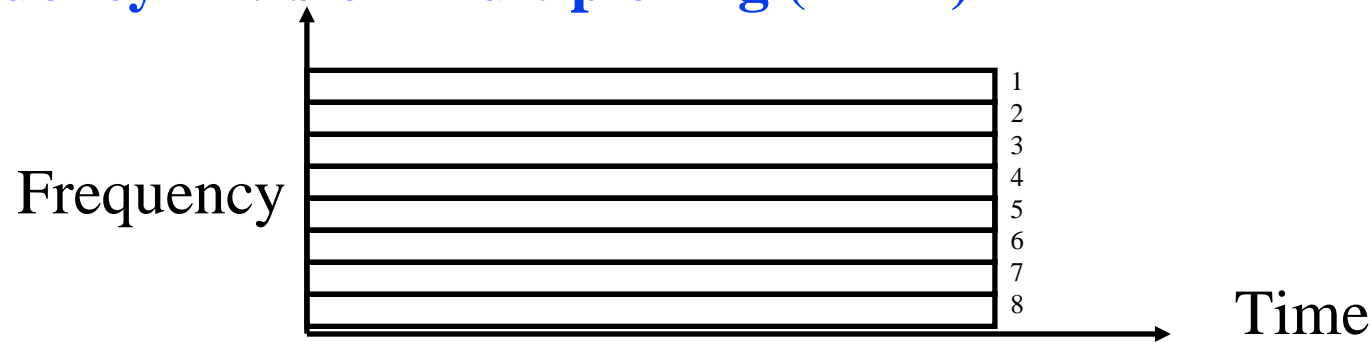

❑ Other multiplexing methods will be covered as needed.

## Student Questions

- ❑ When is FDM better than TDM?  
*To be discussed in Chapter 7.*
- ❑ What is the advantage of having the entire frequency band in TDM? Is the bandwidth higher during your allocated period?

*Yes.*

- ❑ How do bandwidth and signal interference limitations influence the choice between TDM and FDM in various communication networks?

*To be discussed in Chapter 7.*

- 
- ❑ Can you explain multiplexing further?

*Sharing a single resource is called multiplexing.*



# Multiplexing

How can multiple users share a link?

## ❑ Time Division Multiplexing (TDM)

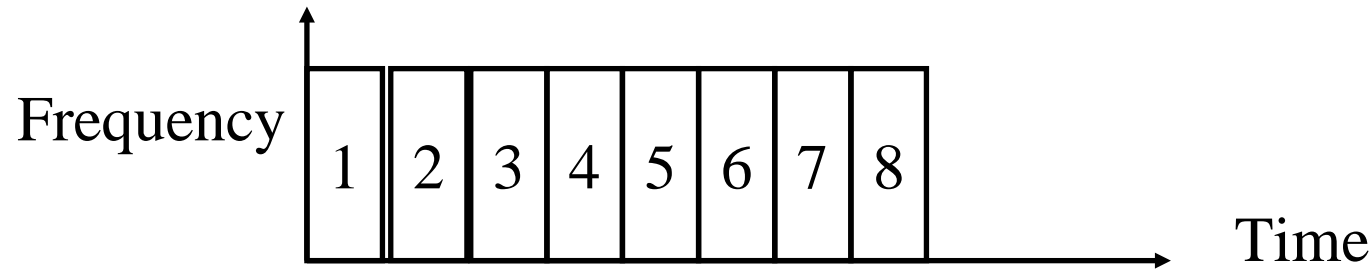

## ❑ Frequency Division Multiplexing (FDM)

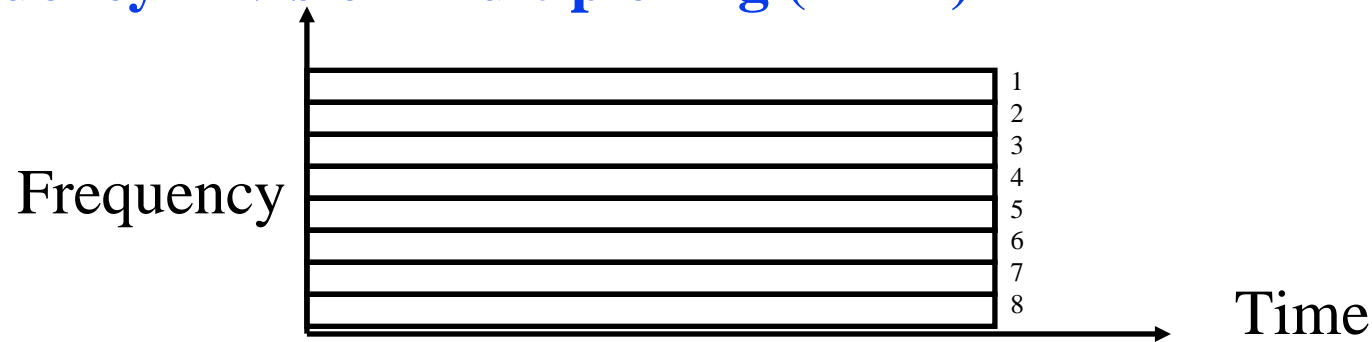

❑ Other multiplexing methods will be covered as needed.

## Student Questions

- ❑ How many data transfers are we scheduling per minute in modern networks?

*A few milliseconds or nanoseconds per transmission.*

- ❑ What are the cons of FDM?  
*Sometimes, it may be impossible or easy to divide frequency.*

- ❑ Is there a limit to how much the frequencies can be broken up before they are no longer distinct enough to function properly?

*Yes. This applies to TDM also.*



# Multiplexing

How can multiple users share a link?

## ❑ Time Division Multiplexing (TDM)

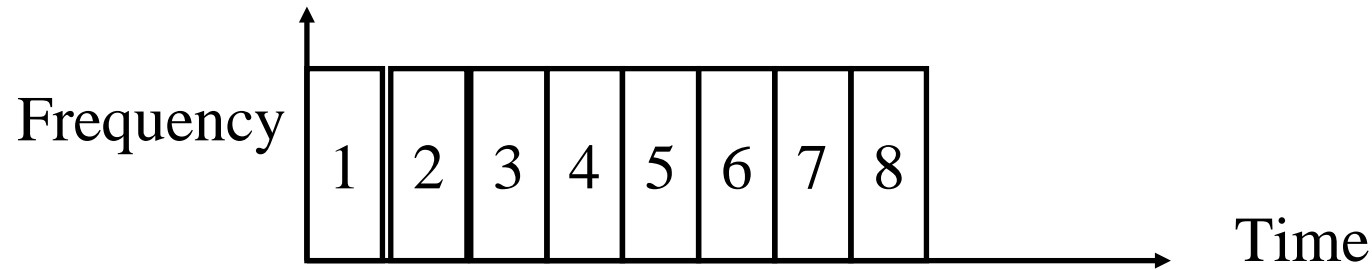

## ❑ Frequency Division Multiplexing (FDM)

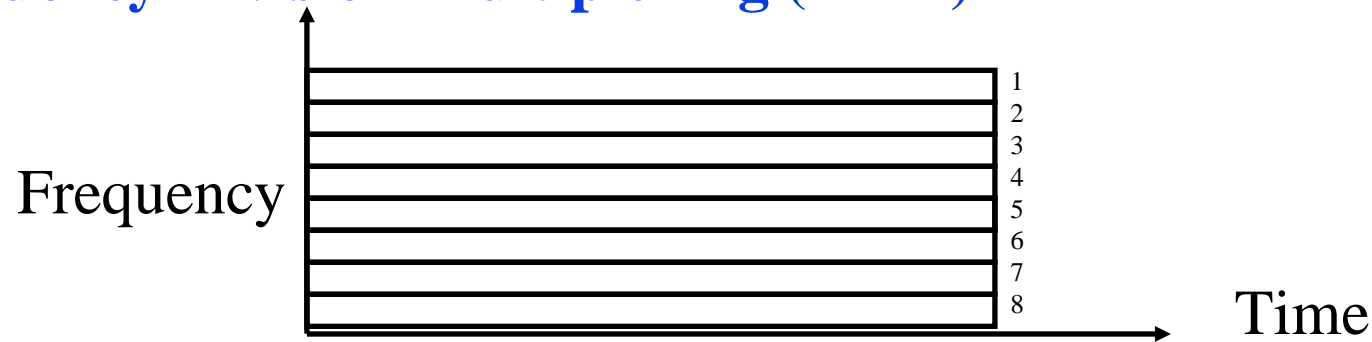

❑ Other multiplexing methods will be covered as needed.

## Student Questions

- ❑ Can you give me an example of when FDM is used?

*Bluetooth*

- ❑ How does TDM work for receiver devices in practice?

*They may keep track of time to fetch information at specific points, or they receive all information and extract the relevant pieces.*

# Types of Networks (Cont)

- ❑ **Local Area Networks (LAN):** 0-2 km, Single Ownership
- Metropolitan Area Networks (MAN)** 2-50 km,
- Wide Area Networks (WAN)** 50+ km
  - Originally LAN/MAN/WAN technologies were different
  - Now they are all the same
- ❑ **Telecom Networks:**
  - **Access:** Between the subscriber and the service provider
  - **Metro:** Covering a city
  - **Core:** Between cities

## Student Questions

- ❑ Why did LAN, MAN, and WAN become the same?

*We could design technologies that work at all distances.*

- ❑ Why are the telecom networks between cities called cores? *Terminology.*
- ❑ Is MAN still in use these days?  
*Yes, 4G and 5G are MAN.*
- ❑ When you say it is now all the same for LAN, MAN, and WAN, do you mean their functionalities or their technologies?

*Technology*

- ❑ How are the technologies used for LAN/MAN/WAN different from each other?

*Different distances require different protocols. Broadcast good only for small areas.*

- ❑ Why did LAN, MAN, and WAN become the same?

*We could design technologies that work at all distances.*

- ❑ Why are the telecom networks between cities called cores? *Terminology.*
- ❑ Is MAN still in use these days?  
*Yes, 4G and 5G are MAN.*



# Types of Networks (Cont)

- ❑ **Local Area Networks (LAN):** 0-2 km, Single Ownership
- Metropolitan Area Networks (MAN)** 2-50 km,
- Wide Area Networks (WAN)** 50+ km
  - Originally LAN/MAN/WAN technologies were different
  - Now they are all the same
- ❑ **Telecom Networks:**
  - **Access:** Between the subscriber and the service provider
  - **Metro:** Covering a city
  - **Core:** Between cities

## Student Questions

- ❑ How are LAN, MAN, and WAN technologies the same now?

*Ethernet has been extended to meet all requirements.*

---

- ❑ If LAN, MAN, and WAN become the same, why must we distinguish them?

*There are other differences between them.*

- ❑ Is there a limit to the number of packets that can be sent on a path, and if so, what is it?

*Each wire has a limit of bits/second.*

- ❑ For home networks, can you change whether your Wi-Fi is Point to point or star if you wish?

*No.*

---

- ❑ Do LAN, MAN, and WAN directly correspond to access, metro, and core networks?

*Not necessarily. LAN/MAN/WAN is related to distance. Access/ Metro/ Core is related to functions.*

# Structure of the Internet

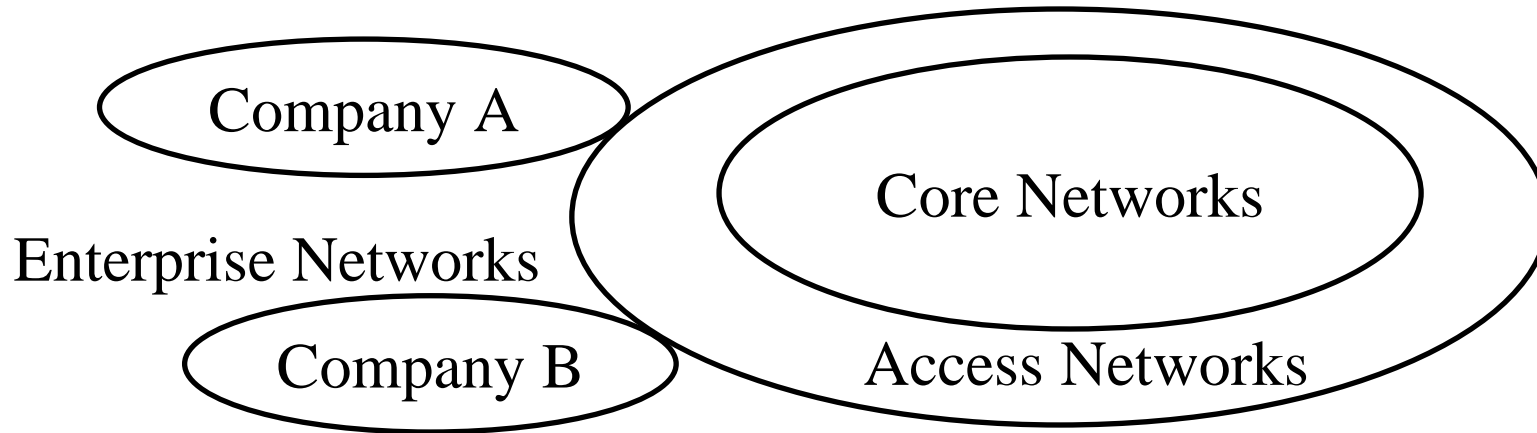

- ❑ Enterprise/Home Networks: **Stub** Networks.  
Privately owned ⇒ Not owned by ISP  
e.g., WUSTL network: Ethernet and WiFi
- ❑ **Access** Network: Enterprise/Users to ISP (in the city)  
WiFi, 3G/4G, DSL
- ❑ **Core** Network: ISP's network (between city): Optical Fiber

## Student Questions

- ❑ Why this diagram depicts core networks as a subset of access networks?  
*This is not a Venn diagram.*
- ❑ Why the access networks circle is bigger than the core networks.

*Access is on the edges of the core. Access connects to customers and is everywhere.*

*The airplanes owned by FedEx/ Amazon/UPS are their core transports.*

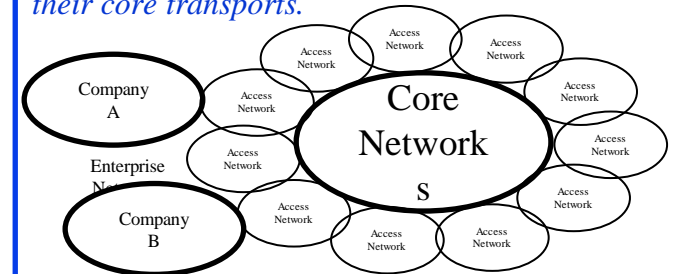

- ❑ What are stub networks?  
*They don't allow other companies' packets to go through.*
- ❑ Does Core Network mean only between networks of one ISP?

*No. A core can connect multiple ISPs.*

# Structure of the Internet

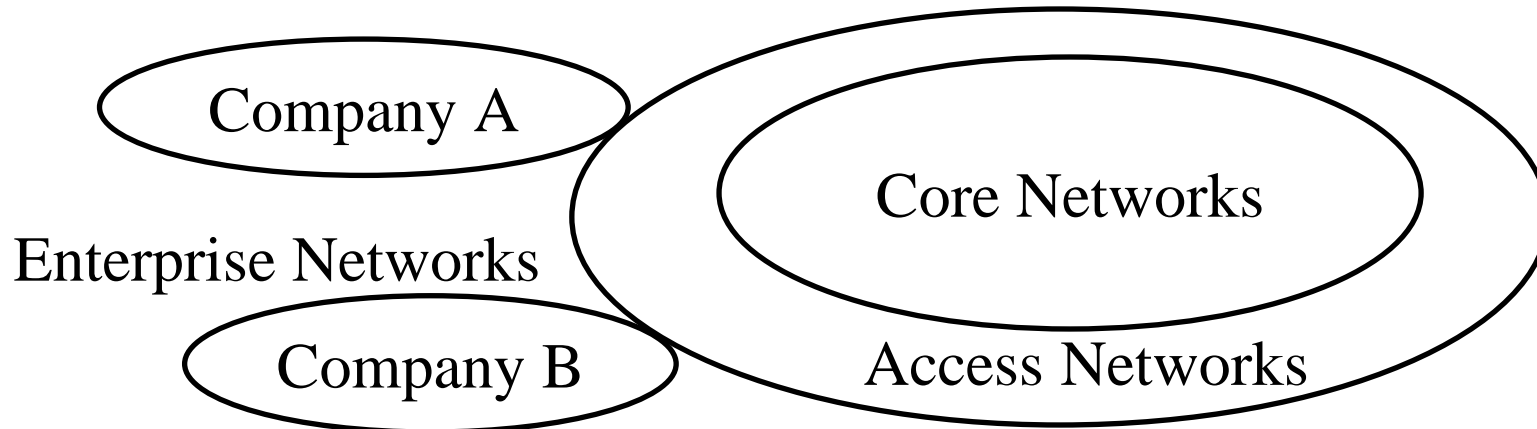

- ❑ Enterprise/Home Networks: **Stub** Networks. Privately owned ⇒ Not owned by ISP  
e.g., WUSTL network: Ethernet and WiFi
- ❑ **Access** Network: Enterprise/Users to ISP (in the city)  
WiFi, 3G/4G, DSL
- ❑ **Core** Network: ISP's network (between city): Optical Fiber

## Student Questions

- ❑ Since stub networks are not owned by ISP, how do they provide Internet? As I remember, ISP provides Internet. Does this mean stub networks are ISP themselves?

*No. Stub networks are clients. They do not provide Internet to anyone outside. For example, WUSTL is a stub network.*

- ❑ Do private enterprise networks with no connection to the larger internet exist? If so, what is their primary use?

*WUSTL is a private enterprise network.*

- ❑ Could you explain this diagram? What does it mean that companies A and B are adjacent to access networks?

*Access = Carrier to the customer*

- ❑ Is it right to say that 'enterprise networks are connected to the core network via access network'?

*Core and access are differentiated by the carrier not by the customer. So the customers really connect to the access network.*

- ❑ Can Stub networks be categorized as ISP but for internal users?

*No*

# Structure of the Internet

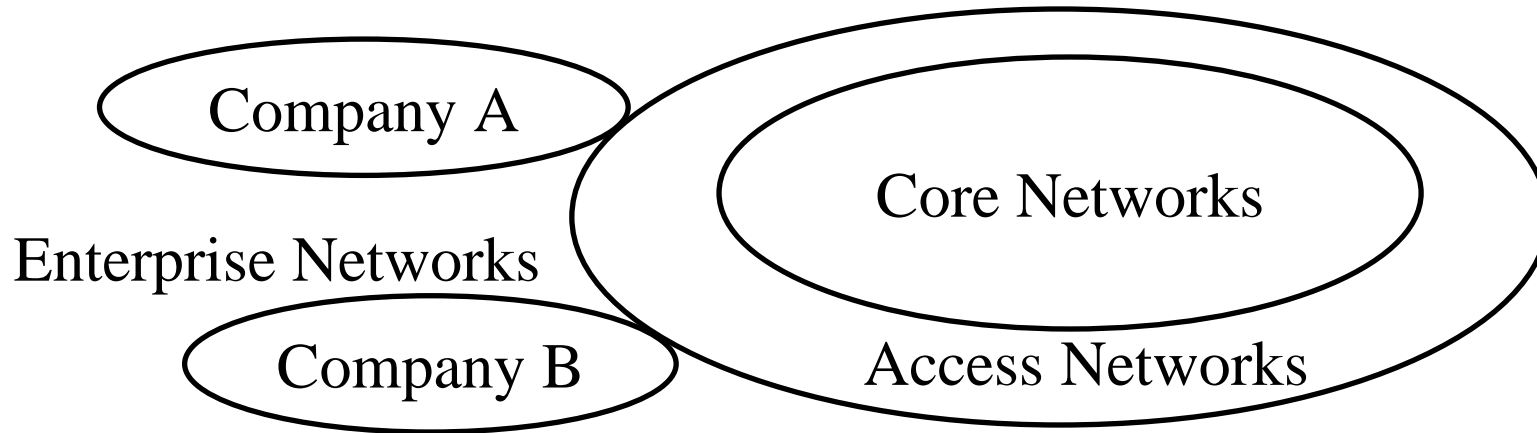

- ❑ Enterprise/Home Networks: **Stub** Networks. Privately owned  $\Rightarrow$  Not owned by ISP  
e.g., WUSTL network: Ethernet and WiFi
- ❑ **Access** Network: Enterprise/Users to ISP (in the city)  
WiFi, 3G/4G, DSL
- ❑ **Core** Network: ISP's network (between city): Optical Fiber

## Student Questions

- ❑ Chapter 1, page 12. The textbook defines an access network as: "the network that physically connects an end system to the first router (also known as the "edge router") on a path from the end system to any other distant end system." However, on the graph below this definition, two routers are on the path from the Home network to the local ISP. Why is the second router considered the "edge router"?

*The first router is part of the home network.  
ISP starts with the edge router.*

- ❑ What kind of networks are Amazon VPCs (Virtual Private Clouds)? What are the advantages of having a logically isolated network of servers (other than security)?

*Cloud computing will be discussed in the next course.*

- ❑ If I use my phone for course registration, then the connected path is: phone  $\leftrightarrow$  5G/wifi Access network  $\leftrightarrow$  ISP's core network  $\leftrightarrow$  Access Network  $\leftrightarrow$  WUSTL Stub network.

*Correct.*

# Structure of the Internet

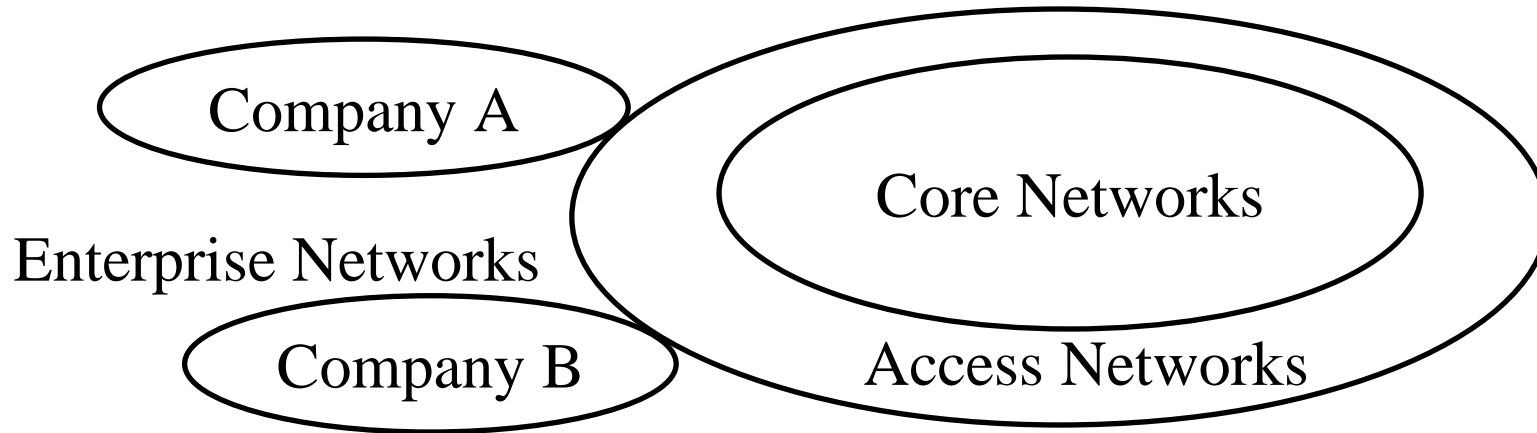

- ❑ Enterprise/Home Networks: **Stub** Networks.  
Privately owned ⇒ Not owned by ISP  
e.g., WUSTL network: Ethernet and WiFi
- ❑ **Access** Network: Enterprise/Users to ISP (in the city)  
WiFi, 3G/4G, DSL
- ❑ **Core** Network: ISP's network (between city): Optical Fiber

## Student Questions

- ❑ How does Starlink factor into this; has it drastically improved the speed and throughput of satellite internet access?

*Starlink uses low-earth-orbiting (LEO) satellites to reduce the delay.*

- ❑ What are the main components of the Internet's structure as depicted in the slide, and how do stub networks differ from access networks?

*Stub networks are private, while access networks are public.*

# Types of ISPs

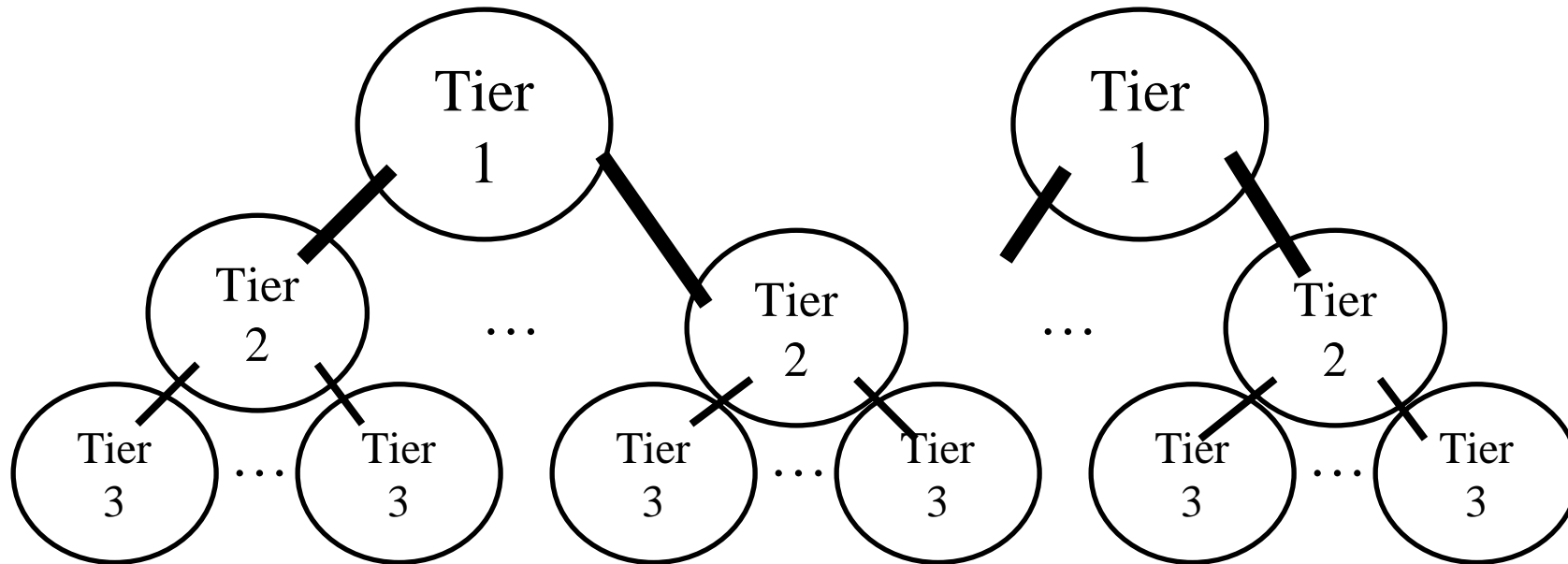

- ❑ **Tier 1:** Global or National, e.g., AT&T, Verizon, ...
- ❑ **Tier 2:** Regional
- ❑ **Tier 3:** Local

## Student Questions

- ❑ At what level/tier are tier 1 ISPs usually connected to each other?  
*There are no higher Tier ISPs. A Tier 1 network might be connected to another Tier 1 network through a third Tier 1 network.*
- ❑ Would you elaborate on practical differences between coaxial vs. twisted pair (for example, relative transmission rates) and on practical differences between wireless vs. microwave?  
❑ Is all wireless microwave?  
*No. Please wait till Module 7.*
- ❑ Is the main upside to unguided transmission media the ability to have the end system be more mobile?  
*Sometimes wireless is used between towers to reduce cabling cost.*
- ❑ When you refer to just "fiber", are you referencing optic fiber? *Yes*
- ❑ Who decides which ISP belongs to what tier?  
*Higher tiers provide services to lower tiers.*
- ❑ Could Tier 2 or 3 use the infrastructure of Tier 1's network? *Yes.*

# Types of ISPs

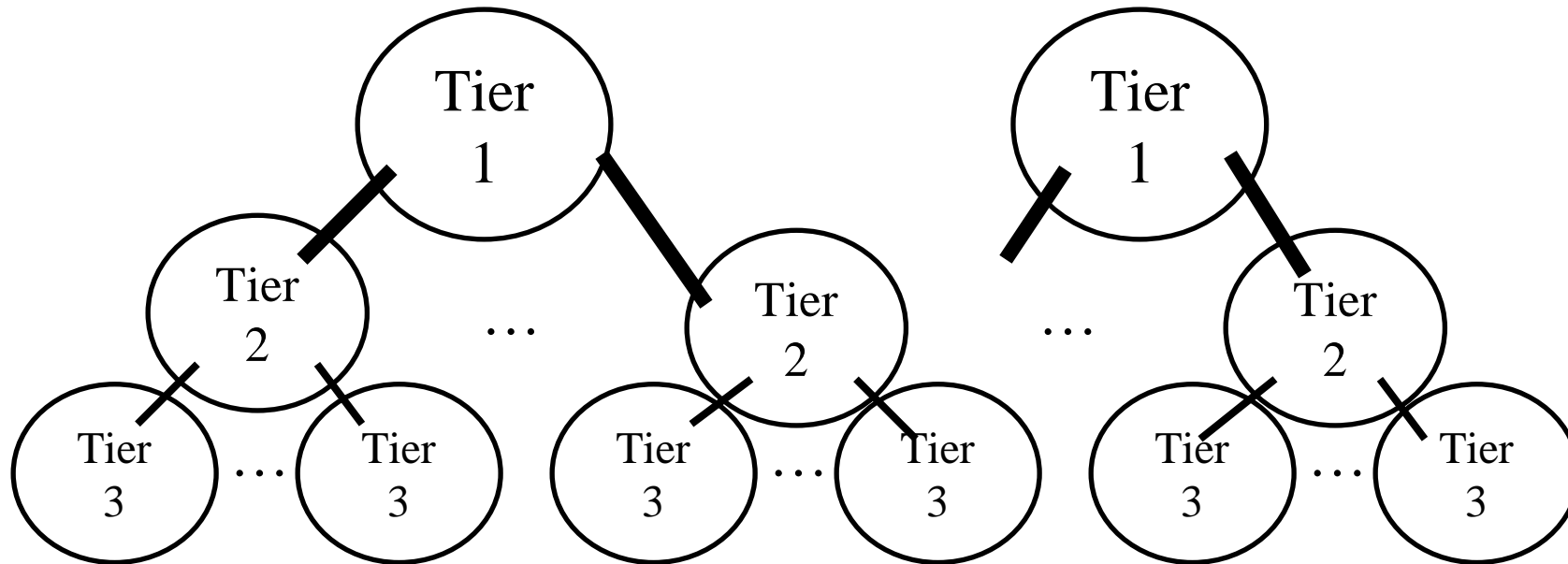

- ❑ **Tier 1:** Global or National, e.g., AT&T, Verizon, ...
- ❑ **Tier 2:** Regional
- ❑ **Tier 3:** Local

## Student Questions

- ❑ Do Tier 1 ISPs always cover regions that Tier 2/3 ISPs cover? *Not necessary.*
- ❑ Is the connection between Tier 1 and Tier 2 or the connection between Tier 2 and Tier 3 core networks? *Both*
- ❑ What is the relationship between Tier and an ISP Network? *Tier is a class of ISPs.*
- ❑ What is the relationship between ISP in different tiers? Do they provide the same service, or do they divide their work?

*Their distances, speeds, and customers are different*

- ❑ Does the regional ISP use tier 1 ISP to connect with other regional ISPs? *Yes.*
- ❑ Do the different tiers of networks share the same speed?

*Tier 1 has more traffic than Tier 2. Tier 1 has a higher speed than Tier 2.*

- ❑ Are there connections between networks of the same tier, or do they always communicate via a higher-tier network?

*No specific requirements. These are business arrangements.*

# Types of ISPs

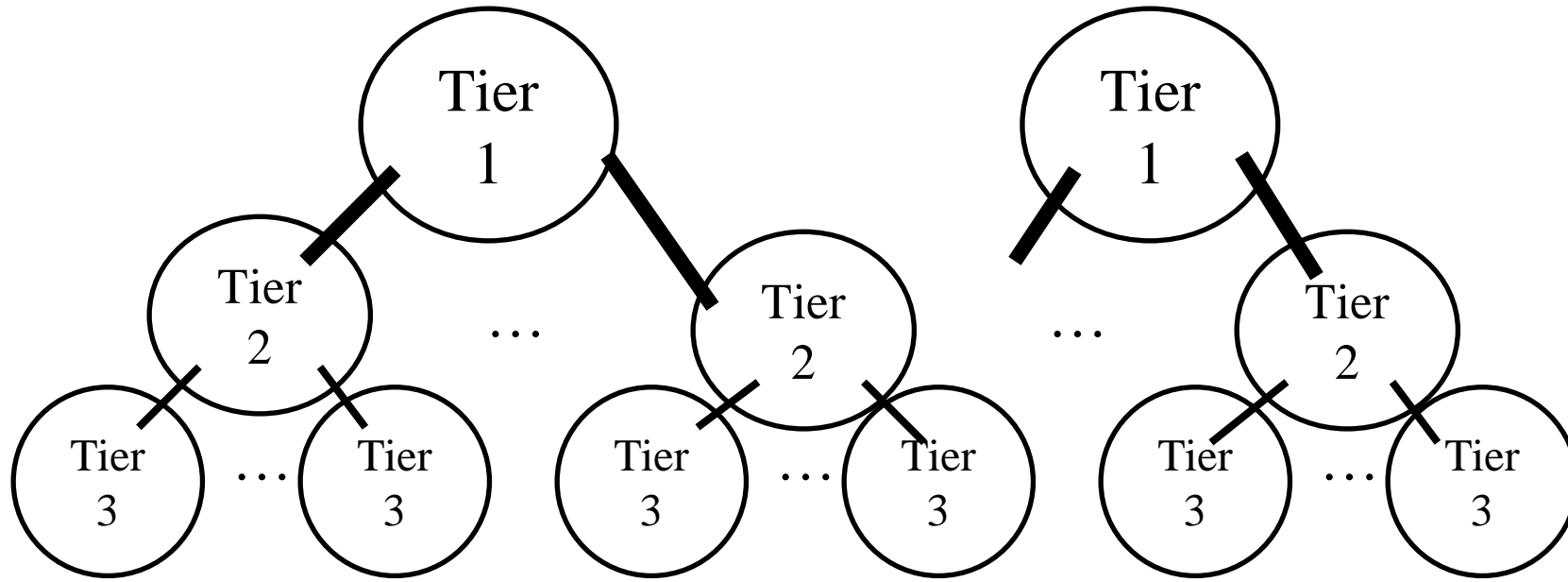

## Student Questions

- ❑ How do international phone calls from a network perspective? It seems beyond Tier 1 networks.

*Tier 1 could be international.*

- ❑ Do the global companies connect the Tier 2 ones?

*Yes. Tiers could be International, National, and Local, but not necessary.*

- ❑ Can a Tier 2 ISP directly provide international connectivity without relying on Tier 1 ISPs?

*Yes, it would be called Tier 1.*



# Transmission Media

## □ Guided:

- Twisted Pair
- Coaxial cable
- Optical fiber

## □ Unguided:

- Microwave
- Satellite
- Wireless

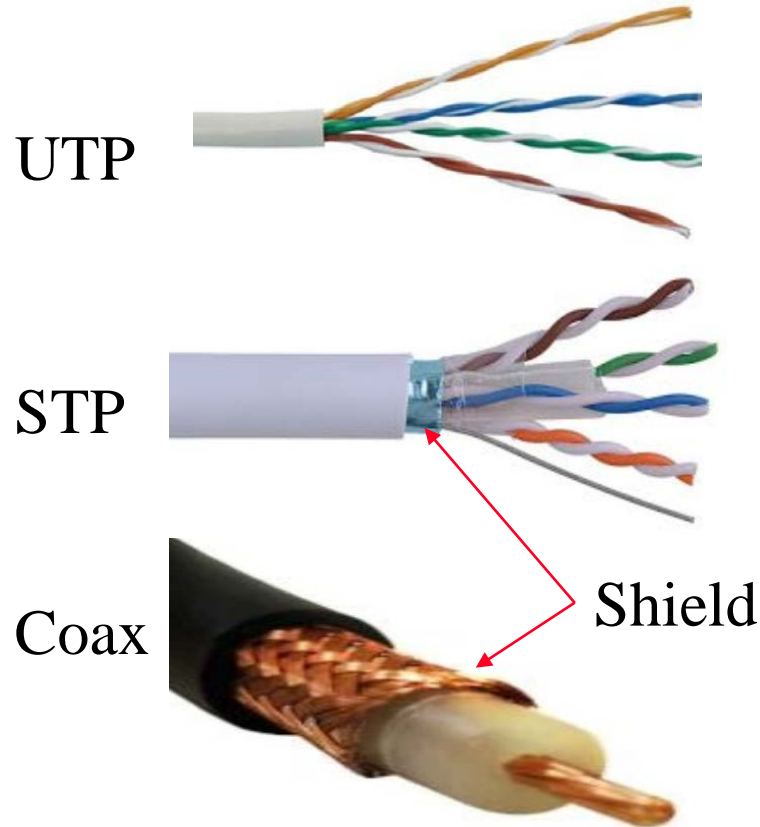

## Student Questions

- It was mentioned in the lecture that a Coaxial cable is an example of an STP (Shielded Twisted Pair). Googling the difference seems to indicate that "Twisted Pair Cables" are distinct from "Coaxial Cables." Can you clarify the relationship between Twisted Pair vs. Coaxial?

*The coaxial cable is shielded but not twisted because it has only one wire. STP has many pairs, and each pair is twisted. A metallic shield protects all pairs.*

- Is microwave how all wireless connections are made? *Most.*
- Is there such a thing as an unguided wired transmission medium? *Antenna*
- What is a coaxial cable?  
*Cable from the cable company*
- Can a communication bus be either guided or unguided?

*Busses are usually guided.*

- Are there any strong advantages of using guided over unguided and vice versa?

*Yes. Security.*

# Transmission Media

## □ Guided:

- Twisted Pair
- Coaxial cable
- Optical fiber

## □ Unguided:

- Microwave
- Satellite
- Wireless

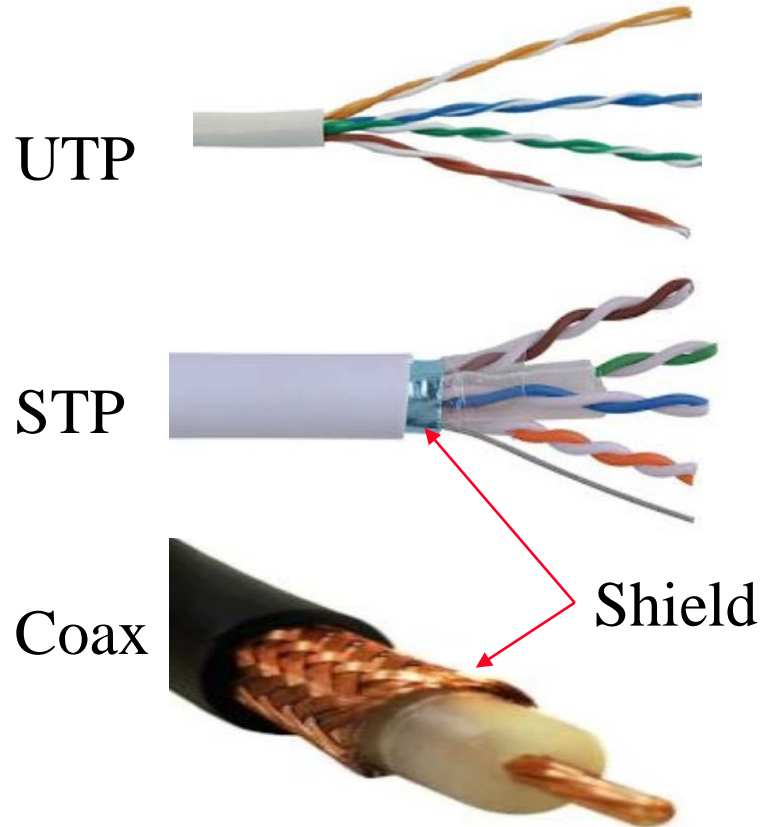

## Student Questions

- Why can't we know where signals go in unguided media? Does it have to do with frequency?

*We know. We can sense it.*

- Why are coax cables single-wire?  
*They are thick. If you use multiple wires, you have to twist them, which we call STP.*

- How is noise dealt with for wireless transmission media?

*To be covered in Chapter 7.*

- What exactly is Coax? How is it different from STP?

*Coax = Single thick wire usually used by video providers*

*STP = Needs at least two wires to twist*

- If the microwave is undirected, why do trading companies send data between New York and Chicago via disc relays?

*Microwave = wireless*

*Companies use whatever they can.*

*Microsecond delays on trades can make big difference.*

- How does guided transmission offer more security than encrypted unguided?

*Encryption can be broken.*

# Transmission Media

## □ Guided:

- Twisted Pair
- Coaxial cable
- Optical fiber

## □ Unguided:

- Microwave
- Satellite
- Wireless

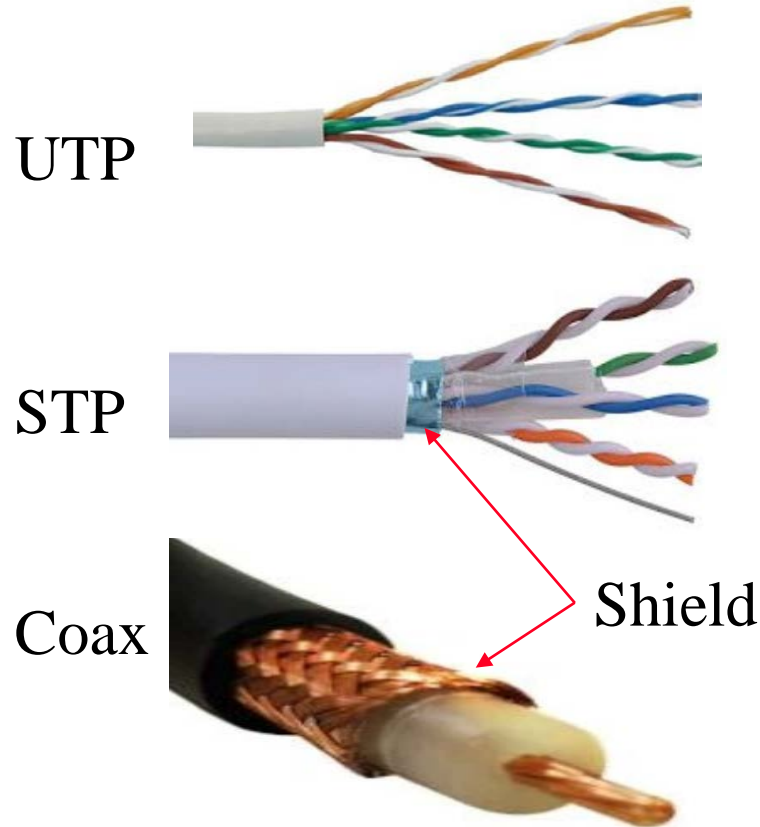

## Student Questions

- Is guided generally faster than unguided? Also, would unguided wireless be possible to implement in networks and what would be the pros and cons of doing so?

*Guided causes less interference. Wireless is usually unguided.*

- Which are the types of cables that are laid underneath the ocean?

*These would be STP or UTP. Shield is designed to withstand salt.*

- 
- How does a shielded twisted pair (STP) differ from an unshielded twisted pair (UTP) in terms of protection against interference?

*Discussed in the next few slides.*

# Transmission Media

## □ Guided:

- Twisted Pair
- Coaxial cable
- Optical fiber

## □ Unguided:

- Microwave
- Satellite
- Wireless

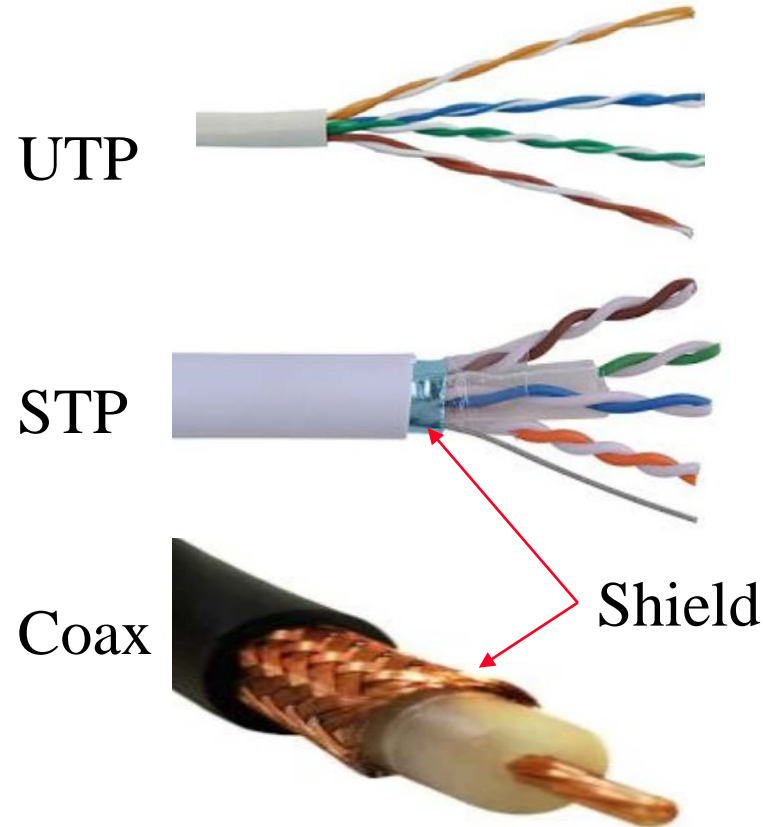

## Student Questions

- Is coaxial cable the same thing as cable?

*No. A cable can be of many types. Coaxial is one of the types.*

- Did you say guided could be wireless?

*No. Wired communication is generally guided. Wireless is generally unguided. However, there are exceptions to every statement.*

# Twisted Pair (TP)

- Separately insulated
- Twisted together
- Often "bundled" into cables
- Usually installed in building during construction

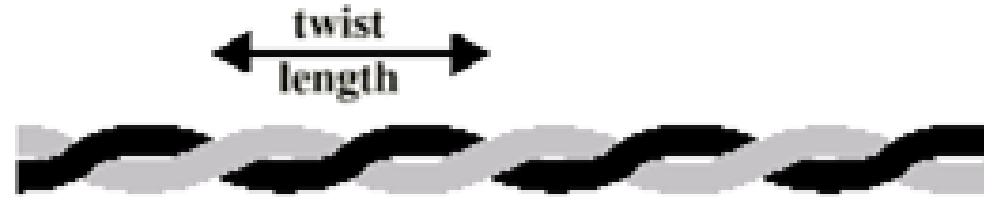

(a) Twisted pair

- ❑ Twists decrease the cross-talk
- ❑ Neighboring pairs have different twist length
- ❑ Most of telephone and network wiring in homes and offices is TP.

## Student Questions

- ❑ What is the mechanism behind twisted pairs can reducing cross-talk? Why do neighboring pairs need to have different twist lengths? Did there exist a limit speed for twisted pairs?

*Part of Electrical Engineering Communications course.*

- ❑ Why do twisted pairs help to reduce interference?

*Canceling electromagnetic interference.*

- ❑ Would two untwisted wires running parallel interfere with each other? Also, would wire pairs twisted at the same twist length interfere with each other?

*Yes. Yes. More similarity=> More interference.*

- ❑ In a twisted pair, is one the main channel and the other serves as shielding, or are both interpreted at the destination?

*Both.*

- ❑ How does TP lower the interference or cross-talk?

*Interference cancels out*

- ❑ How do the differing twist lengths play into things?

*More twists are better.*

# Twisted Pair (TP)

- Separately insulated
- Twisted together
- Often "bundled" into cables
- Usually installed in building during construction

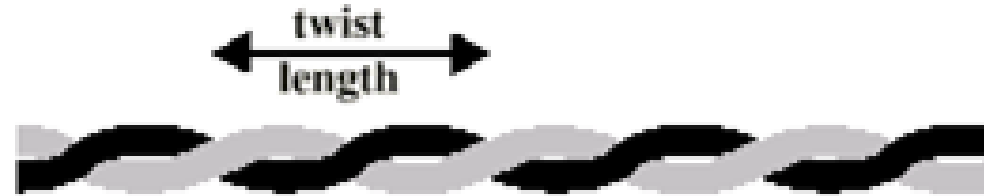

(a) Twisted pair

- ❑ Twists decrease the cross-talk
- ❑ Neighboring pairs have different twist length
- ❑ Most of telephone and network wiring in homes and offices is TP.

## Student Questions

- ❑ What are the negatives to having a maximum twist on wires? If twisting helps to mitigate any outside interference, why not twist as much as possible?

*The wire may break or be difficult to bend/handle.*

- ❑ Are the multiple wires in phone or laptop charging and data cables considered TP?

*Phone wire may or may not be twisted. Network wires are all twisted. Charging cables without data capability are not twisted.*

- ❑ Why would we need more or fewer twisted pairs?

*More pairs ⇒ More data can be sent ⇒ Higher speed.*

- ❑ Why are there four pairs of twisted pairs in a cable? What not 3 2 1?

*10 Mbps Ethernet had 2 pairs. 100 Mbps and up requires 4 pairs.*

- ❑ How many twists are optimal for the most minor interference

*The more, the better.*

# Twisted Pair (TP)

- Separately insulated
- Twisted together
- Often "bundled" into cables
- Usually installed in building during construction

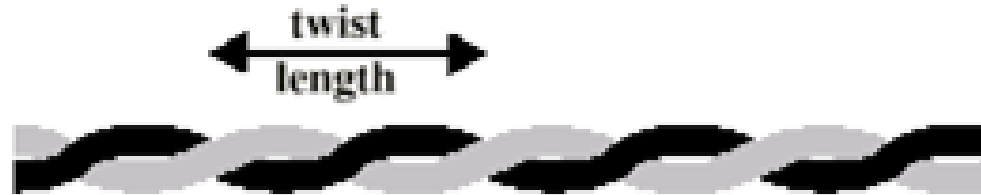

(a) Twisted pair

- ❑ Twists decrease the cross-talk
- ❑ Neighboring pairs have different twist length
- ❑ Most of telephone and network wiring in homes and offices is TP.

## Student Questions

- ❑ Can you iterate on how exactly the twisted pairs cancel out interference?

*This is taught in Communication courses in ESE.*

- ❑ TP decreases cross talk? Why is there any cross-talk at all? wires are separately insulated?

*Insulation prevents only direct current (DC). High-frequency AC can leak out. That's how wireless works.*

- ❑ Is twist length the number of twists per some unit of distance?

*Twist Length = Distance/# of twists*

- ❑ Why is it only in pairs?  
*You can also use just one wire, e.g., in a coaxial cable.*



# Shielded and Unshielded TP

## ❑ Shielded Twisted Pair (STP)

- Metal braid or sheathing that reduces :
- More expensive
- Harder to handle (thick, heavy)
- Used in token rings

## ❑ Unshielded Twisted Pair (UTP)

- Ordinary telephone wire
- Cheap, Flexible
  - ⇒ Easiest to install
- No shielding
  - ⇒ Suffers from external interference
- Used in Telephone and Ethernet

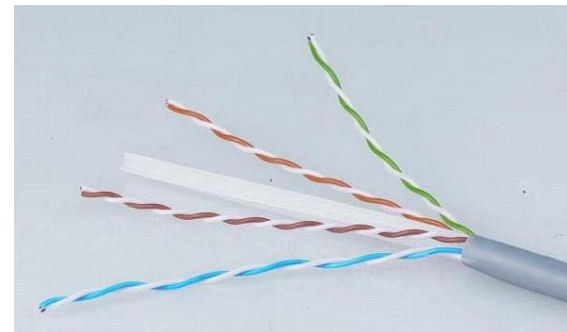

## Student Questions

- ❑ How specifically is infrared light used to input in optical cables?

*Lasers are used to inject light into a hair-thin optical fiber.*

- ❑ What are token rings?

*Competed with but obsoleted by Ethernet.*

- ❑ Are UTPs links? If so, does UTP use FDM or TDM? *You can use either one.*
- ❑ Is twisted length the standard to differentiate those categories?

*One of many parameters.*

- ❑ How to distinguish between a telephone wire and an Ethernet wire?

*Telephone=2 or 4 wires*

*Ethernet=8 wires*

- ❑ Since Ethernet uses UTP, and telephones use UTP too, can we use the telephone wire as an Ethernet cable?

*No. You can use an Ethernet cable as a phone wire but not the other way around. Ethernet requires higher performance.*

- ❑ Are there Cat 1 and Cat 2? *No longer.*
- ❑ Are USB cables twisted pairs?

*Of the four wires (two pairs), one is data pair, and it is twisted.*

# Shielded and Unshielded TP

## ❑ Shielded Twisted Pair (STP)

- Metal braid or sheathing that reduces interference
- More expensive
- Harder to handle (thick, heavy)
- Used in token rings



## ❑ Unshielded Twisted Pair (UTP)

- Ordinary telephone wire
- Cheap, Flexible
  - ⇒ Easiest to install
- No shielding
  - ⇒ Suffers from external interference
- Used in Telephone and Ethernet

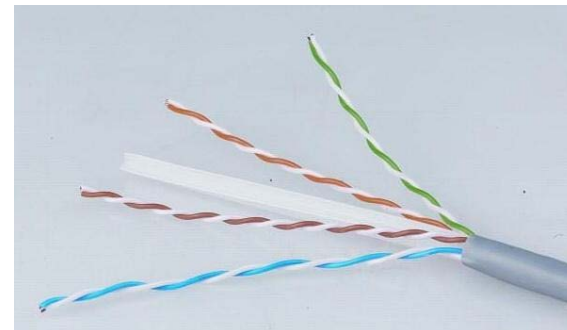

## Student Questions

- ❑ How does the metal braid or sheathing of STP reduce interference?

*Braid catches the interfering signal.*

- ❑ Is token rings still being used today?

*No.*

- ❑ When is STP used besides for token rings?

*I am not aware.*

- ❑ Which type is used for TV, if any?

*Coax.*

- ❑ Are there no Shielded Twisted Pairs (STP) at all?

*It is used in high-security, high-interference, or high-speed environments.*

# Shielded and Unshielded TP

## ❑ Shielded Twisted Pair (STP)

- Metal braid or sheathing that reduces interference
- More expensive
- Harder to handle (thick, heavy)
- Used in token rings

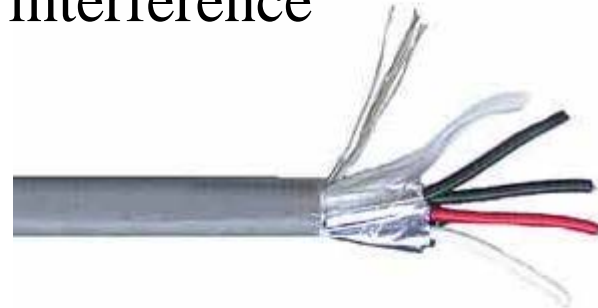

## ❑ Unshielded Twisted Pair (UTP)

- Ordinary telephone wire
- Cheap, Flexible
  - ⇒ Easiest to install
- No shielding
  - ⇒ Suffers from external interference
- Used in Telephone and Ethernet

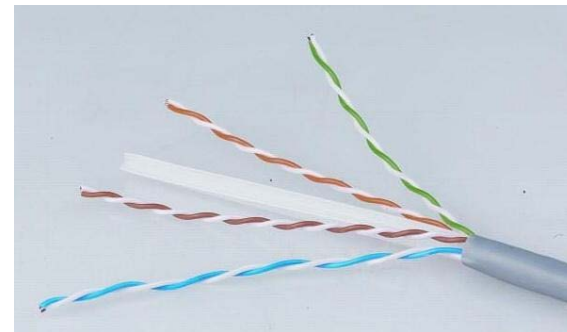

## Student Questions

- ❑ Was Point-to-point chosen to replace Token Ring, or is there more to know about network types?

*Rings also use point-to-point links. Bus/star topology is the opposite of ring topology. Token rings died because of cost/complexity compared to Ethernet.*

# UTP Categories

## ❑ Cat 3

- Up to 16MHz
- Voice grade found in most offices
- Twist length of 7.5 cm to 10 cm

## ❑ Cat 4

- Up to 20 MHz. Not used much in practice.

## ❑ Cat 5

- Up to 100MHz
- Used in 10 Mbps and 100 Mbps Ethernet
- Twist length 0.6 cm to 0.85 cm

## ❑ Cat 5E (Enhanced to 100 MHz)

## ❑ Cat 6 (250 MHz), Cat 6A (500 MHz)

## ❑ Cat 7 (700 MHz), CAT 7A (1000 MHz)

## ❑ Cat 8 (2000 MHz), ...

Ref: [https://en.wikipedia.org/wiki/ISO/IEC\\_11801](https://en.wikipedia.org/wiki/ISO/IEC_11801)

Washington University in St. Louis

[http://www.cse.wustl.edu/~jain/cse473-25/i\\_1cni/](http://www.cse.wustl.edu/~jain/cse473-25/i_1cni/)

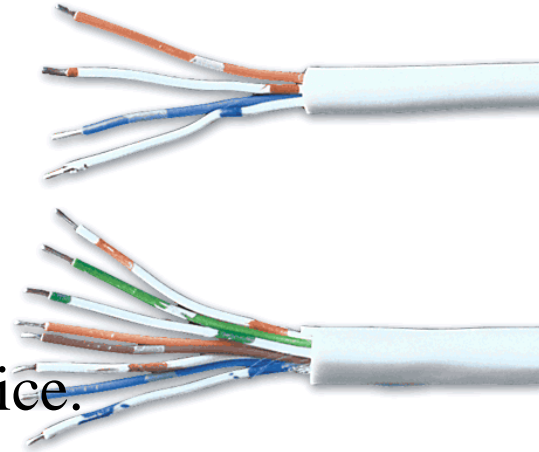

## Student Questions

- ❑ What is the number behind the Cat (Category) related to the frequency it can hold? *Class or quality.*
- ❑ When you say broadcast if we transmit too much data over the wire, do you mean that it will be leaked out and can be picked up by a 3rd party?

*Broadcast=Everyone can hear it.*

- ❑ Why does a shorter twisted length correspond to a higher transmission rate?

*Taught in ECE Communications courses.*

- ❑ Is our network speed bound by the slowest transmission media? If so, how can we detect the bottlenecks on our end?

*There are many ways to find the bottleneck.*

- ❑ Do different amounts of Hz of different UTP categories mean their ability to send those kinds of signals? Like from 10 MHz up to 100 MHz? And why more MHz means better UTP.

*More MHz = More bits/second*

- ❑ Does UTP with a larger category number have more TP pairs inside it?

*No. Thicker wires.*

©2025 Raj Jain

# UTP Categories

## ❑ Cat 3

- Up to 16MHz
- Voice grade found in most offices
- Twist length of 7.5 cm to 10 cm

## ❑ Cat 4

- Up to 20 MHz. Not used much in practice.

## ❑ Cat 5

- Up to 100MHz
- Used in 10 Mbps and 100 Mbps Ethernet
- Twist length 0.6 cm to 0.85 cm

## ❑ Cat 5E (Enhanced to 100 MHz)

## ❑ Cat 6 (250 MHz), Cat 6A (500 MHz)

## ❑ Cat 7 (700 MHz), CAT 7A (1000 MHz)

## ❑ Cat 8 (2000 MHz), ...

Ref: [https://en.wikipedia.org/wiki/ISO/IEC\\_11801](https://en.wikipedia.org/wiki/ISO/IEC_11801)

Washington University in St. Louis

[http://www.cse.wustl.edu/~jain/cse473-25/i\\_1cni/](http://www.cse.wustl.edu/~jain/cse473-25/i_1cni/)

©2025 Raj Jain

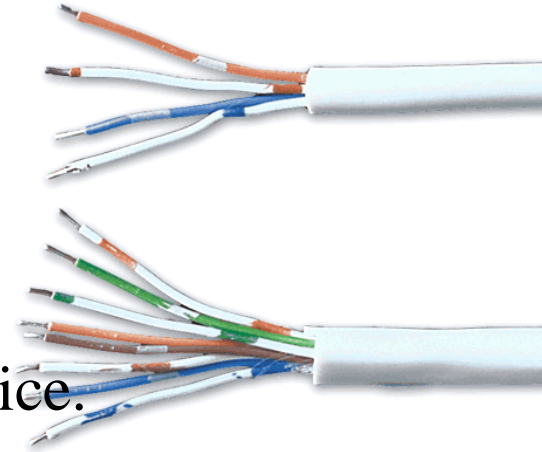

## Student Questions

- ❑ What exactly does the frequency of a wire indicate?
- It cuts off the signal of higher frequency.*
- ❑ Does the color of the Ethernet cable correspond to a specific category? *No.*
- ❑ Is there a mathematical scale to the categories assigned to UTP cables, or is it more arbitrary? *Yes. See MHz.*
- ❑ Why is there a gap between the release of each Cat version? For example, why would Cat 8 be used much later than Cat 3 if the only difference is the number of wire pairs?

*Higher Cats are more expensive, and there is no market if there is no need.*

- ❑ Why is Cat 4 not commonly used in practice?

*We use high-speed networks now.*



# UTP Categories

## ❑ Cat 3

- Up to 16MHz
- Voice grade found in most offices
- Twist length of 7.5 cm to 10 cm

## ❑ Cat 4

- Up to 20 MHz. Not used much in practice.

## ❑ Cat 5

- Up to 100MHz
- Used in 10 Mbps and 100 Mbps Ethernet
- Twist length 0.6 cm to 0.85 cm

## ❑ Cat 5E (Enhanced to 100 MHz)

## ❑ Cat 6 (250 MHz), Cat 6A (500 MHz)

## ❑ Cat 7 (700 MHz), CAT 7A (1000 MHz)

## ❑ Cat 8 (2000 MHz), ...

Ref: [https://en.wikipedia.org/wiki/ISO/IEC\\_11801](https://en.wikipedia.org/wiki/ISO/IEC_11801)

Washington University in St. Louis

[http://www.cse.wustl.edu/~jain/cse473-25/i\\_1cni/](http://www.cse.wustl.edu/~jain/cse473-25/i_1cni/)

©2025 Raj Jain

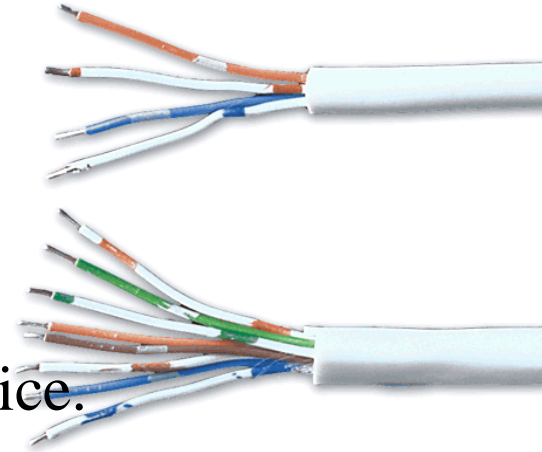

## Student Questions

- ❑ Does the twist length affect the maximum transmission length of the wire?

*Twist length affects interference which affects the transmission length.*

- ❑ At higher frequencies, a wire can transfer more bits/second. Why is the frequency different when the twist length is different?

*Higher frequencies leak out more than lower frequencies. So you can not transmit very high frequency with some wires.*

# Optical Fiber

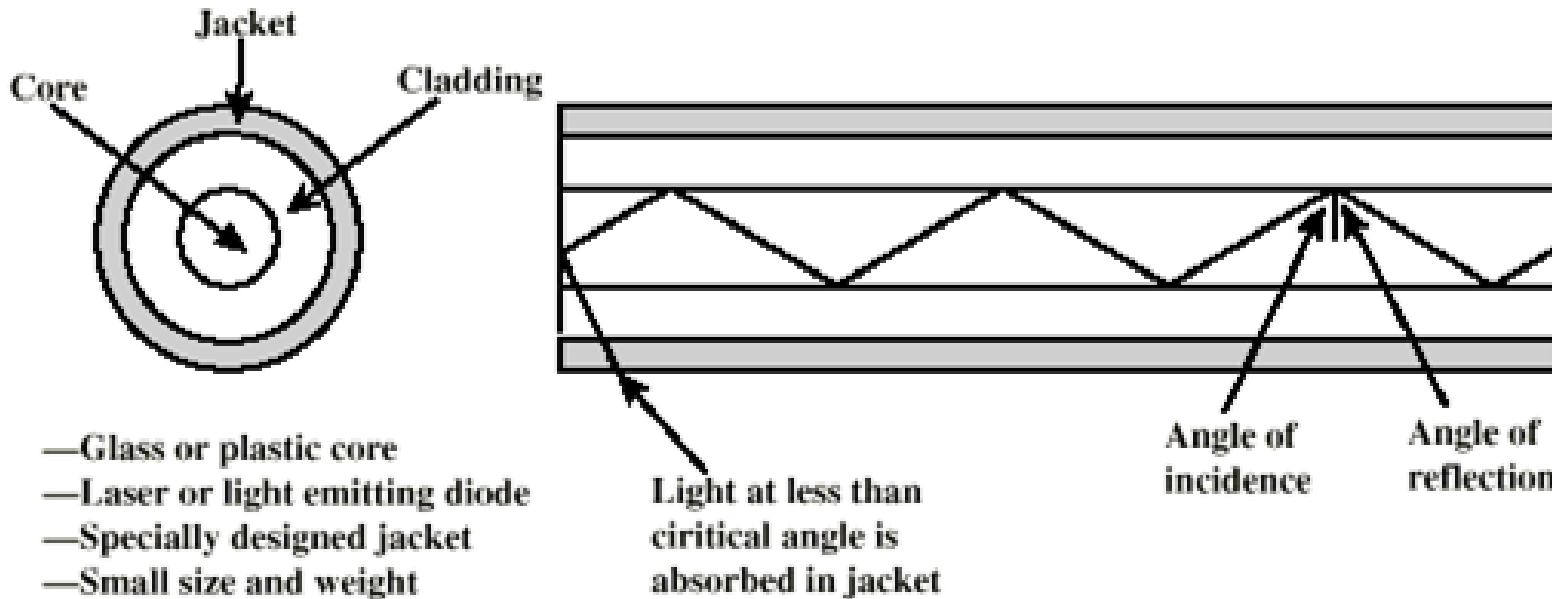

- ❑ A cylindrical mirror is formed by the cladding.
- ❑ The light wave propagates by continuous reflection in the fiber
- ❑ Not affected by external interference  $\Rightarrow$  low bit error rate
- ❑ Fiber is used in all long-haul or high-speed communication
- ❑ Infrared light is used in communication

## Student Questions

- ❑ Is infrared considered to be a subset of microwaves?  
*These are different frequencies. See Slide 18.*
- ❑ How much do we need to know about the spectrum? (like what range is radio)

*Yes.*

- ❑ Is it possible to use ultraviolet light or visible light for optical communication, as both of them have a shorter wavelength and thus seem to have a higher possible transmission rate?

*Yes. The properties of the signal are different, and so cost and applications are different.*

- ❑ How is it possible for light at less than critical angles to be absorbed in a jacket?

*Light can become heat.*

- ❑ How is the optical fiber cable able to send light signals even when the cable is bent? Wouldn't the bending of the cable distort the path of the light?

*No bends are like a mile-wide turn for nano-nano-meter waves.*

- ❑ Is cost the only benefit of copper over optical?

*Also, tools to connect copper are simpler.*



# Optical Fiber

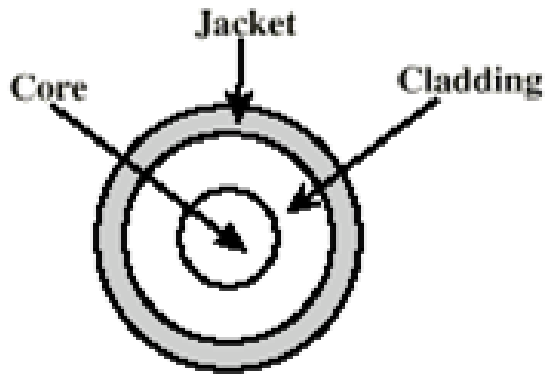

- Glass or plastic core
- Laser or light emitting diode
- Specially designed jacket
- Small size and weight

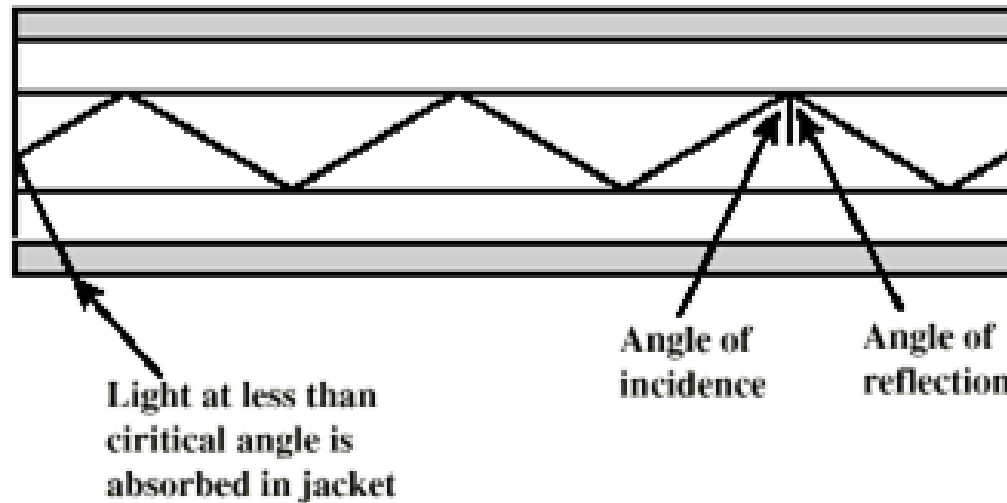

- ❑ A cylindrical mirror is formed by the cladding.
- ❑ The light wave propagates by continuous reflection in the fiber
- ❑ Not affected by external interference  $\Rightarrow$  low bit error rate
- ❑ Fiber is used in all long-haul or high-speed communication
- ❑ Infrared light is used in communication

## Student Questions

- ❑ Must the laser travel through optical fiber be polarized?

*May or may not be.*

- ❑ What are some advantages of optical fiber over twisted pairs?

*No electrical interference.*

- ❑ As mentioned, there are 15 lights of different wavelengths. Is this frequency division multiplexing?

*Yes, if you transmit all of them simultaneously. But we don't.*

- ❑ Can optical fiber wires be more fragile than copper?

*After packaging, you can't distinguish between the two.*

- ❑ Could you go into more detail on multiplexing?

*Yes, later in this course.*

- ❑ How is the information passed through light?

*Light is modulated to distinguish 1 and 0.*

# Optical Fiber

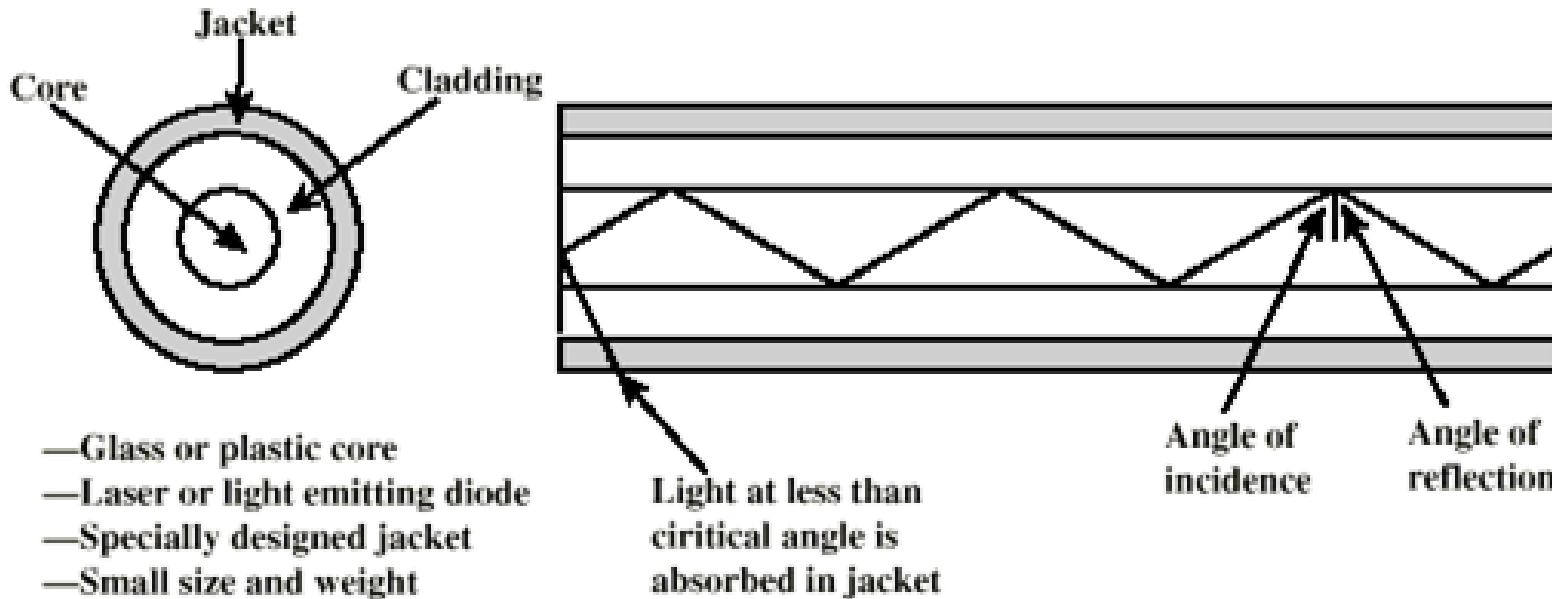

- ❑ A cylindrical mirror is formed by the cladding.
- ❑ The light wave propagates by continuous reflection in the fiber
- ❑ Not affected by external interference  $\Rightarrow$  low bit error rate
- ❑ Fiber is used in all long-haul or high-speed communication
- ❑ Infrared light is used in communication

## Student Questions

- ❑ What are the key characteristics of optical fiber?

*Diameter of the core, index of refraction.*

- ❑ How does the cladding design contribute to minimizing error rates in communication?

*Cladding affects how much of the light is reflected or absorbed.*

*Absorption affects the distance.*

*Errors are caused by multiple waves interfering with each other which is related to the diameter.*

- ❑ Could optical fiber technology eventually make twisted pair or coaxial cables obsolete?

*Yes. But that's far away.*

# Optical Communication...History

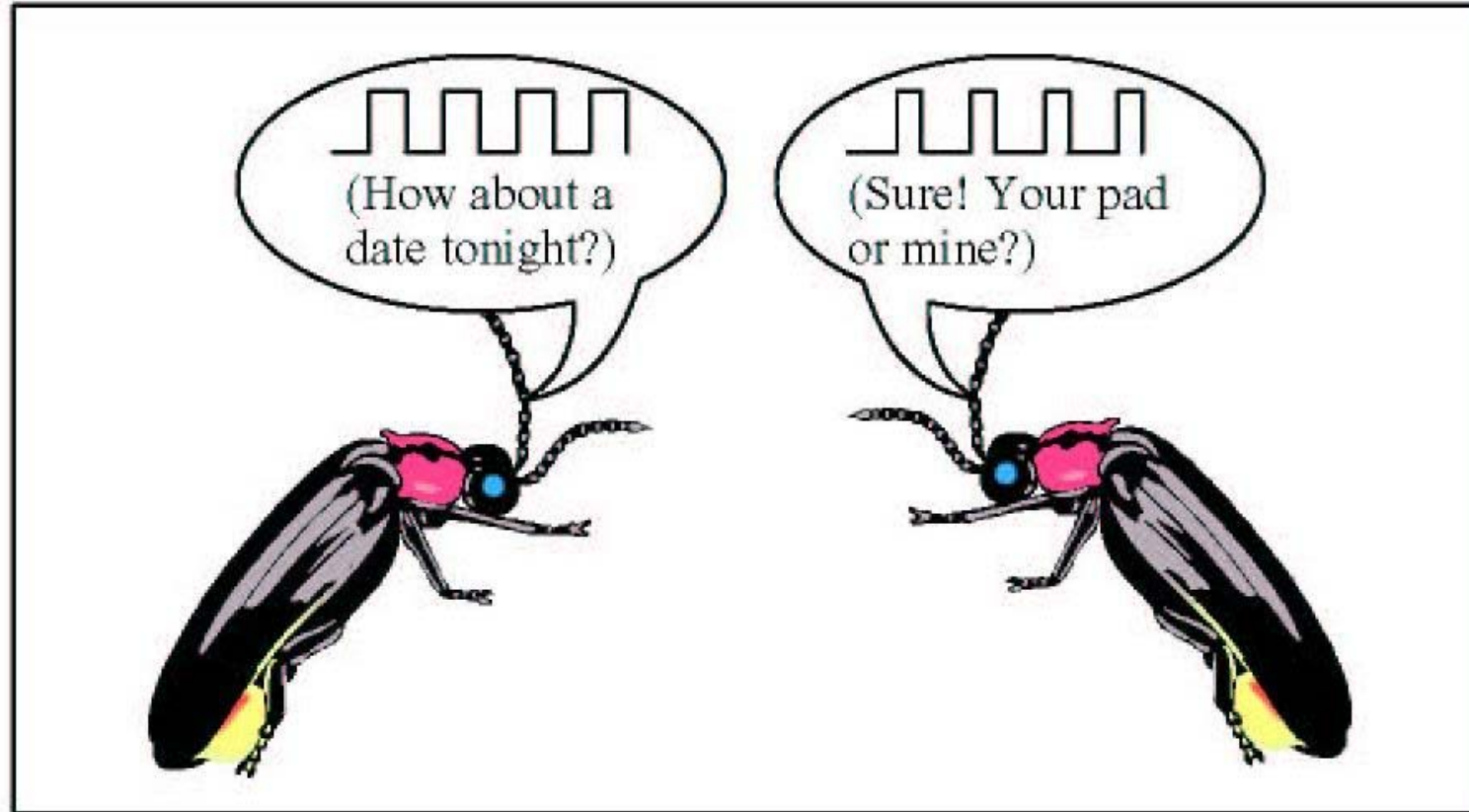

Fireflies use pulse-width modulation.

## Student Questions

- ❑ Do we get the idea of optical communication from fireflies? *No.*
- ❑ Is this what happens in the optical fiber? *Yes.*
- ❑ Why do we transmit a signal? What other ways can we do the same thing today?

*Signal=Communication*

*Oral, electrical, visual, ...*

- 
- ❑ Why have they still not fully figured out Pulse Width Modulation? What challenges does this have?

*It is used but more difficult than simply sensing frequencies.*

# Electromagnetic Spectrum

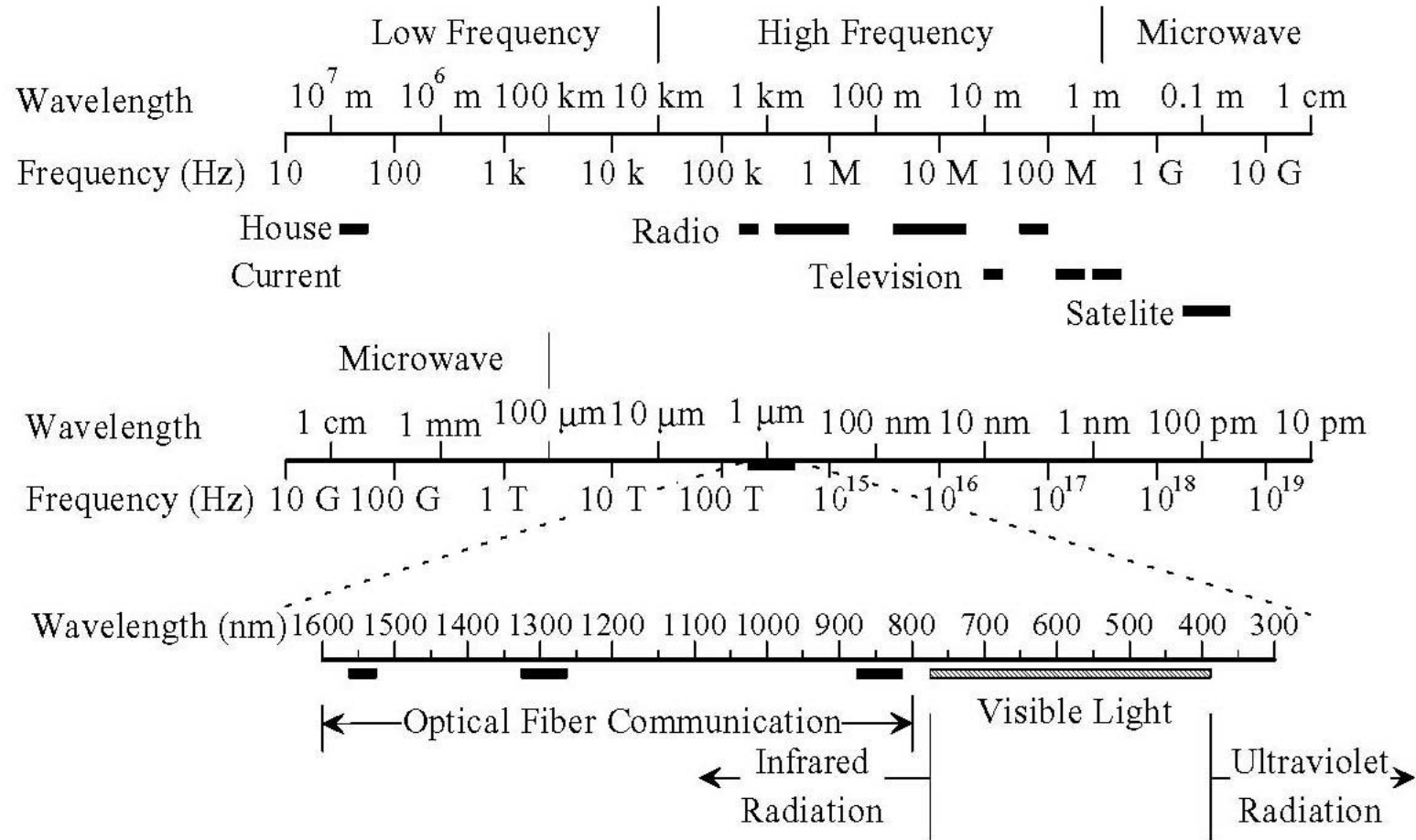

Infrared light is used for optical communication.

## Student Questions

- Why can't we use higher or lower frequencies for optical fiber communication?
- Lower frequencies are all used up.*
- Why do we use infrared light for optical communication and not something else (e.g., ultraviolet)?
- Part of the advanced networking course.*
- How do we interpret the wavelength or frequency as data we can actually understand?
- Coding. Like Morse code.*
- Would there be an advantage to using wavelengths of light with higher frequencies in an optical connection?
- Both advantages and disadvantages.*
- So technically, I can receive a TV signal by radio which can receive a higher frequency, right?
- Yes. TV is a radio too.*
- Does this mean that we can potentially communicate with the wave the same as a microwave oven?
- We do it every day. Wi-Fi is a microwave.*

# Electromagnetic Spectrum

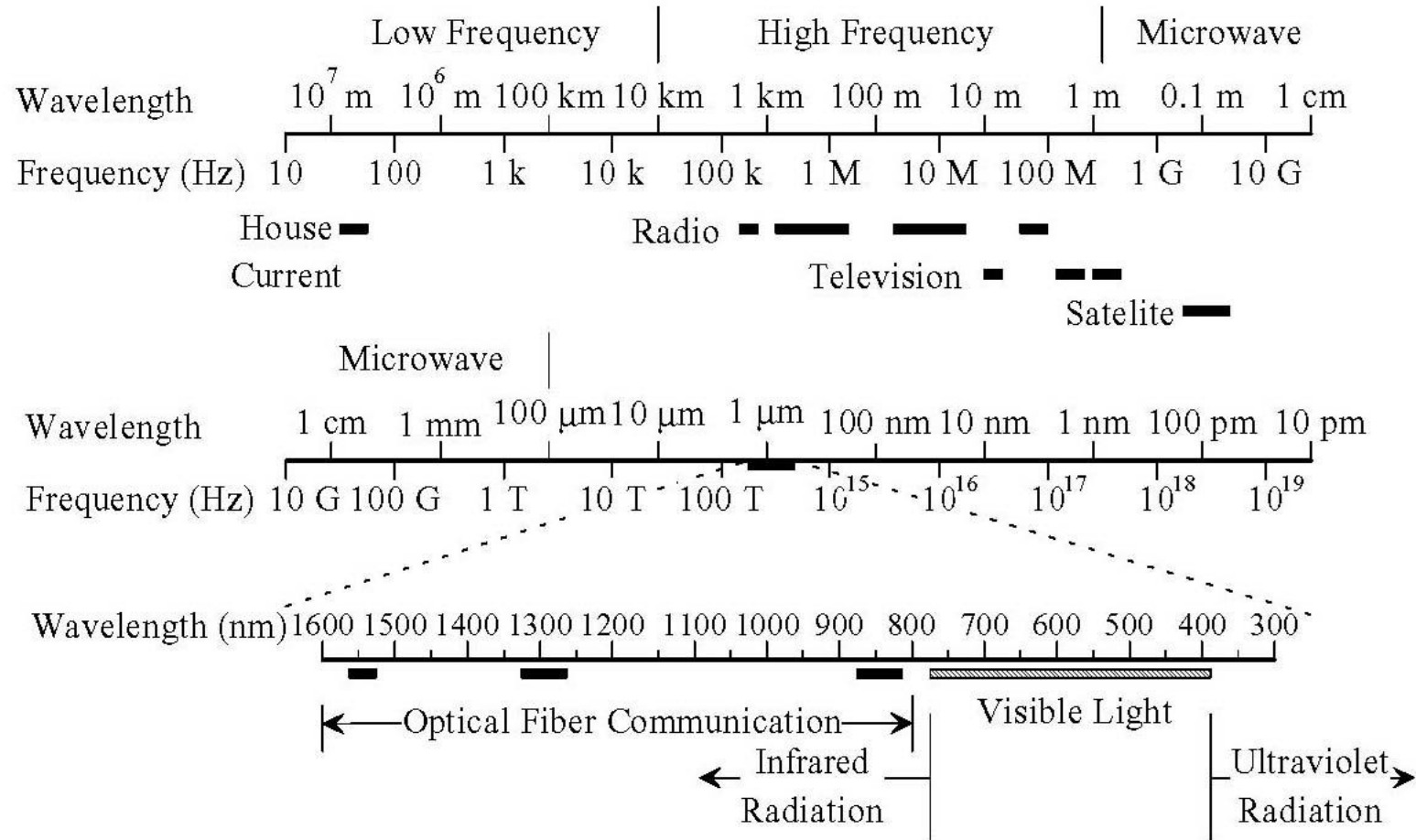

Infrared light is used for optical communication.

## Student Questions

What should we be able to identify on the electromagnetic spectrum?

*Basic relationships between various components. Not the fine print of the numbers.*

What is the value of the Electromagnetic Spectrum figure? Is it just to show the wavelengths of Optical Fiber Communication?

*To understand that sound, electricity, radio, microwave, and light, x-rays are similar.*

What are the black bars in the figure?

*Each black bar has an associated application.*

Do 4G and 5G Wi-Fi mean their frequency?

*No. G=Generation*

Does the 5G network use higher frequency waves than 4G?

*No.*

Are/will the EM waves get to be unsafe for our bodies? How are engineers facing the issue?

*Debatable issue.*

What exactly is bandwidth?

*Width of the frequency band*



# Electromagnetic Spectrum

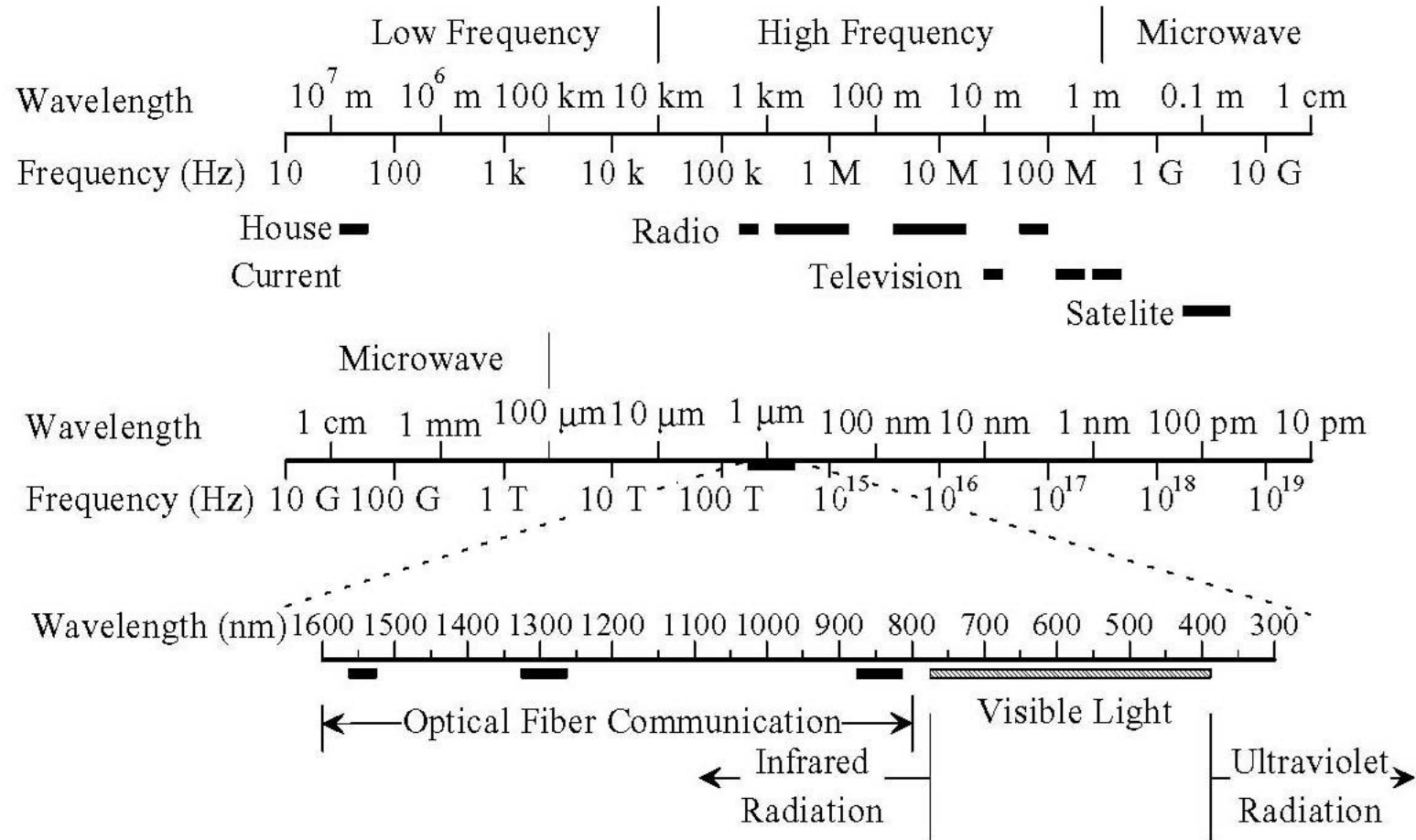

- Infrared light is used for optical communication.

## Student Questions

- Does optical communication use a much higher frequency than copper or wireless communication? How will this affect the transmission speed?

*All electromagnetic signals travel at the same speed.*

- Why is infrared used for optical and not something with a smaller or larger frequency?

*Lower frequencies are cheaper.*

- How about airdrop? Where should it be on this scale?

*It is Bluetooth (Microwave).*

- What is not included in the electromagnetic spectrum?

*Sound*

# Homework 1A: Networking Media

- ❑ [6 points] Which networking media will you use for the following applications and why?
- Very large file transfer at home
- High-speed multiple-channel video transmission at an office
- News reading while traveling in a car

Note: Do not write the name of the protocol.  
Write the name of the media and justify it.

## Student Questions

- ❑ Do we need to do this homework, or is this just for some previous semester?

*While the video is from a previous live class. The slides have been updated for this semester. So, yes, you need to do the homework and submit it on the Monday following the class discussion.*

- ❑ Are homework 1A and 1B both due next Monday? (Jan. 24th) *Yes.*
- ❑ By plain text files, do you mean txt files? *Yes.*
- ❑ So we need a paragraph for each question? *Yes.*
- ❑ What do you mean by Networking media? *UTP, STP, coax, wireless, fiber, ...*

- ❑ I don't see an assignment for submitting this on Canvas. Also, when must we submit this by?

*Next Monday.*

- ❑ Will we need to turn in HW 1A into Canvas?

*Yes.*

- ❑ Where do we submit our Homework answers?

*Canvas*



# Homework 1A: Networking Media

- ❑ [6 points] Which networking media will you use for the following applications and why?
- Very large file transfer at home
- High-speed multiple-channel video transmission at an office
- News reading while traveling in a car

Note: Do not write the name of the protocol.  
Write the name of the media and justify it.

## Student Questions

- ❑ Will this Homework 1A be our homework this semester?

*This is the homework this week.*

*Due on Monday.*

- ❑ Is the HW 6 points per question?

*Total 6 points.*

- ❑ Should we expect weekly homework to be due the following week?

*The homework is always due on the Monday after the class covers the slide.*

# Network Edge: Enterprise Networks

- ❑ Ethernet
- ❑ Wi-Fi

## Student Questions

- ❑ What is a Network Edge?  
*Opposite of Network core.*
- ❑ What are the differences between Ethernet and twisted pair, Wi-Fi and microwaves?

*Will be covered shortly*

---

# Ethernet



- ❑ Uses UTP (Unshielded Twisted Pair)
- ❑ 10 Mbps, 100 Mbps, 1 Gbps, 10 Gbps
- ❑ Originally bus, now point-to-point (Star) topology

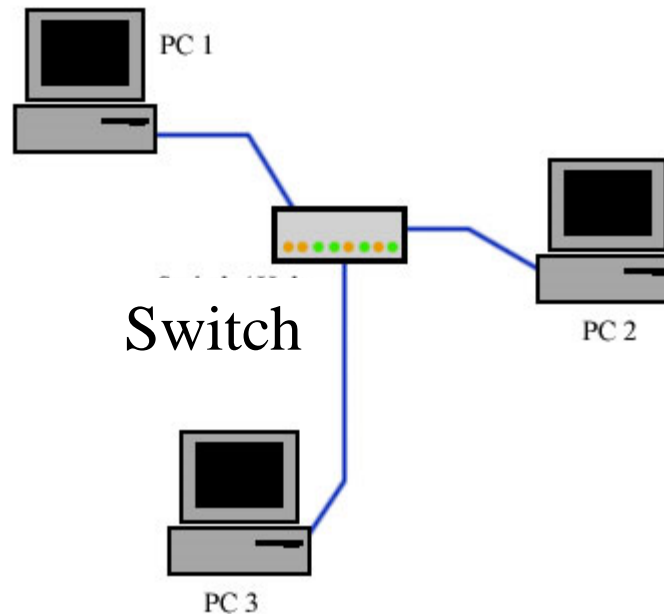
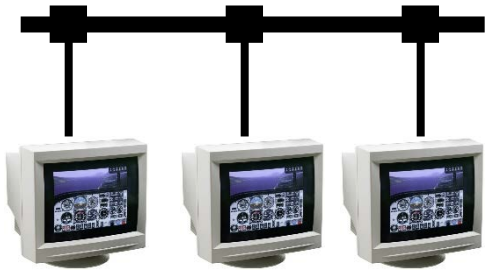

## Student Questions

- ❑ Was it the bus or star topology that was more robust against single connection faults?

*The bus is susceptible to single cable faults.*

- ❑ Was it difficult to transit from the bus to the star topology?

*No. Both existed at the same time.*

- ❑ If one client fails in a bus, is the whole chain broken? *Maybe. Maybe not.*
- ❑ Do internet protocols specify which media they will use for communication?

*No, except for media access protocols.*

- ❑ Do we need to remember the transmission rate of different network mediums (ex., Ethernet, UDP...)

*Not yet.*

- 
- ❑ Why is the star topology for Ethernet more resilient to a lousy connection than a Bus?

*A single faulty node cannot shut down the entire network.*

---

# Ethernet



- ❑ Uses UTP (Unshielded Twisted Pair)
- ❑ 10 Mbps, 100 Mbps, 1 Gbps, 10 Gbps
- ❑ Originally bus, now point-to-point (Star) topology

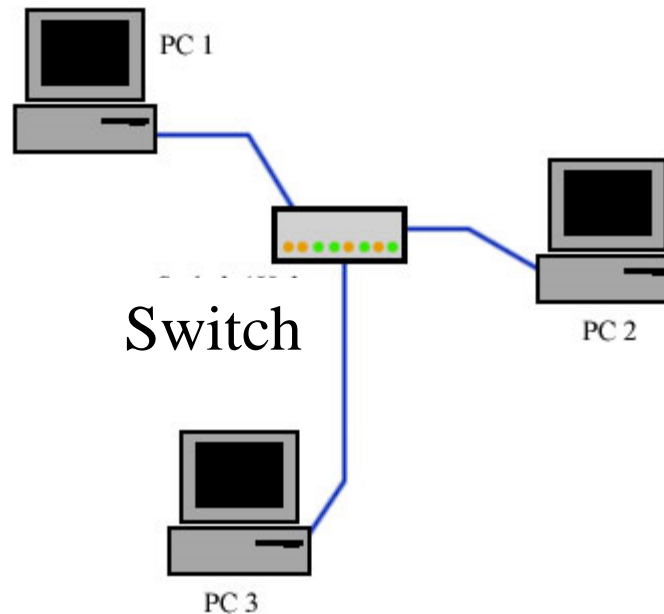
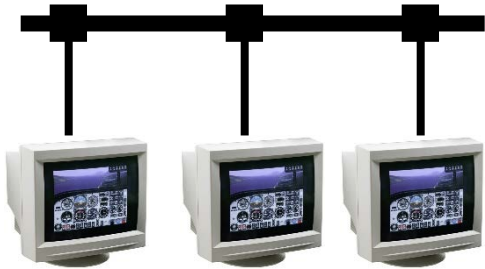

## Student Questions

- ❑ What are the different data transmission speeds supported by Ethernet as mentioned in the slide, and how has the topology of Ethernet networks evolved from its original design?

*To be discussed in Chapter 6.*

- ❑ Do you think that Ethernet will eventually be able to achieve speeds greater than 10Gbps or has it reach the limit of the medium?

*100Gbps and 400Gbps are under design.*

- ❑ Will Ethernet still be used in the near future?

*As far as we can see.*

# Wi-Fi

- ❑ IEEE 802.11  
(Institution of Electrical and Electronic Engineers)
- ❑ Uses 2.4 GHz and 5.8 GHz



## Student Questions

- ❑ Wi-Fi usually has a router and modem, is a modem a host and a router an intermediate system?

*Modem, too, is an intermediate system.*

- ❑ Can we not follow the IEEE guidelines?

*We do.*

- ❑ Can you elaborate on how 2.4 GHz "ran out" and why we need to expand to 5.8 GHz?

*Too many nodes broadcasting on the same frequency overloaded 2.4 GHz.*

- ❑ Are 2.4 and 5.8 also called 2G and 5G? If the frequency is fixed, why in real life is the speed still changing or fluctuating?

*No. 2G and 5G are different generations.*

*Covered in Wireless chapter.*

- ❑ Do we use 2.4 GHz and 5.8 GHz at the same time? E.g., when we close the router, we use 5.8 GHz, further away we use 2.4 GHz.

*We started with lower/cheaper frequencies.*

# Access Networks

- ❑ DSL (Digital Subscriber Line)
- ❑ Cable
- ❑ Fiber-To-The-Home
- ❑ Wi-Fi
- ❑ LTE (Long Term Evolution)

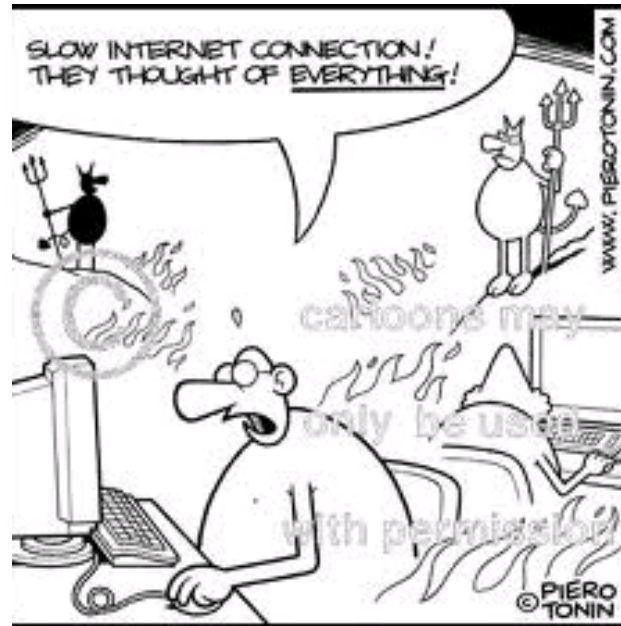

## Student Questions

- ❑ How is LTE different from 4G?  
*This is discussed in Module 7. LTE is 3.9G or pre-4G.*
- ❑ What is LTE/ what does Long Term Evolution mean? *Please wait till Module 7.*
- ❑ Does Fiber to the Home mean Optical fiber? *Yes.*
- ❑ What exactly is Fiber-To-The-Home?  
*AT&T Fiber and Verizon Fiber are FTTH services.*
- ❑ What exactly does "Long Term Evolution" mean? *"In the distant future."*
- ❑ Can you explain how dial-up Internet works? How, if at all, does it relate to DSL?  
*Too detailed for now.*
- ❑ Was fiber to the homeless common only because of cost, or were there other factors as well? *Cost.*
- ❑ Is 4G LTE inferior to 5G? *Yes.*
- ❑ Have any alternative access networks like Google Balloons gained significant traction over FTTH or 5G LTE?  
*Low-Earth Orbit satellites now fill the need.*

# Access Networks

- ❑ DSL (Digital Subscriber Line)
- ❑ Cable
- ❑ Fiber-To-The-Home
- ❑ Wi-Fi
- ❑ LTE (Long Term Evolution)

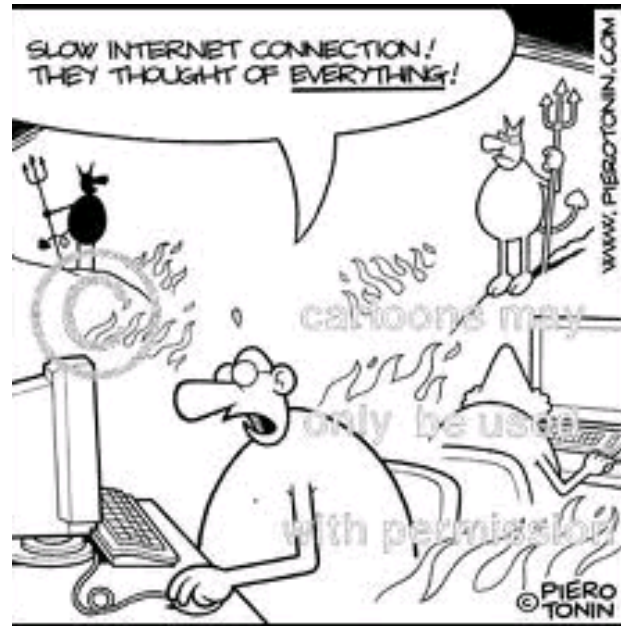

## Student Questions

- ❑ Since the theoretical speed of DSL is much lower than that of fiber-to-the-home, do you think DSL will eventually be fully replaced by other networks such as fiber-to-the-home?

*Yes.*



# Digital Subscriber Line (DSL)

- Can transmit very high data rates on phone wire using special equipment at the phone company, allowing higher frequency signal

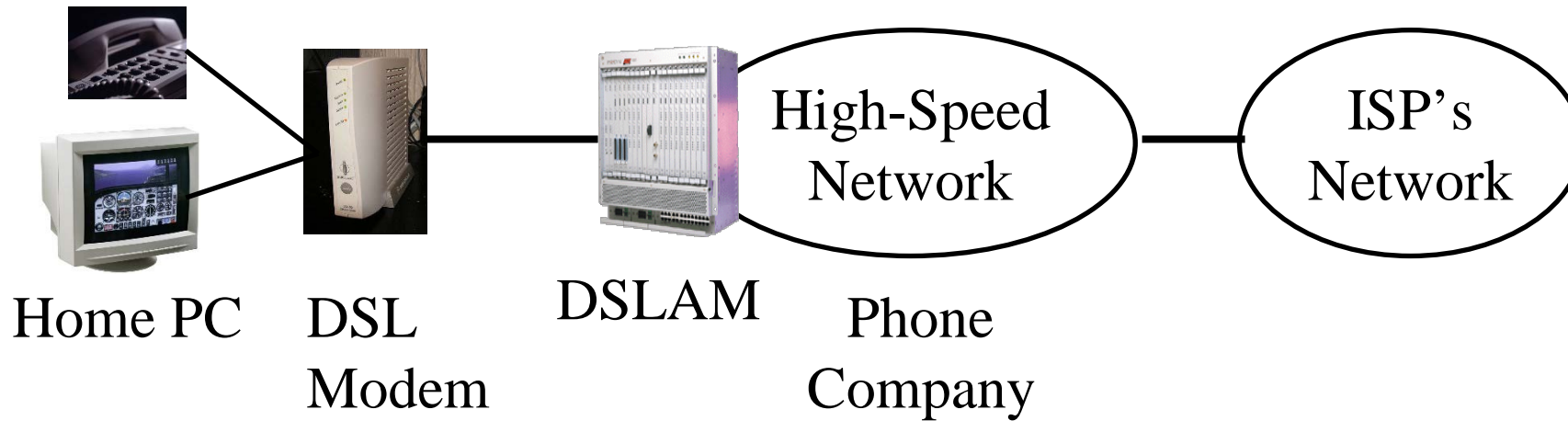

- DSL Access Multiplexer (**DSLAM**)
- 100 kbps - 100 Mbps

## Student Questions

- Where do we turn in our in-class assignment?

*Unless indicated otherwise, all homework should be submitted on Canvas.*

- What kind of wire is a phone wire?  
*The wire is used to connect to your home phone.*
- Is DSL the same thing as Dial-Up?  
*DSL is a data service using the same wires that were used for phones.*

- Is DSL similar to a phone line?
- What is a multiplexer?

*Combines many circuits*

- Is the connection between DSL Modem and DSLAM analog? *No. It is digital.*
- Is this method in use today? *Yes.*
- Are DSL Modems and DSLAM intermediate systems? *Yes.*
- Why is DSL only used for phone companies?

*They own subscriber lines.*

- Are DSL the same as dial-up Internet?

*No. Dial-up requires a modem for digital to analog conversion. DSL takes in digital directly.*

# Digital Subscriber Line (DSL)

- Can transmit very high data rates on phone wire using special equipment at the phone company, allowing higher frequency signal

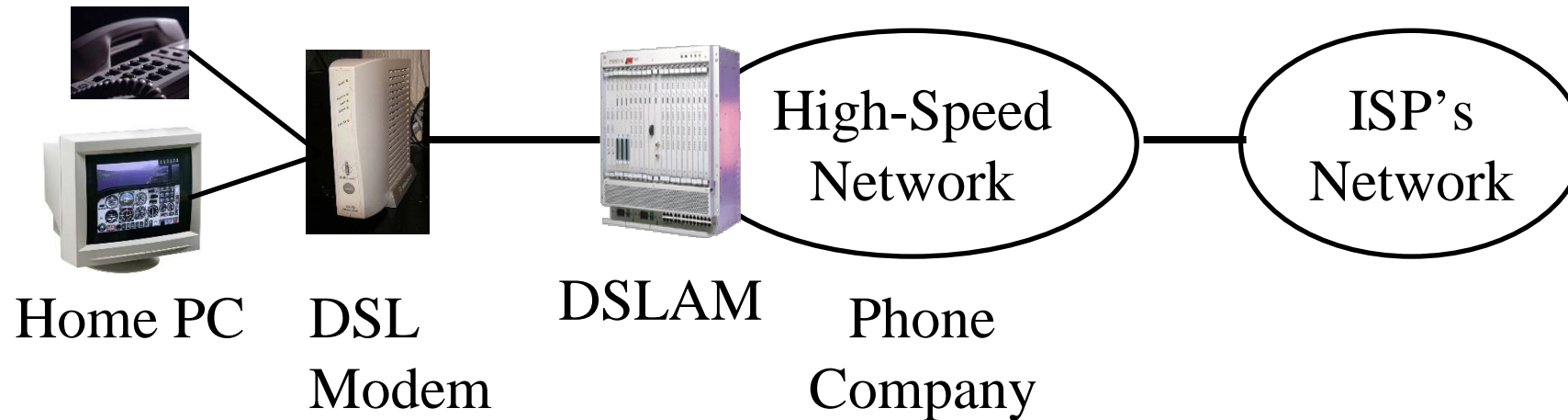

- DSL Access Multiplexer (**DSLAM**)
- 100 kbps - 100 Mbps

## Student Questions

- What's the difference between the microwaves used in Wi-Fi and microwave ovens?

*Power level. kW vs.  $\mu$ W.*

- Why does the signal have information?

*Information to be transmitted is encoded in to the signal.*



# Cable

- ❑ Cable companies have a very-high-speed medium (for video transmission)
- ❑ Phone wire = 4kHz for voice  
Video Cable = 500 MHz for video  
One TV Channel = 6 MHz
- ❑ 100 Mbps down/10 Mbps up
- ❑ Fiber in the main line + Coax in tributaries  
⇒ Hybrid Fiber Coax (HFC)



Cable Modem

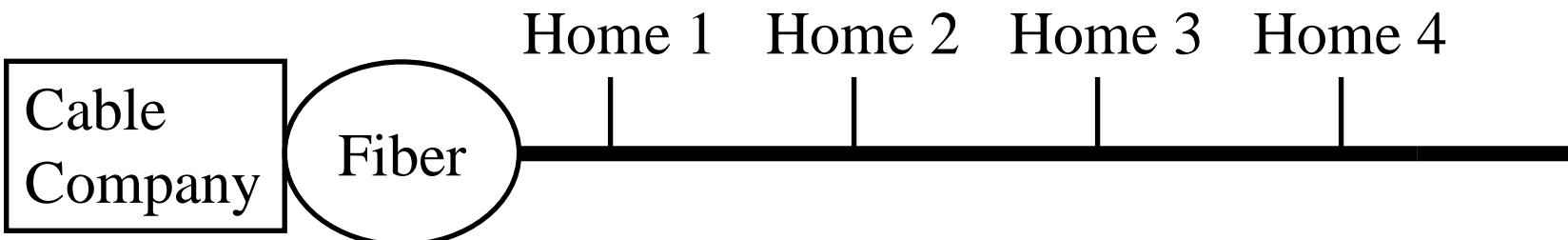

## Student Questions

- ❑ Why is the upload speed always slower than the download speed?
- ❑ Is it the only difference in structure between DSL and cable that DSL uses UTP while cable uses coaxial wire?

*Not always. On point-to-point fiber, upload = download.*

*No, there are many other differences. Not just media but also protocols.*

- ❑ Will using a longer Ethernet cable slow down the connection speed?

*It depends upon the type of Ethernet. Older Ethernet -yes. Current Ethernet -no.*

- ❑ What is the benefit of HFC?
- ❑ What's the relationship between front haul/backhaul and download/upload?

*Fronthaul = Access*

*Backhaul = Core*

*Download = Towards the customer*

*Upload = Towards the provider*



# Cable

- ❑ Cable companies have a very-high-speed medium (for video transmission)
- ❑ Phone wire = 4kHz for voice  
Video Cable = 500 MHz for video  
One TV Channel = 6 MHz
- ❑ 100 Mbps down/10 Mbps up
- ❑ Fiber in the main line + Coax in tributaries  
⇒ Hybrid Fiber Coax (HFC)



Cable  
Modem

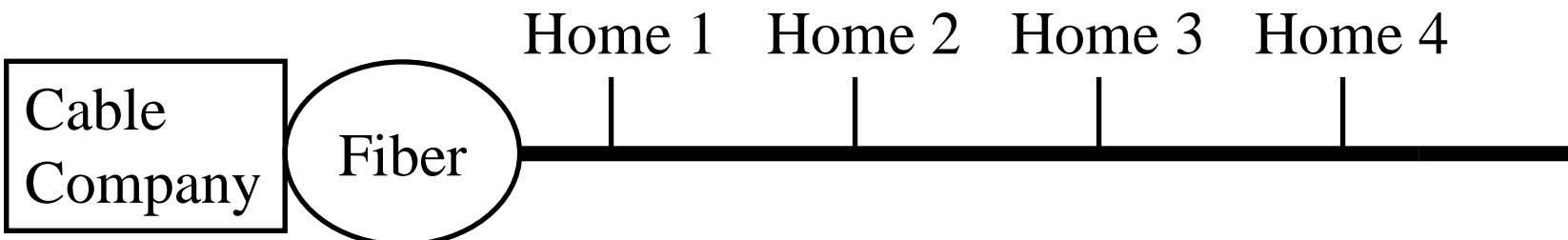

## Student Questions

- ❑ Is Cable Modem the same as DSL Modem? When/how is Cable Modem used?

*Phone companies provide phone and DSL. Cable companies provide TV and Cable Internet.*

- ❑ Why do cable companies use HFC instead of pure fiber for connecting homes?

*Optical devices are expensive compared to electrical devices.*

- ❑ What frequencies are used for voice and video transmission in cable systems?

*50 MHz-1 GHz.*

- ❑ How do HFC systems enhance data transmission capabilities?

*HFC is just a medium designed to minimize loss.*



# Cable

- ❑ Cable companies have a very-high-speed medium (for video transmission)
- ❑ Phone wire = 4kHz for voice  
Video Cable = 500 MHz for video  
One TV Channel = 6 MHz
- ❑ 100 Mbps down/10 Mbps up
- ❑ Fiber in the main line + Coax in tributaries  
⇒ Hybrid Fiber Coax (HFC)



Cable  
Modem

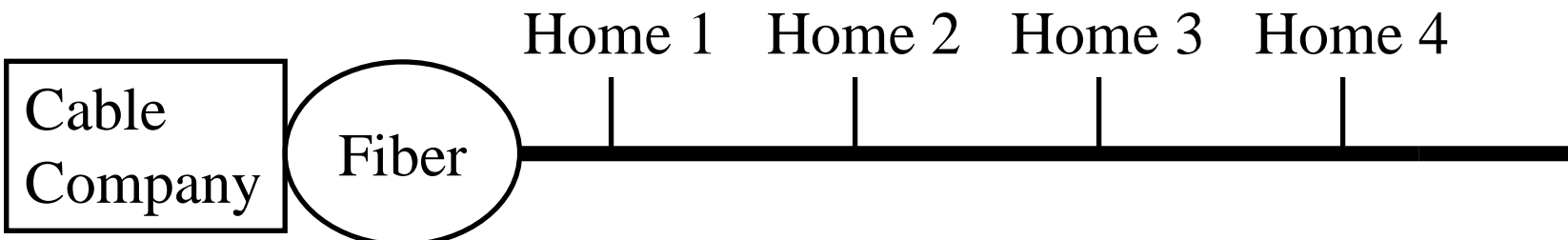

## Student Questions

- ❑ What are the characteristics of coaxial cables? (e.g. faster speed/higher costs/robust etc.)  
*Lower interference and hence higher speed but thick and so not as easy to handle or make multiple pairs.*

# Fiber-To-The-Home (FTTH)

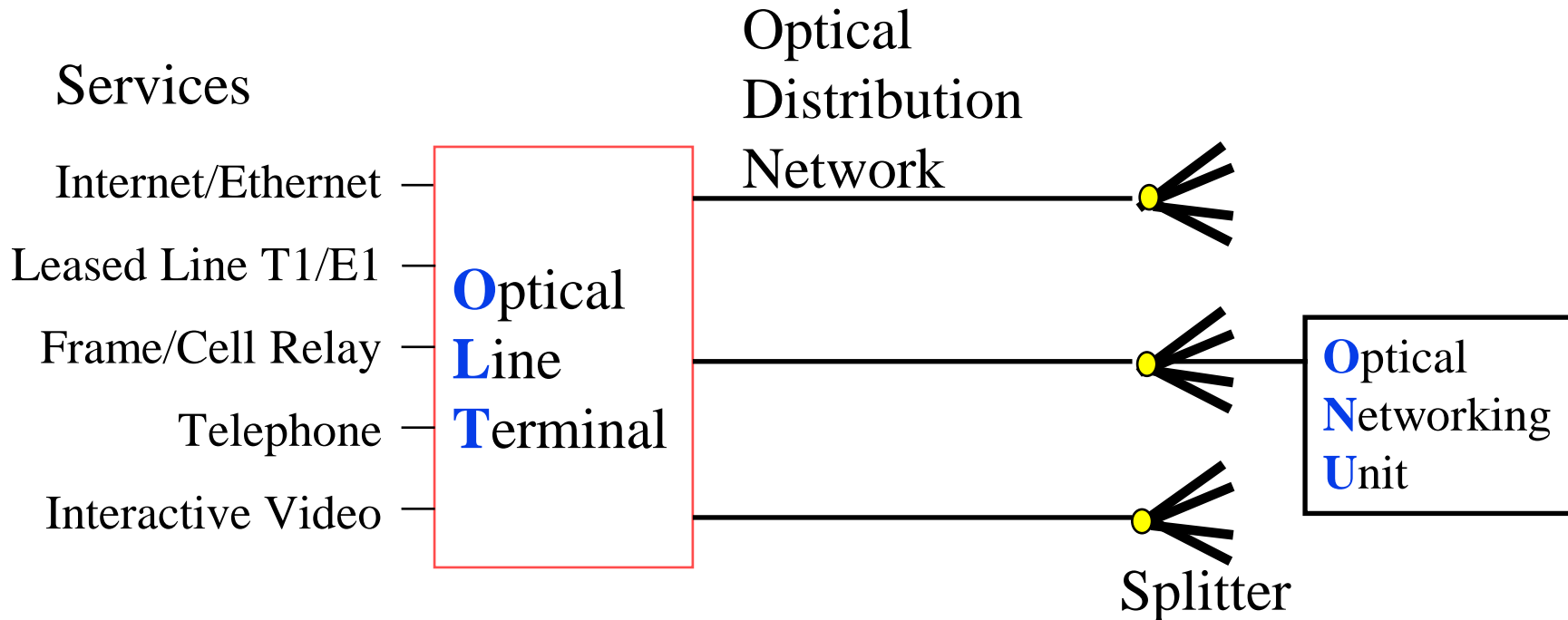

- ❑ 1+ Gbps per home. Multiple services.
- ❑ No electronic components in the distribution system  
⇒ Passive ⇒ Reliable
- ❑ Passive Optical Network (PON)

## Student Questions

- ❑ What is the difference between analog and digitalized DSL?

*Analog signal* 

*Digital signal* 

- ❑ How frequently is FTTH used in the US compared to cable?

*AT&T Fiber just came to St. Louis.*

- ❑ Is FTTH more reliable than cable?

*Not necessarily.*

- ❑ Do DSL and cable also use a passive splitter as FTTH does? If not, then how do they distribute the packets?

*DSL has switches and routers to distribute packets. These are not passive. The cable can use switches or hubs. Hubs can be passive but are not generally used.*

- ❑ Is OLT at home and ONU at the source?

*OLT at phone co. ONU at home.*

- ❑ Are cable and Fiber-to-the-Home installed at the same location in a neighborhood, for instance?

*There may not be any cable unless it is HFC.*

- ❑ What counts as active components? Can you give an example?

*Power makes a component active.*

# Fiber-To-The-Home (FTTH)

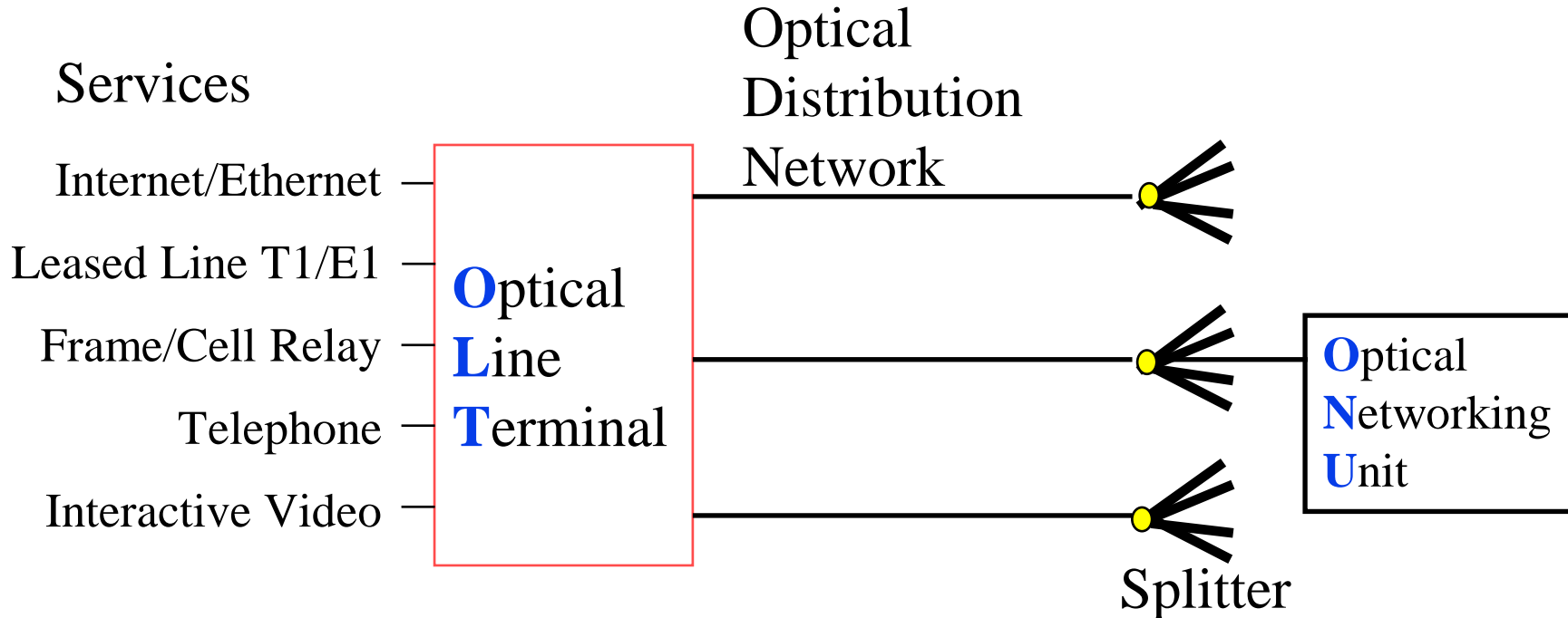

- ❑ 1+ Gbps per home. Multiple services.
- ❑ No electronic components in the distribution system  
⇒ Passive ⇒ Reliable
- ❑ Passive Optical Network (PON)

## Student Questions

- ❑ If we a fiber split into 5 and go to 5 different users. Then before the split, all the data for 5 people are combined together; is that correct?  
*Each home has its own key and can only decrypt only its traffic.*
- ❑ You mentioned that OLT and ONU are active. Does that mean that if a user wants to quit, then the company can prevent him from stealing the network by ONU? Since the company won't uninstall the fibers from their home, right?

*OLT drops all packets from sources that have not paid*

- ❑ Does optical fiber not need repeaters? How far can an optical fiber signal propagate before degrading, or do they not degrade?

*They need repeaters but after a long distance.*

- ❑ Is FTTH more common now?

*Yes. I have FTTH.*

- ❑ How is the optical signal split on fiber?

*Light naturally goes to all downstream paths.*



# Fiber-To-The-Home (FTTH)

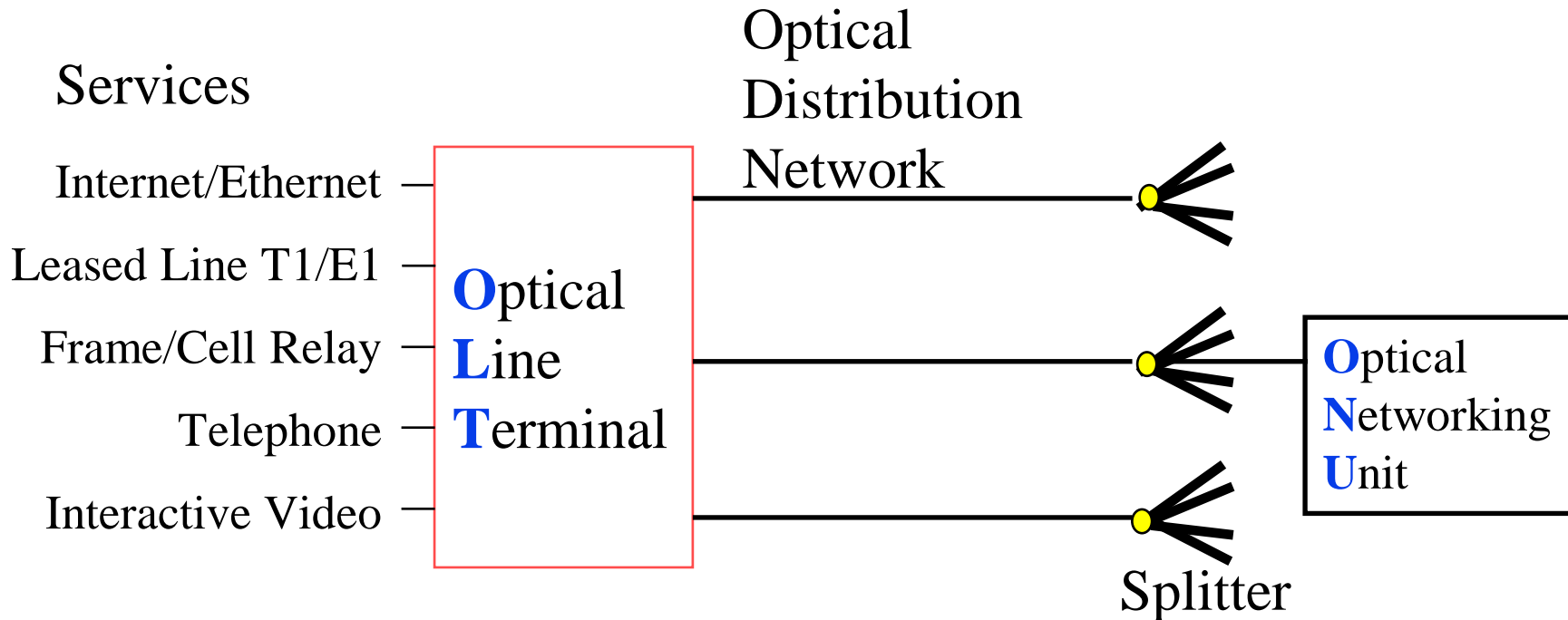

- ❑ 1+ Gbps per home. Multiple services.
- ❑ No electronic components in the distribution system  
⇒ Passive ⇒ Reliable
- ❑ Passive Optical Network (PON)

## Student Questions

- ❑ Since it's a passive split, do we receive all the data and only use our key to decrypt the part corresponding to that key? Can we access other people's data without knowing their keys?

*Everyone knows where their part begins and ends. They can see others' parts but cannot decrypt those.*

- ❑ Is the connection between ONU and OLT similar to the bus? Can a misbehaving ONU disrupt one of the OLTs downstream in its entirety?

*OLTs are upstream. The ONUs use different frequencies and cannot affect other ONUs or OLTs.*

- ❑ How does the design of the Optical Distribution Network contribute to the reliability of multiple services delivered through Fiber-To-The-Home (FTTH)?

*Passive is more reliable*

# Fiber-To-The-Home (FTTH)

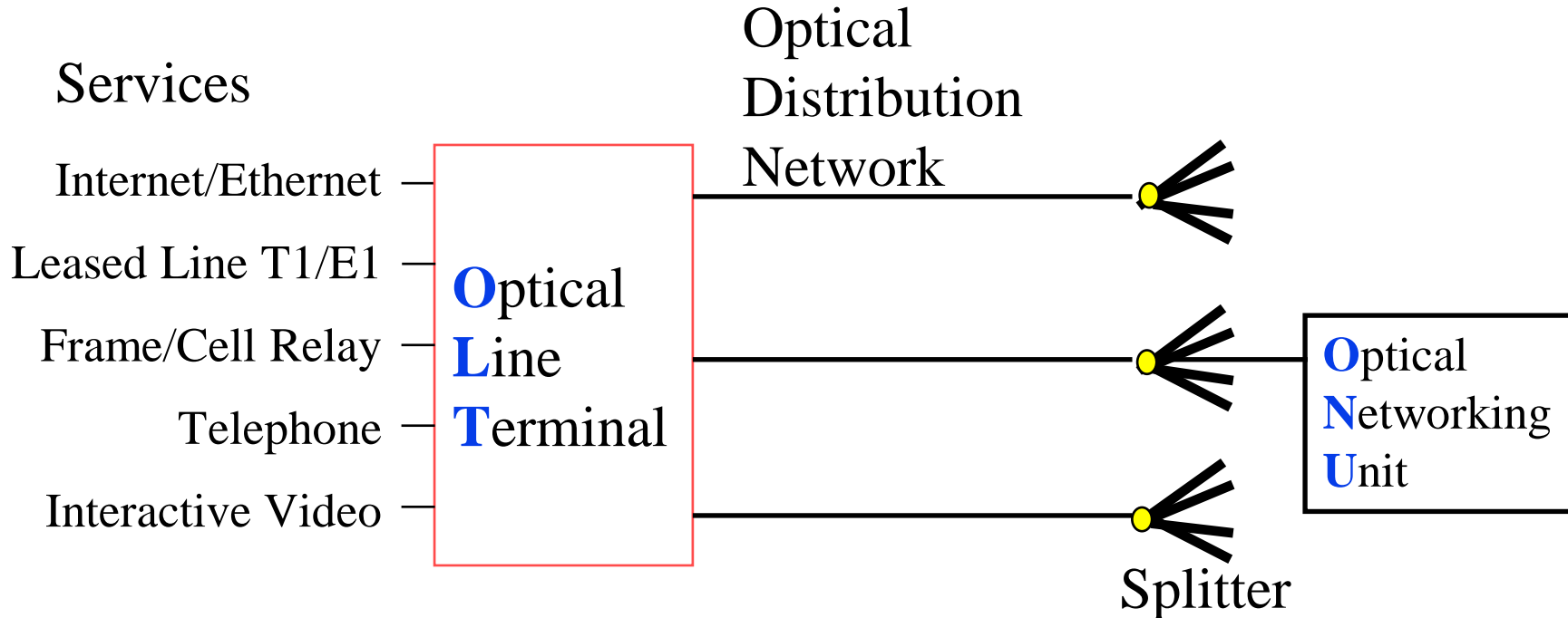

- ❑ 1+ Gbps per home. Multiple services.
- ❑ No electronic components in the distribution system  
⇒ Passive ⇒ Reliable
- ❑ Passive Optical Network (PON)

## Student Questions

- ❑ In this picture is the PON the lines between the OLT and the Splitters?

*PON = OLT + Fiber + Splitter + ONU*

- ❑ Will each of the ONUs get the same amount of bandwidth?

*Generally yes. But electrical circuits at the end can control the amount delivered.*

- ❑ Is electronic components the same as active components?

*Active=Powered, Passive=No power*

- ❑ Fiber optics can achieve such high speeds because it has very low delay?

*No. Very low interference.*

# Wireless Access Networks

- ❑ Wi-Fi hot spots
- ❑ Cellular access: 2G/3G/4G (LTE)

## Student Questions

- ❑ Can you explain what LTE is as well as 2G and 3G? Where on the EM Spectrum does LTE fall?

*1G/2G/3G/4G/5G are all wireless telecom technologies. We will cover them briefly in Chapter 7. LTE is 3.9G or pre-4G. All of these currently use 700 MHz-5GHz spectra. The spectrum has to be purchased in Government Auctions.*

- ❑ Can you explain the difference between LTE and 4G? Why LTE cannot be a single generation?

*LTE tried but did not meet the 4G requirements. Discussed in detail in CSE574S.*

---

# Network Performance Measures

- ❑ Delay
- ❑ Throughput
- ❑ Loss Rate

## Student Questions

- ❑ Which of the Network Performance Measures are most used/valuable?

*Throughput*

- ❑ What's the difference between throughput and bandwidth?

*Throughput = bits/sec*

*Bandwidth = Hz*

*They are often used interchangeably by many on the web.*

- ❑ Can we use bandwidth to evaluate the network performance?

*Throughput is more appropriate.*

- ❑ Is UTP more effective than STP? Or is it just used because it's cheaper?

*It is easier to handle and it is cheaper.*

# Throughput

- ❑ Measured in Bits/Sec
- ❑ Capacity: Nominal Throughput
- ❑ Throughput: Realistic
- ❑ Bottleneck determines the end-to-end throughput



- ❑ Net end-to-end capacity = 10 Mbps
- ❑ Actual throughput will be less due to sharing and overhead.

## Student Questions

- ❑ Can you define overhead?  
*Overhead = Throughput lost due to Packet headers and delays caused by routing. We will discuss these in the next few slides.*
- ❑ Is throughput a unidirectional measurement, or does it take into account two opposite and simultaneous data streams?  
*Throughput on each side is measured and may be different.*
- ❑ What causes overhead?  
*Packet headers and routing messages are examples of overhead.*
- ❑ What sorts of bottlenecks exist limiting E2E throughput?  
*Slow links, slow routers, slow end systems.*
- ❑ Can the total throughput (read and write) exceed the bandwidth of a network?  
*Throughput cannot exceed capacity.*
- ❑ What's the difference between throughput, capacity, and bandwidth?  
*Bandwidth relates to frequency. Capacity is the nominal throughput.*
- ❑ Is the throughput of a network equivalent to the speed of that network?  
*Speed=Capacity. Throughput=Actual output.*

# Throughput

- ❑ Measured in Bits/Sec
- ❑ Capacity: Nominal Throughput
- ❑ Throughput: Realistic
- ❑ Bottleneck determines the end-to-end throughput



- ❑ Net end-to-end capacity = 10 Mbps
- ❑ Actual throughput will be less due to sharing and overhead.

## Student Questions

- ❑ In a multi-hop connection such as the one shown in the figure, would packets travel at 10 Mbps over the whole link, or will the throughput change between each node?

*Throughput cannot exceed the capacity of intermediate links and nodes.*

- ❑ Do bottlenecks include the speed at which the computers/devices on the ends can transmit/receive packets too? *Yes.*
- ❑ Is the so-called bandwidth the same meaning as the throughput here?

*Often it is done but try to use the correct term.*

- ❑ Is the Net end-to-end capacity (Nominal throughput) determined by bandwidth

*Nominal = Design target*

- ❑ What is nominal throughput? What is the bottleneck? Can you elaborate on how sharing could affect throughput?

*Nominal = Design*

*Bottleneck = Slowest component*

- ❑ Does the highest TPS depend on the lowest capacity of transmitters, receivers, and wires? *Yes.*

# Throughput

- ❑ Measured in Bits/Sec
- ❑ Capacity: Nominal Throughput
- ❑ Throughput: Realistic
- ❑ Bottleneck determines the end-to-end throughput



- ❑ Net end-to-end capacity = 10 Mbps
- ❑ Actual throughput will be less due to sharing and overhead.

## Student Questions

- ❑ How does the bottleneck in a network path influence the end-to-end throughput, and why is the actual throughput typically lower than the nominal capacity?

*Throughput = 1/Bottleneck rate*

*Nominal=Actual+overhead*

- ❑ What do you mean by realistic?

*What you get in real use.*

- ❑ What is an example of throughput being different on both sides if there is a bottleneck?

*Bottleneck limits the rate at which packets can get through.*



# Loss Rate

- ❑ Queuing  $\Rightarrow$  Buffer overflow
- ❑ Bit Error Rate on the link
- ❑ Lost packets are retransmitted by the previous node or the source.

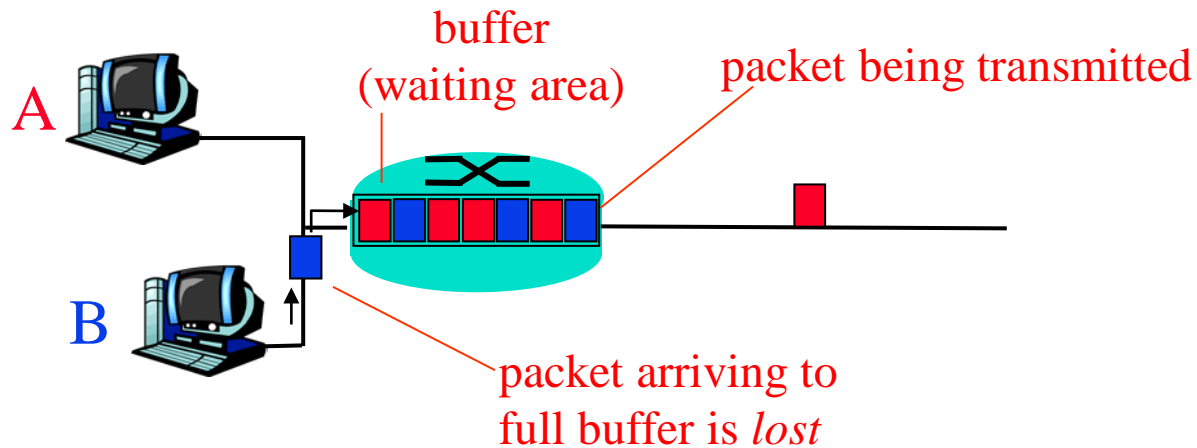

## Student Questions

- ❑ Is there any potential way to reduce the loss rate in wireless transmission?  
*Use coding with lower bits/Hz.*
- ❑ What is packet loss? What causes packet loss? *Errors.*
- ❑ Would you categorize loss rate as a characteristic of network performance, protocol, or both?  
*Both. The network includes protocols.*
- ❑ If the buffer overflows, we lose packets, and if a bit error occurs, that packet gets dropped. *Yes.*
- ❑ How can you reduce the Loss rate?  
*By designing to reduce errors and overflow.*
- ❑ How would the source node know that some bits are lost?  
*Every packet has a number and a length*
- ❑ Can interference or hardware malfunctions cause packet loss, or are these problems a separate issue?  
*Yes. They have a similar effect.*
- ❑ *If a node has multiple output lines, can it transfer multiple packets? Yes*

# Loss Rate

- ❑ Queuing  $\Rightarrow$  Buffer overflow
- ❑ Bit Error Rate on the link
- ❑ Lost packets are retransmitted by the previous node or the source.

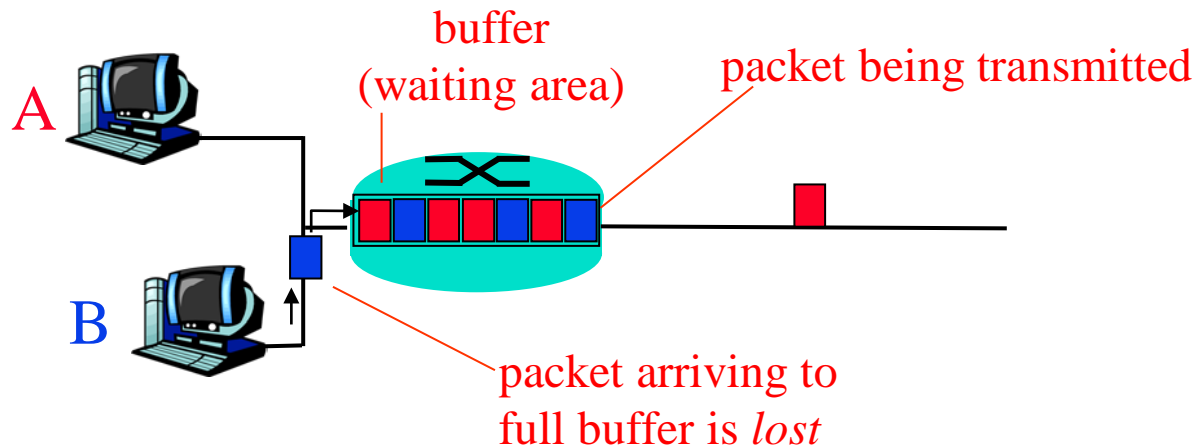

## Student Questions

- ❑ Under what circumstances does buffer overflow lead to packet loss, and what strategies could be implemented to minimize this?

*Congestion control. Discussed in Chapter 4.*

- ❑ What role do queuing and bit error rates play in the overall loss rate of packets, and how can we improve network performance?
- ❑ Queuing may lead to buffer overflow and loss. Errors can make packet un-interpretable.

*Congestion control and error control discussed in Chapter 4.*

- ❑ Higher the throughput, the less likely we are to have packet loss?

*No. Packet loss can happen at any speed.*

# Loss Rate

- ❑ Queuing  $\Rightarrow$  Buffer overflow
- ❑ Bit Error Rate on the link
- ❑ Lost packets are retransmitted by the previous node or the source.

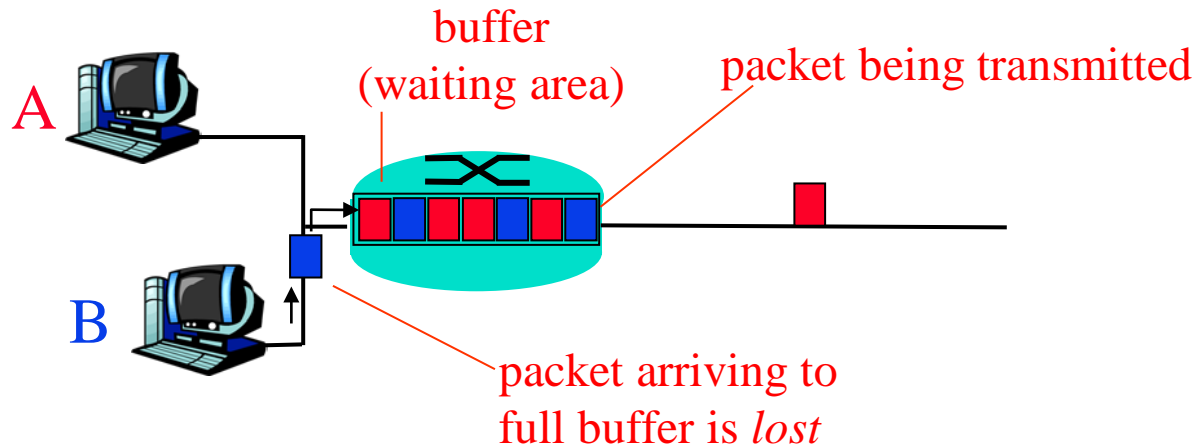

## Student Questions

- ❑ Why does Bit Error Rate cause data loss?

*Damaged packets with bit errors can not be processed correctly.*

# Packet Switching Delay

- ❑ **Processing Delay:** Check packets, decide where to send, etc.
- ❑ **Queuing Delay:** Wait behind other packets
- ❑ **Transmission Delay:** First-bit out to last-bit out on the wire  
= **Packet Length/bit rate**
- ❑ **Propagation Delay:** Time for a bit to travel from in to out  
= Distance/speed of signal
- ❑ **Speed of Signal:** **300 m/μs** light in vacuum, **200 m/μs** light in fiber, **250 m/μs** electricity in copper cables

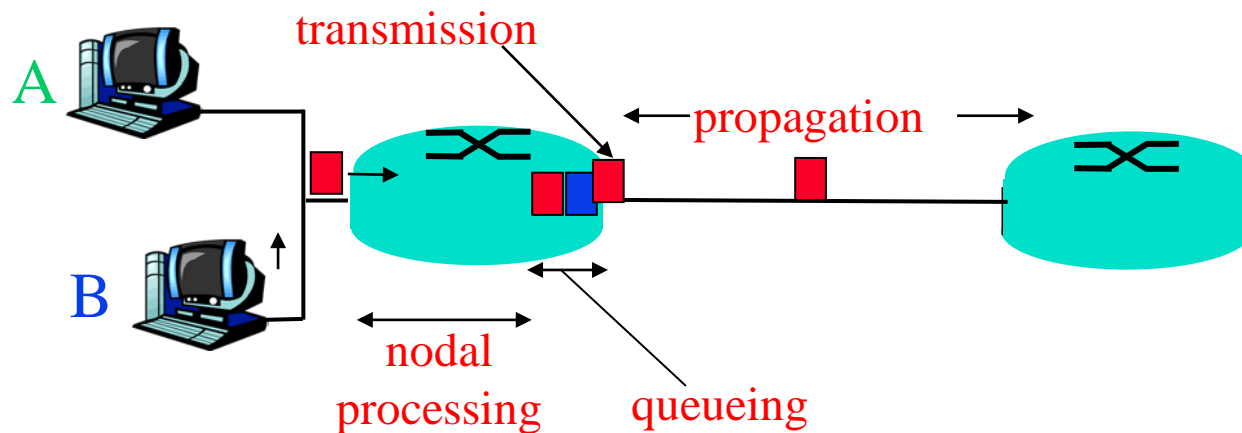

## Student Questions

- ❑ The optical signal travels faster than electricity because light can carry intensive signals on the fiber?  
*Optical signal in fiber travels slower than electricity due to the refractive index of the fiber.*
- ❑ Optical fibers have a larger capacity, and copper cables have less delay. Is that correct?

*Yes.*

- ❑ Does always wired better than wireless in terms of throughput, delay, and loss rate?  
*For the same cost, yes. Some wireless networks are faster than some wired networks, but they are more expensive.*

- ❑ Is propagation delay always happen "after" transmission delay? Do we have to put every bit on the wire first before the first bit is sent to the destination, or can we send it as we go?

*Bits cannot be stopped on the wire. They travel as soon as entering the wire.*

- ❑ Does the delay affect the throughput?  
*Two metrics have a complex relationship. They do not affect each other.*

# Packet Switching Delay

- ❑ **Processing Delay:** Check packets, decide where to send, etc.
- ❑ **Queuing Delay:** Wait behind other packets
- ❑ **Transmission Delay:** First-bit out to last-bit out on the wire  
= **Packet Length/bit rate**
- ❑ **Propagation Delay:** Time for a bit to travel from in to out  
= **Distance/speed of signal**
- ❑ **Speed of Signal:** **300 m/μs** light in vacuum, **200 m/μs** light in fiber, **250 m/μs** electricity in copper cables

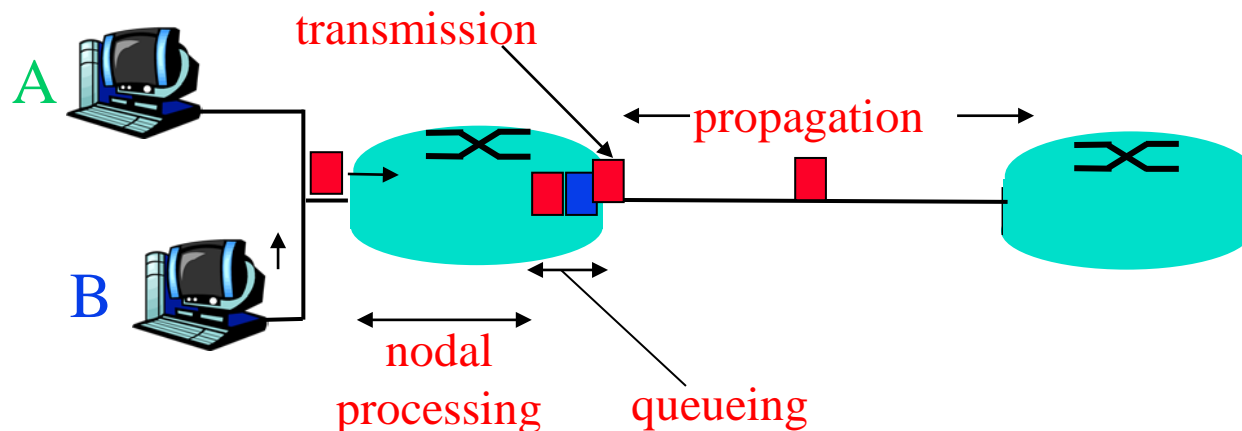

## Student Questions

- ❑ Are all the delays series connections or parallel connections?

*Delays on a series of links add up.*

- ❑ Which kind of delay has the greatest impact on signal transmission?

*It depends on whichever is larger.*

- ❑ What causes packets to get lost in wired mediums? *Bit errors.*

- ❑ What is the difference between Ethernet and IP? *To be covered later.*

- ❑ Are there any other options that are “in-between” a copper and fiber cable? Or some hybrid cable? *I am not aware.*

- ❑ Will we face problems, including queuing delay in the exam?

*Only to the extent it is covered in the book.*

- ❑ How do processing, queuing, transmission, and propagation delays affect overall network efficiency?

*Quality of service is affected by both throughput and delay.*

# Packet Switching Delay

- ❑ **Processing Delay:** Check packets, decide where to send, etc.
- ❑ **Queuing Delay:** Wait behind other packets
- ❑ **Transmission Delay:** First-bit out to last-bit out on the wire  
= **Packet Length/bit rate**
- ❑ **Propagation Delay:** Time for a bit to travel from in to out  
= Distance/speed of signal
- ❑ **Speed of Signal:** **300 m/μs** light in vacuum, **200 m/μs** light in fiber, **250 m/μs** electricity in copper cables

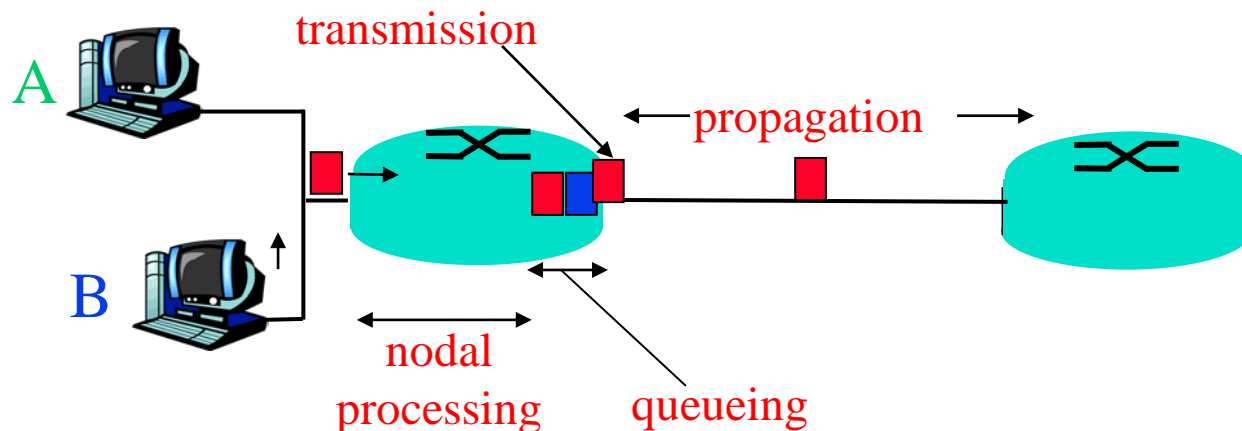

## Student Questions

- ❑ What methods can be used to optimize each type of delay?
- ❑ *Processing requires faster processors or smaller code. Queueing and transmission require faster media. Propagation depends upon the speed of the signal and distance.*
- ❑ Which packet switching delay usually takes the longest amount of time? *Propagation*
- ❑ Will propagation delay affect on transmission delay? *No.*
- ❑ Can you clarify what the queuing delay is?  
*Waiting in the queue because service is slow.*

# Packet Switching Delay

- ❑ **Processing Delay:** Check packets, decide where to send, etc.
- ❑ **Queuing Delay:** Wait behind other packets
- ❑ **Transmission Delay:** First-bit out to last-bit out on the wire  
= **Packet Length/bit rate**
- ❑ **Propagation Delay:** Time for a bit to travel from in to out  
= Distance/speed of signal
- ❑ **Speed of Signal:** **300 m/μs** light in vacuum, **200 m/μs** light in fiber, **250 m/μs** electricity in copper cables

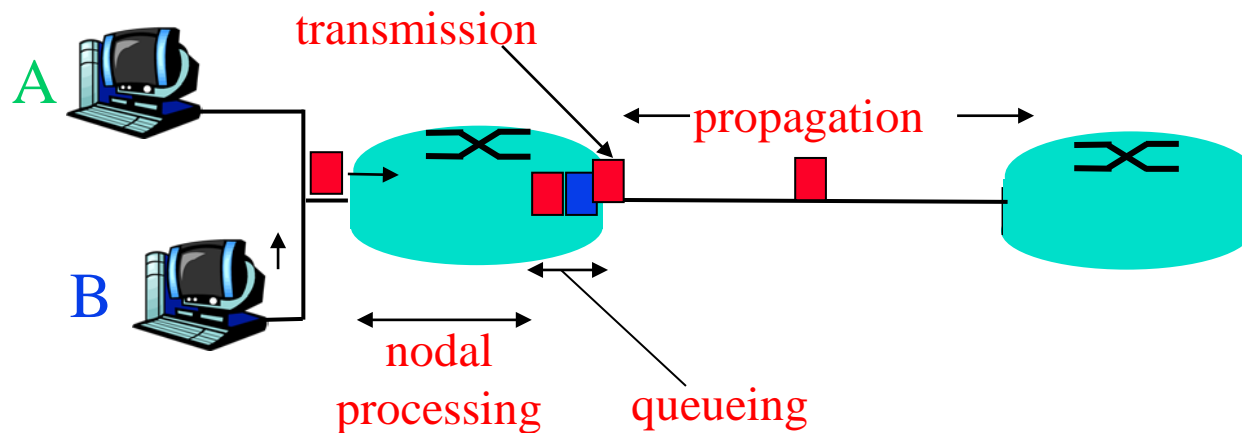

## Student Questions

- ❑ Isn't the bit rate just throughput?  
*Bit rate = Bits/Second.*  
*Some bits are overhead and so actual throughput would be much less.*



# Packet Switching Delay: Example

- ❑ 1500 Byte packets on 10 Mbps Ethernet, 1km segment
- ❑ Transmission Delay =  $1500 \times 8 / 10 \times 10^6 = 1200 \mu\text{s} = 1.2\text{ms}$
- ❑ Propagation delay =  $1000 \text{ m} / 2.5 \times 10^8 = 4 \mu\text{s}$

## Student Questions

- ❑ Will there be any sort of formula sheet accompanying our exams for math questions where they may be relevant?

*One cheat sheet of 8.5x11" paper is allowed in the exam. But you will be better off remembering some of the common constants and formulas.*

- ❑ Does  $2.5 \times 10^8$  come from electricity speed? Are we assuming Ethernet uses a copper cable?

*Yes.*

- ❑ Is this mean that we use the speed of electronic travel through the copper if not declared?

*Yes*

- 
- ❑ Transmission is the time to put the bits onto the wire. Is propagation time to receive the bits?

*No. Propagation=travel from source to destination.*

# Packet Switching Delay: Example

- ❑ 1500 Byte packets on 10 Mbps Ethernet, 1km segment
- ❑ Transmission Delay =  $1500 \times 8 / 10 \times 10^6 = 1200 \mu\text{s} = 1.2\text{ms}$
- ❑ Propagation delay =  $1000 \text{ m} / 2.5 \times 10^8 = 4 \mu\text{s}$

## Student Questions

- ❑ Is there different delay amounts for each layer of the internet or are they all roughly the same?

*Delay at each layer is different because processing in each layer is different.*

# Delay Example (CBR Circuits)

- How long would it take to send a file of 640,000 bits from host A to host B over a circuit-switched network?

All links are 1.536 Mbps

Each link is shared by 24 users

500 ms to establish an end-to-end circuit

Per User Rate =  $1536/24 = 64$  kbps

Time to transfer =  $640\text{kb}/64\text{kb} = 10$  s

Total time =  $.5$  s +  $10$  s =  $10.5$  s

## Student Questions

- Are we assuming the link is using TDM? Wouldn't every user get 1.536 Mbps if it were FDM?

*In FDM, the bit/sec depends on Hertz. Hertz is the unit of frequency. So dividing frequency divides the bit rate among users even in FDM.*

- I don't quite understand why FDM will divide the bit rate as well as TDM. Could you give more explanations about it?

*Two users are sharing 10 MHz for 1 second. Assume one bit/Hz as an example. Each will get 5 Mbps for 1 second using FDM or 10 Mbps for 0.5 s using TDM.*

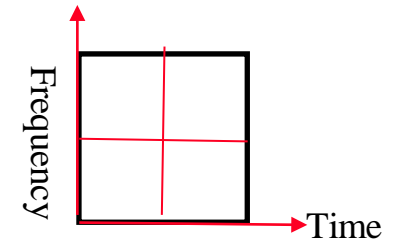

- Can we reuse the unoccupied channel in circuit-switched networks?

*Unoccupied, yes. Unused, No.*

# Delay Example (CBR Circuits)

- How long would it take to send a file of 640,000 bits from host A to host B over a circuit-switched network?

- All links are 1.536 Mbps

- Each link is shared by 24 users

- 500 ms to establish an end-to-end circuit

- Per User Rate =  $1536/24 = 64$  kbps

- Time to transfer =  $640\text{kb}/64\text{kb} = 10$  s

- Total time =  $.5$  s +  $10$  s =  $10.5$  s

## Student Questions

- What are the benefits of copper over optical fibers

Cheaper wire, cheaper interfaces.

- When multiple users share a single circuit, and what are the trade-offs between delay and bandwidth in such scenarios?

*Circuit switching networks generally use time division to share a circuit and generally divide the capacity in a fixed manner.*

# Homework 1B: Network Performance

P5 [14 points]: Consider two hosts, A and B, connected by a single link of rate  $R$  bps. Suppose that the two hosts are separated by  $m$  meters, and suppose the propagation speed along the link is  $s$  meters/sec. Host A is to send a packet of size  $L$  bits to Host B.

- A. Express the propagation delay,  $d_{prop}$  in terms of  $m$  and  $s$
- B. Determine the transmission time of the packet  $d_{trans}$  in terms of  $L$  and  $R$ .
- C. Ignoring processing queuing delays, obtain an expression for the end-to-end delay
- D. Suppose Host A begins to transmit the packet at time  $t=0$ . At time  $t=d_{trans}$ , where is the last bit of the packet?
- E. Suppose  $d_{prop}$  is greater than  $d_{trans}$ . At time  $t=d_{trans}$ , where is the first bit of the packet?
- F. Suppose  $d_{prop}$  is less than  $d_{trans}$ , at time  $t=d_{trans}$ , where is the first bit of the packet
- ⇒ G. Suppose  $s=3 \times 10^8$  m/s,  $L=290$  bits, and  $R=60$  kbps,. Find the distance  $m$  so that  $d_{prop}$  equals  $d_{trans}$ .

## Student Questions

- To clarify, should  $L$  be 280 bits for part G?

*No, it is 290.*

- same question, what would happen if A and B are not connected by a single link, but through several links?

*You will have to compute delays on each link.*

- Are the numbers on the slides the correct ones,  $L = 290$ ?

*See the same question above.*

- When is HW 1B due?

*Next Monday before class.*

# Protocol Layers

- ❑ Problem: Philosophers in different countries speak different languages. The Telex system works only with English.

I believe there is a God!

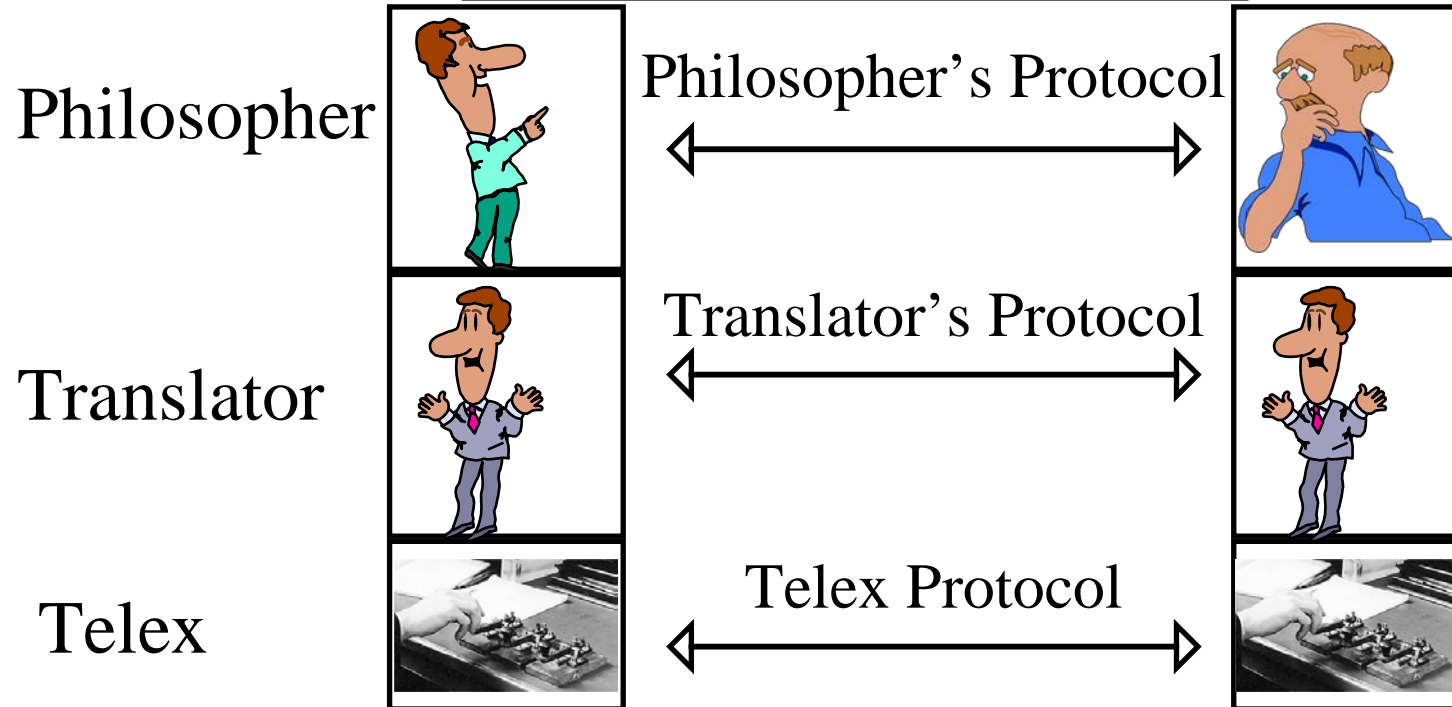

## Student Questions

- ❑ Are there any protocols between philosopher and translator or between translator and telex?

*Yes, those are called APIs. Not protocols.*

# What is a Networking Protocol?

- Network protocols define the format of messages, their meanings, sequence, and actions



## Student Questions



# ISO/OSI Reference Model

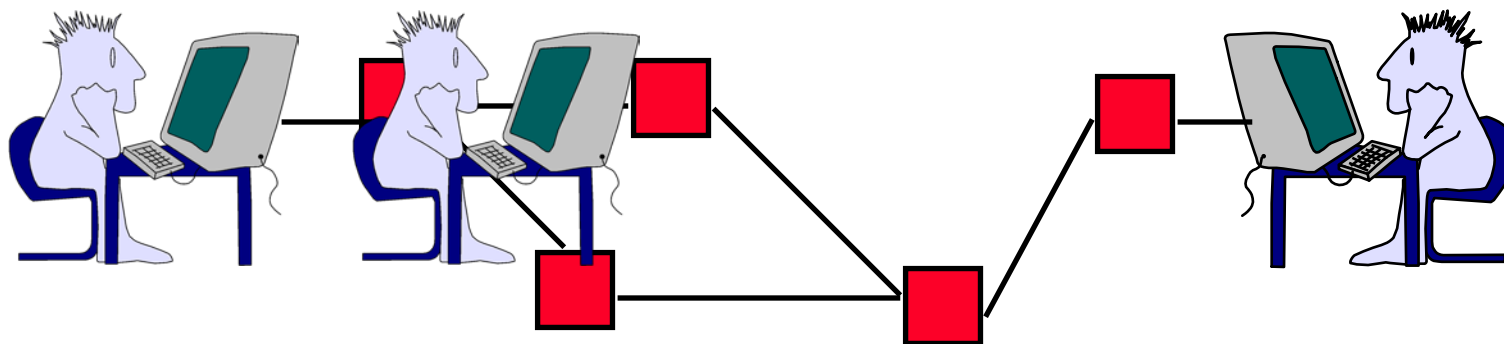
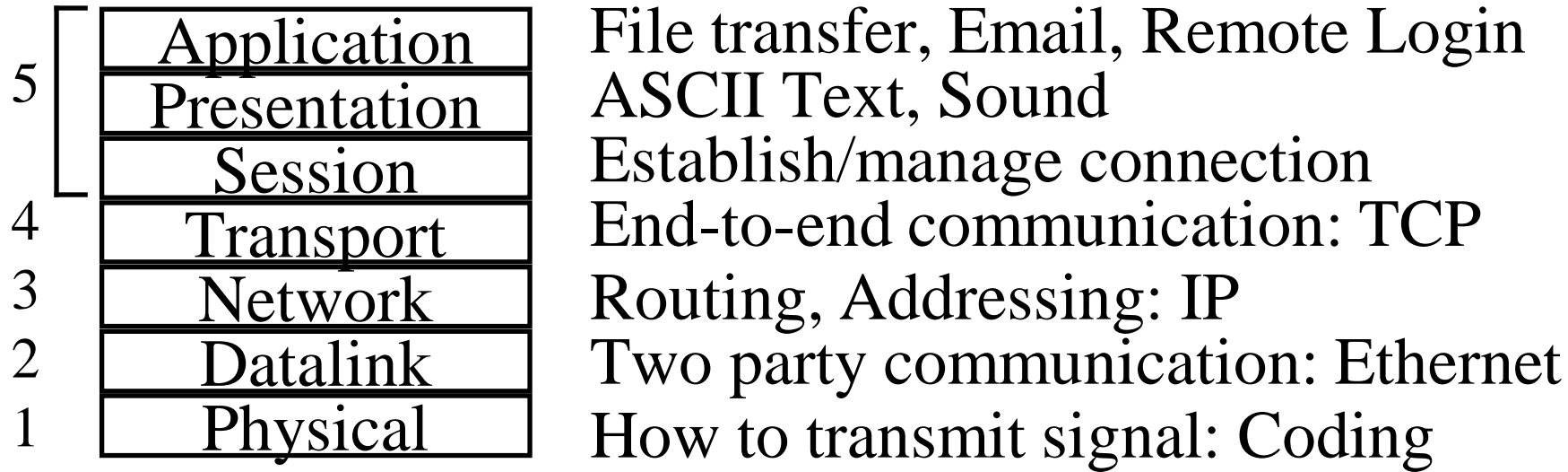

## Student Questions

- Layer 2 and Layer 4 sound pretty similar to me. Both of them focus on communication. Could you help me distinguish them?

*One link vs. one path*

*A path has many links on the way. The same functions require different solutions since the latencies are different.*

- Would you clarify what the data link and session levels are responsible for?

*Data link = One link*

*Session = One application*

- Is there an example of a "Session protocol" or is that not a thing at all?

*Mail and HTTP are examples of applications. In TCP, application, presentation, and session layers are combined as one.*

- What layers connection does "ping" check? Sometimes we can ping a website, but we cannot see the content of the website in the browser. *Layer 3*
- Are layers interconnecting with each other before communicating? *As soon as a layer has been initialized, it is ready to talk.*

# ISO/OSI Reference Model

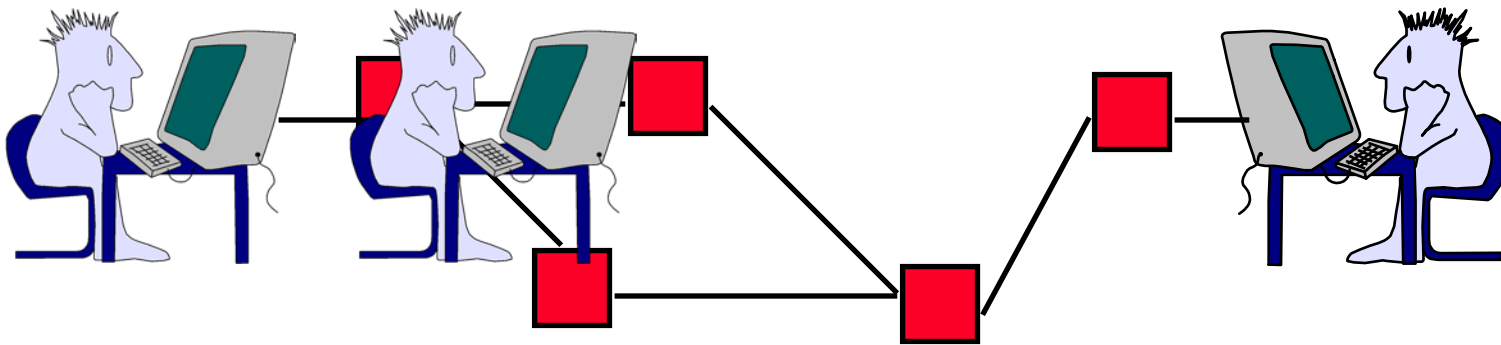
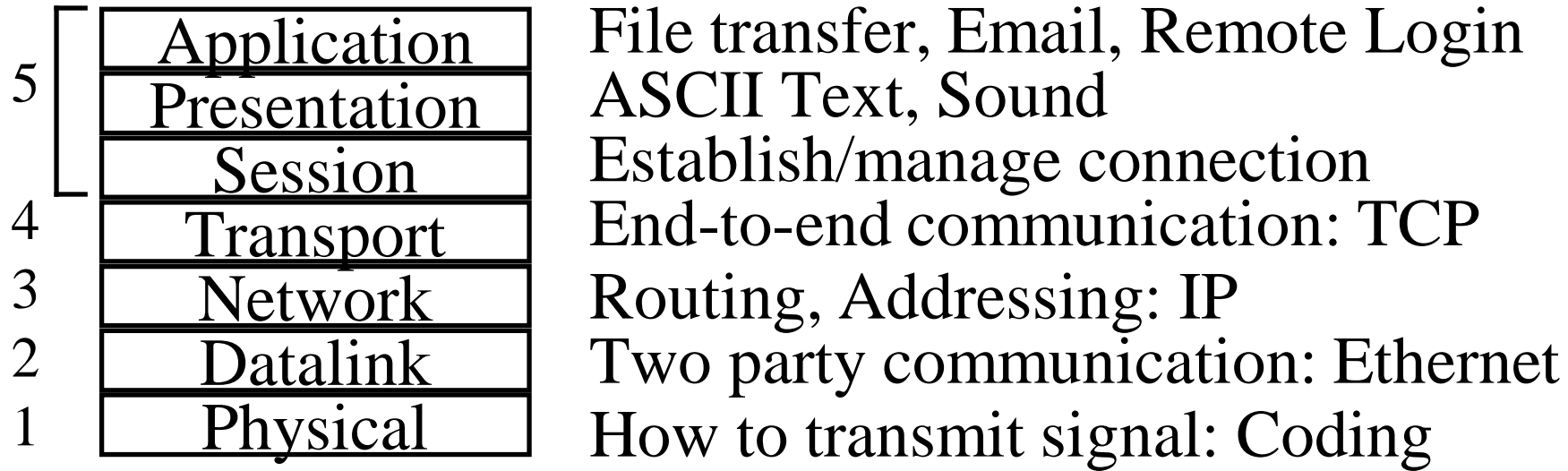

## Student Questions

- Is there any specific order for the layers? For example, the session layer has to be before the transport layer. *Yes.*
- Is combining or separating the application, presentation, and session layer dependent on the protocol?

*Yes. TCP combines all of these.*

- Should we see the model top to bottom or bottom to top?

*This textbook covers top-down. Other books cover bottom-up.*

- In a modern server, which layers are handled by the operating system?

*Up to Layer 4.*

- Layer 5 was composed of application, presentation, and session. Is there any connection between them?

*Yes. It all depends on the application.*

- Which layers of OSI is the router we use on?

*Layer 3.*

- Where can we get the handout?

*Course website:*

<http://www.cse.wustl.edu/~jain/cse473-23/index.html>

# ISO/OSI Reference Model

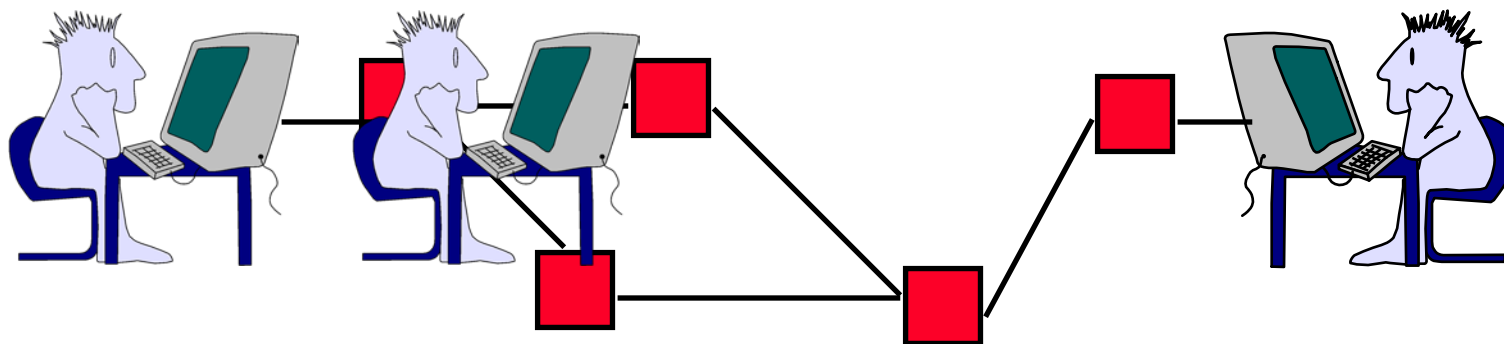
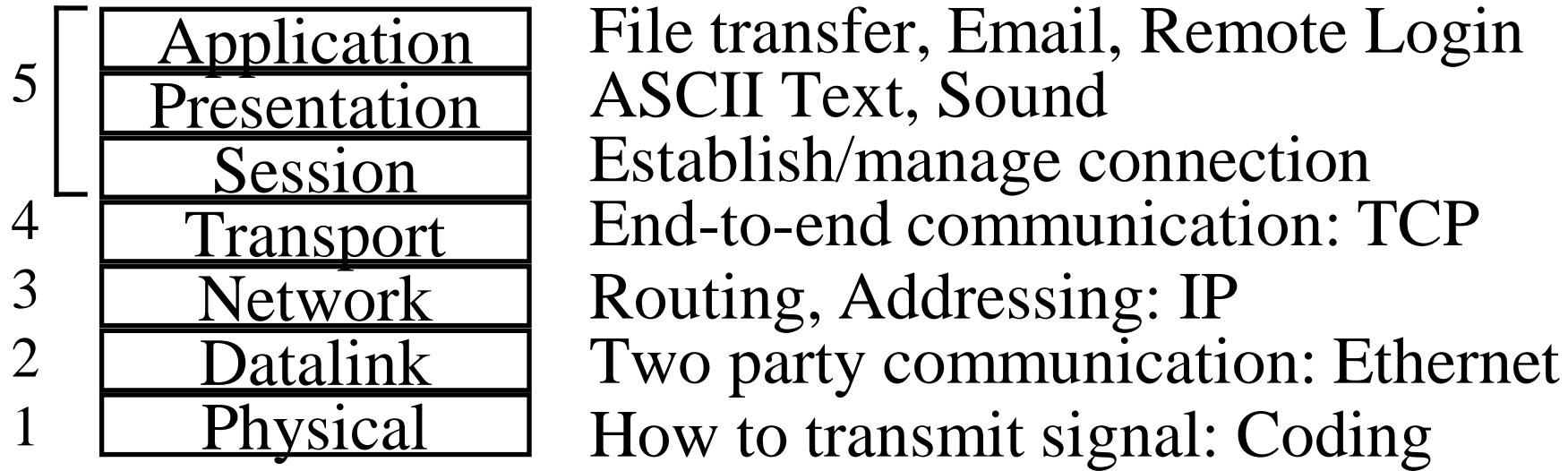

## Student Questions

- Since the transport layer does end-to-end communication, what does the network layer do?

*Find the path (Routing)*

- Does this 5-layer model have any connection with the 4-layer TCP/IP model?

*They are same. 1+2 might be combined.*

- Why is the ISO model taught instead of the TCP/IP model? Is it just easier to understand?

*It is also used in many topics.*

- Why are layers 5, 6, and 7 grouped?

*They are tightly connected.*

- Why is the 5<sup>th</sup> layer designed with 3 components? What made them design it like this?

*They are tightly connected.*

# Service and Protocol Data Units

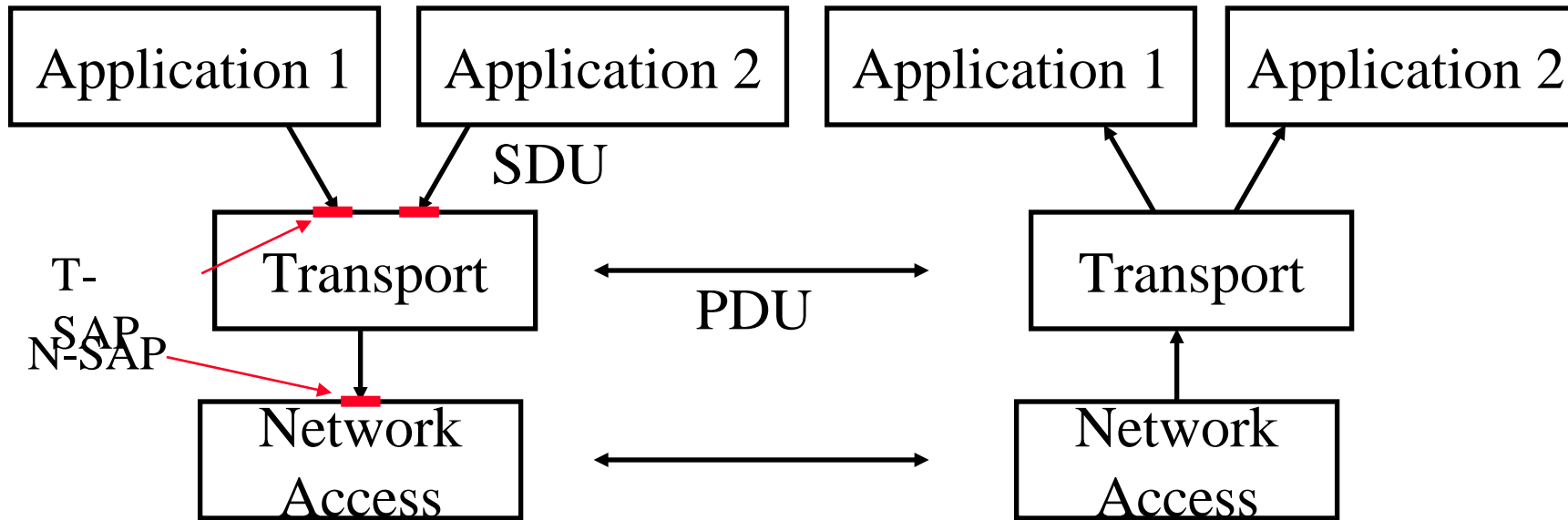

- ❑ Service Access Points (SAPs)
- ❑ Service Data Units (SDUs)
- ❑ Protocol Data Units (PDUs)

## Student Questions

- ❑ What are Service Access Points (SAPs)?  
*See the updated figure on the left.*  
*Ports are examples of T-SAPs (Transport SAPs)*
- ❑ Could SAP be described as an API of a different layer?  
*Yes. SAP=API of a layer.*
- ❑ You said SDU goes down vertically over the layer, and PDU goes horizontally over the same layers. But I remember the procedure of data transmission is to first go down to the physical layer, the router, then the physical layer of another host when it finishes. This is contradicted by what the slide refers to. Could you explain?  
*You are right. The PDUs are units of information exchanged by modules of one layer. But they have to go down vertically, travel horizontally, then vertically up.*
- ❑ Do the arrows between Transport and Network Access imply that Transport PDUs are bidirectional while Network PDUs are not?

*Corrected.*

# Service and Protocol Data Units

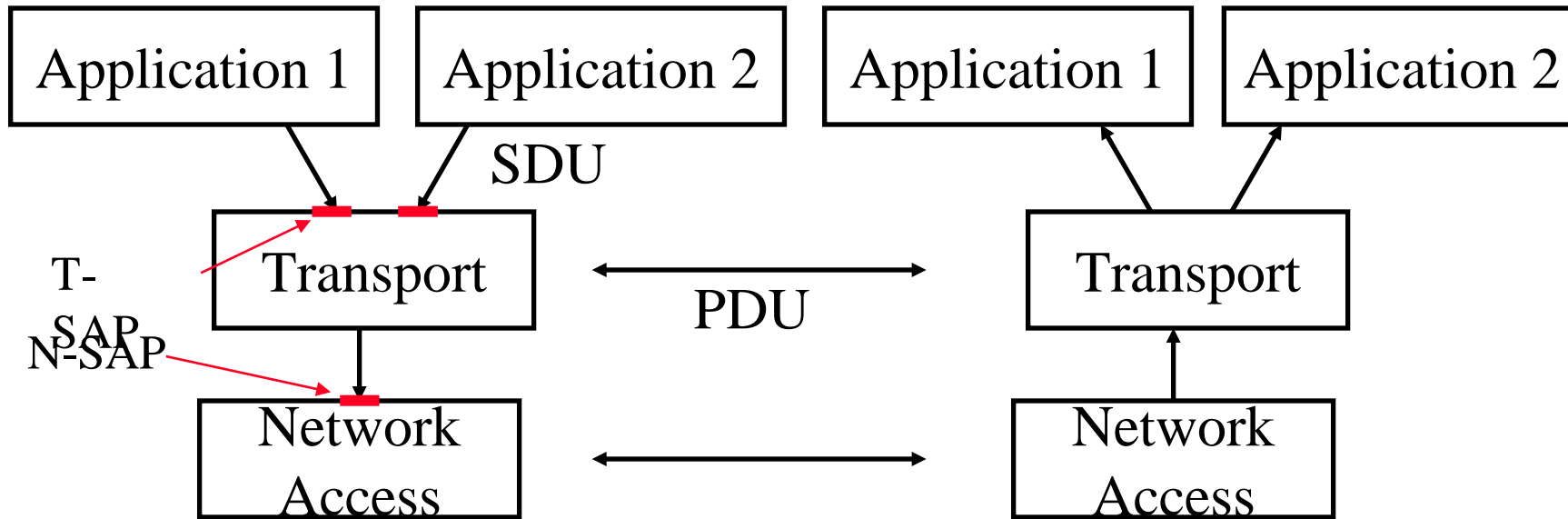

Service Access Points (SAPs)

Service Data Units (SDUs)

Protocol Data Units (PDUs)

## Student Questions

- Do the arrows between Transport and Network Access imply that Transport PDUs are bidirectional while Network PDUs are not? *Corrected.*
- Can you explain more about how PDU works? What do you mean PDU goes horizontally?

*In the same layer, e.g., layer 3 to layer 3.*

- Are PDUs and SDUs just simple bits? Or are they packets?

*They are packets*

- In the diagram, why are there PDUs on the T and N layer but not on any other

*They apply to all layers.*

- Can you give an example of a PDU needing to be used?

*PDUs are packets.*

- Does data unit mean packet? And is the service data unit vertical, and is the protocol data unit horizontal? *Yes.*
- What is the difference between SAP and SDU? And what do they do each?

*SDUs are packets. Packets enter through Service access points.*

# Service and Protocol Data Units

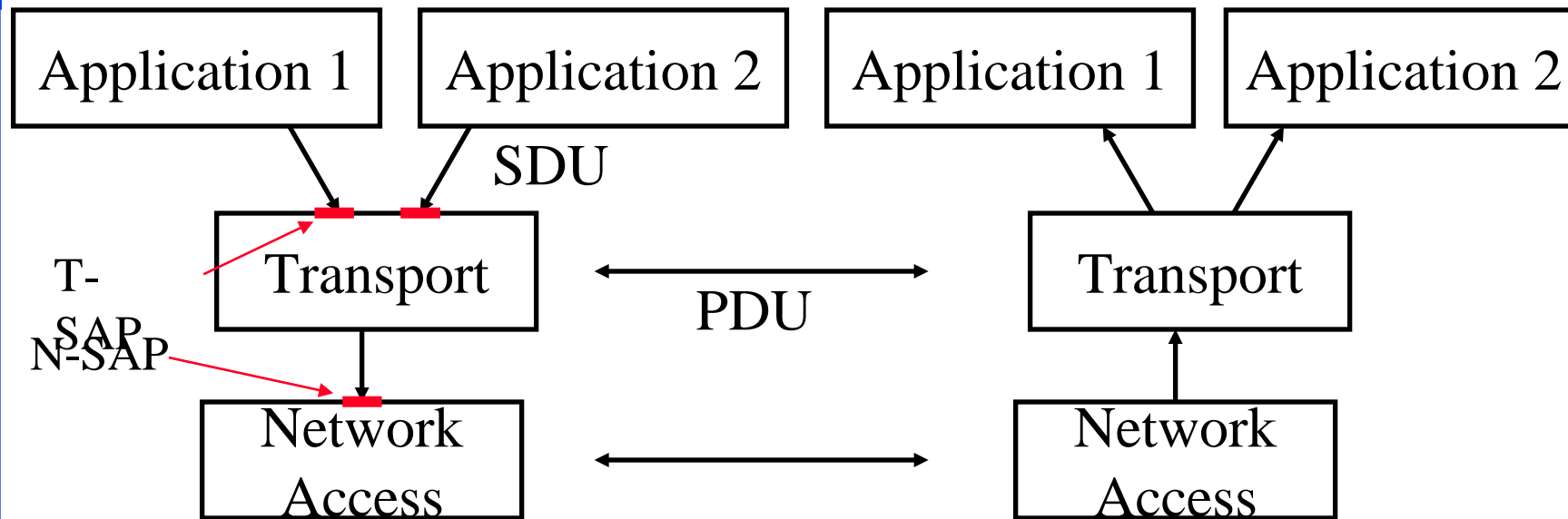

Service Access Points (SAPs)

Service Data Units (SDUs)

Protocol Data Units (PDUs)

## Student Questions

- Why do protocols need to split data into SDUs and PDUs?

*All delivery services have predefined limits on boxes.*

- What are the advantages of this layered structure?

*Each layer can be designed and operated independently.*

# Service Data Unit (SDU)

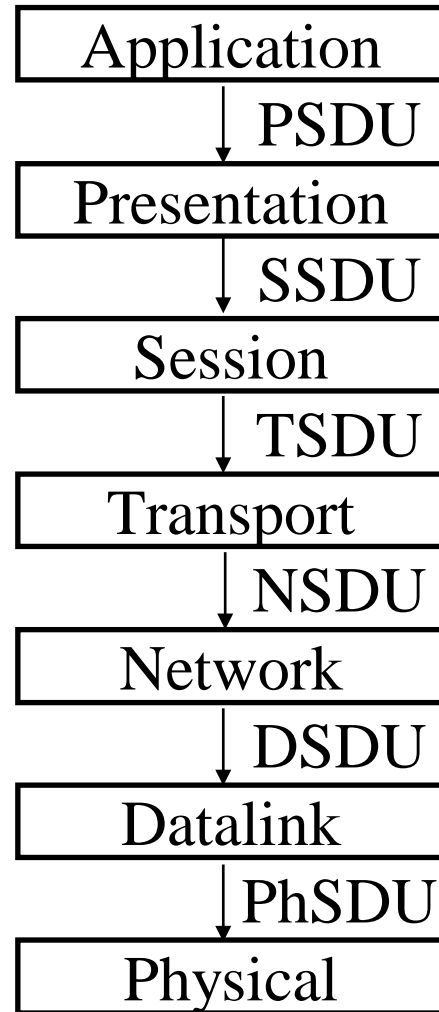

## Student Questions

- ❑ Can a layer communicate only with layers directly above and below it, or can it skip layers?

*In a strictly layered architecture, the communication is between successive layers only. Although not common, cross-layer communication has been studied and applied to some special situations.*

- ❑ Are the SDU and PDU for each layer different actual bit patterns? Is the incoming SDU translated into a PDU for that protocol layer, which is then translated to the SDU for the next layer and transmitted?

*Yes, SDUs and PDUs are different for different layers. PDUs are formed by combining or fragmenting SDUs. Each PDU has a header that is understood by the other side.*

- ❑ For PDU, does one layer send data directly to another similar layer, or just transmit to the bottom layer vertically, then send in the physical layer, and finally go up vertically to the target layer?

*Yes. PDUs go to the bottom layer and then across.*



# Service Data Unit (SDU)

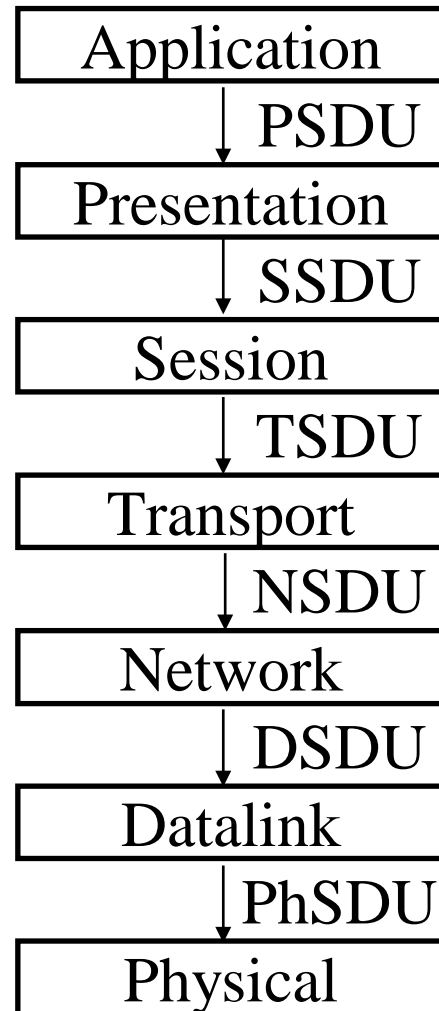

## Student Questions

- Why can't they just use one type of data unit to unify SDU and PDU?  
*They are different.*
- Are the names the same if they are being passed up the ladder?

*Yes*

- 
- Do packets typically get routed through multiple layers of the internet? Is there different delay amounts for each level of the internet or are they all roughly the same?

*Delays on the wire are much much larger than those inside the system.*

# Protocol Data Unit (PDU)

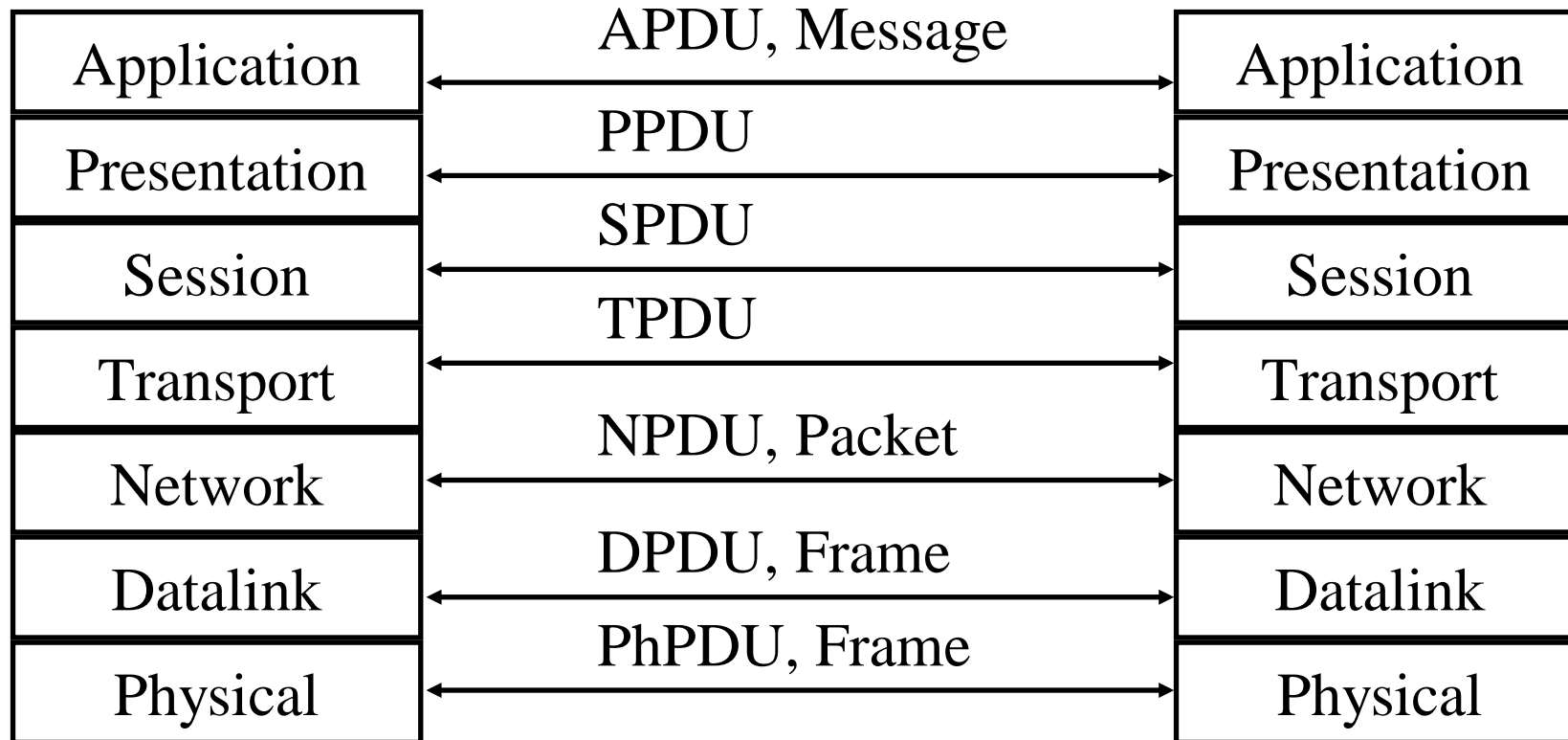

## Student Questions

- ❑ What is the difference between SDUs and PDUs?

*Service data units go down vertically between different layers.*

*Protocol data units flow horizontally between the entities in the same layer.*

- ❑ If a message must go down through all the layers before being transmitted, why do layers besides the lowest one have PDUs?

*Each has a format that is understood only by that layer.*

- ❑ Do both PDUs and SDUs follow TCP/IP.

*PDU/SDU terminology can be used with TCP/IP also but it is used more in non-IETF protocols.*

- ❑ Can you please explain SDUs and PDUs in more detail and what is the responsibility of each layer?

*Sure.*

# TCP/IP Reference Model

TCP = Transmission Control Protocol

IP = Internet Protocol (Routing)

TCP/IP Ref Model

Application
Transport
Internetwork
Host to Network
Physical

TCP/IP Protocols

FTP	Telnet	HTTP
TCP		UDP
IP		
Ethernet	Point-to-Point	Packet Radio
Coax	Fiber	Wireless

## Student Questions

- ❑ TCP is "Transmission Control Protocol" and IP is "Internet Protocol", is "TCP/IP Protocol" not good since "Protocol" is repeated?

*TCP/IP is a "protocol suite."*

- ❑ What is the V for in IPV?

*IPv4 = IP version 4*

*IPv6 = IP version 6*

# OSI vs TCP/IP

OSI	TCP/IP
Application	Application
Presentation	
Session	
Transport	Transport (host-to-host)
Network	Internet
Data Link	Network Access
Physical	Physical

## Student Questions

- How is the session layer from the OSI model split up between the application and transport layers of the TCP/IP model?

*Some functions of the session layer are in TCP, and some are not. It doesn't really matter since TCP is now universal, along with a few other similar transports.*

- What is the difference between the OSI model and the TCP/IP model? I've looked at so many different websites' explanations but still don't understand...

*OSI was done after TCP/IP. However, by the time OSI was partially completed, TCP/IP was universally implemented. So OSI is more methodical but nonexistent. TCP/IP is less methodical but everywhere.*

- Should we be comfortable with both the OSI and TCP/IP models, or is it sufficient to only be comfortable with the TCP/IP model?

*You should know as much about the OSI model as discussed in this class video and Q&As.*

- Is the TCP/IP model used now, and the OSI model is obsolete? **Yes.**

# OSI vs TCP/IP

OSI	TCP/IP
Application	Application
Presentation	
Session	
Transport	Transport (host-to-host)
Network	Internet
Data Link	Network Access
Physical	Physical

## Student Questions

- ❑ Can I say that the OSI model distinguishes the session layer and application layer, but from a real-world programmer point of view, sessions are part of the application layer?

*Real-world applications need particular session layer functions and cannot run on different layers.*

- ❑ Is OSI still used in any places?  
*Many OSI protocols and OSI terms are still helpful and used.*

- ❑ What are the key differences in layer functionality between the OSI model and the TCP/IP model, and how do these differences affect the design and implementation of network protocols?

*This slide shows the differences. Different organization work on different layers.*

# OSI vs TCP Reference Models

- ❑ OSI introduced concept of services, interface, protocols. These were force-fitted to TCP later  
⇒ It is not easy to replace protocols in TCP.
- ❑ In OSI, reference model was done before protocols. In TCP, protocols were done before the model
- ❑ OSI: Standardize first, build later  
TCP: Build first, standardize later
- ❑ OSI took too long to standardize. TCP/IP was already in wide use by the time.
- ❑ OSI became too complex.
- ❑ TCP/IP is not general. Ad hoc.

## Student Questions

- ❑ Does there not need to be one agreed-upon model among all telecommunication services/companies?  
*Everyone's needs are different.*
- ❑ What happens when a host detects packet loss?

*It may ask the source to retransmit.*

---

# PDU in TCP/IP Architecture

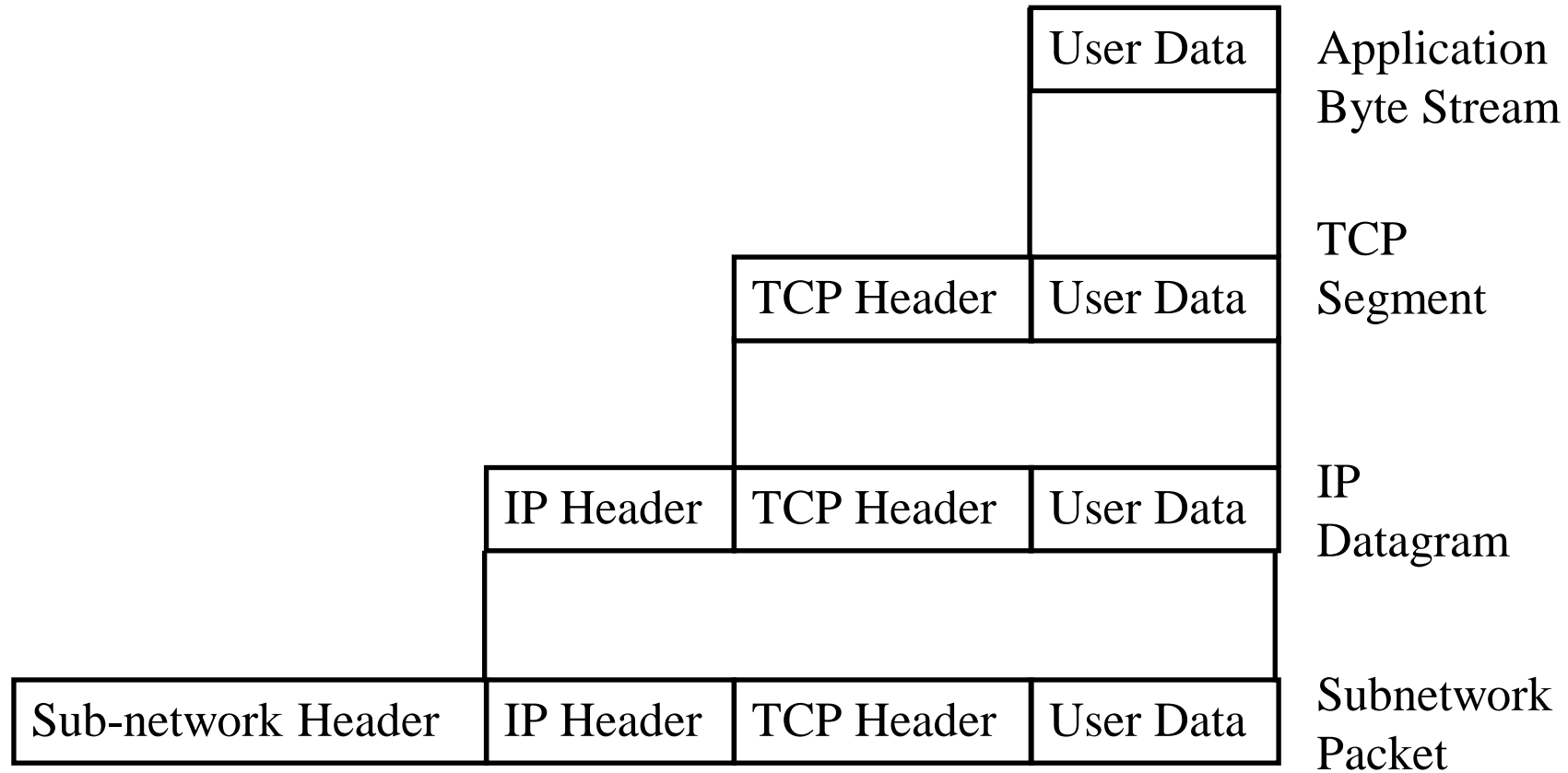

## Student Questions

- If the TCP is not full yet, can it still send the message? *Yes, based on a timer.*
- What does header mean?  
*The header contains information that the other side needs.*
- Are headers attached to data when it travels down the network layers? *Yes.*
- Is there ever encryption between any of these steps?  
*Encryption is usually done in the end-to-end (transport) layer.*

- 
- Is there footers often? or how does the software determine when they reach the end of their portion?  
*Headers have a length field or well defined format. Trailers are used in some protocols at the end of the packet to provide error correction.*



# TCP/IP Applications

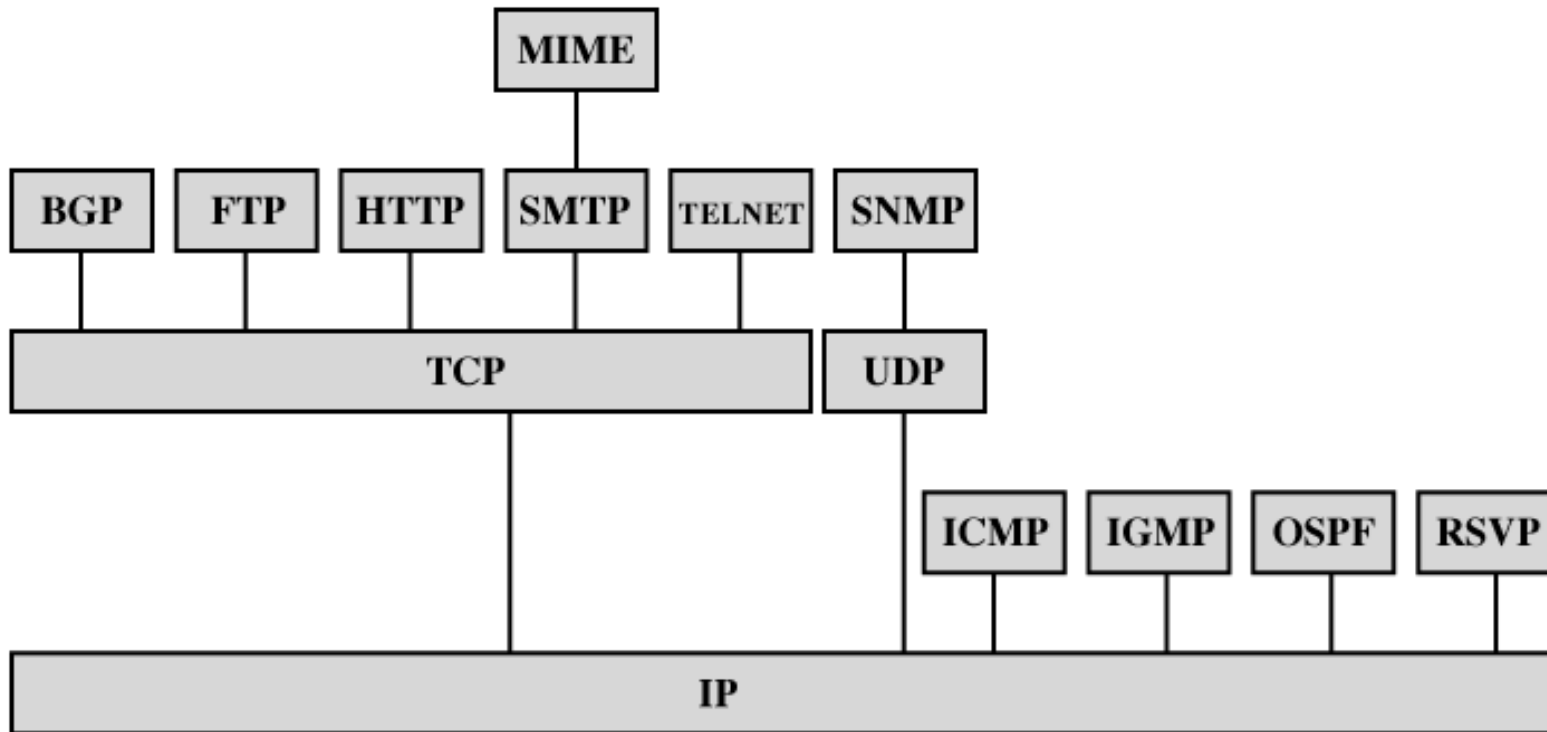

BGP = Border Gateway Protocol  
FTP = File Transfer Protocol  
HTTP = Hypertext Transfer Protocol  
ICMP = Internet Control Message Protocol  
IGMP = Internet Group Management Protocol  
IP = Internet Protocol  
MIME = Multi-Purpose Internet Mail Extension

OSPF = Open Shortest Path First  
RSVP = Resource ReSerVation Protocol  
SMTP = Simple Mail Transfer Protocol  
SNMP = Simple Network Management Protocol  
TCP = Transmission Control Protocol  
UDP = User Datagram Protocol

## Student Questions

- Will we be expected to memorize all of these protocols and if they run on TCP/IP/SMTP/etc.?

*Not yet. However, in later modules, we cover some of these protocols. Then you will need to know what runs below and above. This is just a preview and lists too many protocols.*

- Is it correct that because the HTTP layer is above TCP, it is responsible for giving the TCP layer the properly formatted message? *Yes.*
- As shown in the figure, Is TCP included in IP? *No. It uses IP.*

- 
- Does MPI run on TCP, UDP, or IP? Are there better protocols (than MPI) for clusters and distributed computing?

*Message Passing Interface (MPI) is used in high-performance computing for inter-process communication. It can run w or wo TCP/IP.*

# Network Security

- ❑ Security Components
- ❑ Types of Malware
- ❑ Types of Attacks
- ❑ Buffer Overflows
- ❑ Distributed DoS Attacks

## Student Questions

- ❑ In my background, I found any attack on any part of an arbitrary company's security system starts with loading up the main site and seeing what's publicly available to look at. Checking the place out often leads to best-case some goal achieved and worst-case information useful for an exploit, I have heard at times and in places before. Why wouldn't simply looking around be the first step of an arbitrary attack, network security-related or otherwise?

*Snooping is the first step of an attack.*

---

# Security Components

- ❑ **Confidentiality**: Need access control, Cryptography, Existence of data
- ❑ **Integrity**: No change, content, source, prevention mechanisms, detection mechanisms
- ❑ **Availability**: Denial of service attacks,
- ❑ Confidentiality, Integrity and Availability (**CIA**)



## Student Questions

- ❑ Does maintaining a security component (e.g., integrity) require the knowledge of the result (e.g., file has been verified with a checksum), or is it enough to know that you have enacted countermeasures and you have not detected any tampering?

*Maintaining a component requires that that component be verified and ensured.*

- ❑ So Confidentiality is controlling the audience, Integrity is controlling the contents, and Availability is maintaining the speaker's voice. Is that a reasonable comparison?

*Controlling is stronger than “no change.” Maintaining is not the same as availability.*

# Types of Malware

- ❑ **Viruses:** Code that *attaches* itself to programs, disks, or memory to propagate itself.
- ❑ **Worms:** Installs copies of itself on other machines on a network, e.g., by finding user names and passwords
- ❑ **Trojan horses:** Pretend to be a utility. Convince users to install it on their PC.
- ❑ **Spyware:** Collect personal information
- ❑ This is not a complete list.

## Student Questions

- ❑ Worms and viruses don't sound mutually exclusive based on the definitions given. The difference is only in how they arrive on your system?

*Yes, viruses can fly but worms can only walk.*

- ❑ Can viruses or worms be transported through trojan horses?

*Yes.*

- ❑ These are not mutually exclusive, right? A piece of malware could be any/all of these.

*Yes. A virus could be spyware.*

- 
- ❑ What's the difference between a virus and a worm?

*Virus comes from installed programs. Worms come by walking in through the network.*

# Types of Attacks

- ❑ **Denial of Service (DoS):** Flooding with traffic/requests
- ❑ **Buffer Overflows:** Error in system programs. Allows hackers to insert their code into a program.
- ❑ **Malware**
- ❑ **Brute Force:** Try all passwords.
- ❑ **Port Scanning:**  
⇒ Disable unnecessary services and close ports
- ❑ **Network Mapping**

## Student Questions

- ❑ How would you protect against something like a Buffer Overflow attack on the network layer?

*Good code writing.*

- ❑ How to do port scanning?  
*We will show you later in the security chapter.*

- ❑ Are DDoS attacks common on popular sites like YouTube? Are they effective?

*Yes. Yes.*

- ❑ Are there other types of DoS attacks that are not DDoS?

*Attacks from a single node to a single node are non-DDoS.*

- 
- ❑ Will we also learn ways to prevent these DoS attacks?

*Chapter 8 on security covers some of the attacks. More in a security course.*

- ❑ Is network mapping why ping isn't enabled on computers by default? *Yes*

# Types of Attacks

- ❑ **Denial of Service (DoS):** Flooding with traffic/requests
- ❑ **Buffer Overflows:** Error in system programs. Allows hackers to insert their code into a program.
- ❑ **Malware**
- ❑ **Brute Force:** Try all passwords.
- ❑ **Port Scanning:**
  - ⇒ Disable unnecessary services and close ports
- ❑ **Network Mapping**

## Student Questions

- ❑ What exactly is port scanning and why is it generally the first step in network attacking?  
*Ports will be defined in Chapter 3 on TCP.*

# Distributed DoS Attacks

- ❑ **Tribe Flood Network** (TFN) clients are installed on compromised hosts.
- ❑ All clients start a simultaneous DoS attack on a victim on a trigger from the attacker.
- ❑ **Trinoo** attack works similarly. Use UDP packets. Trinoo client report to Trinoo master when the system comes up.
- ❑ **Stacheldraht** uses handlers on compromised hosts to receive encrypted commands from the attacker.

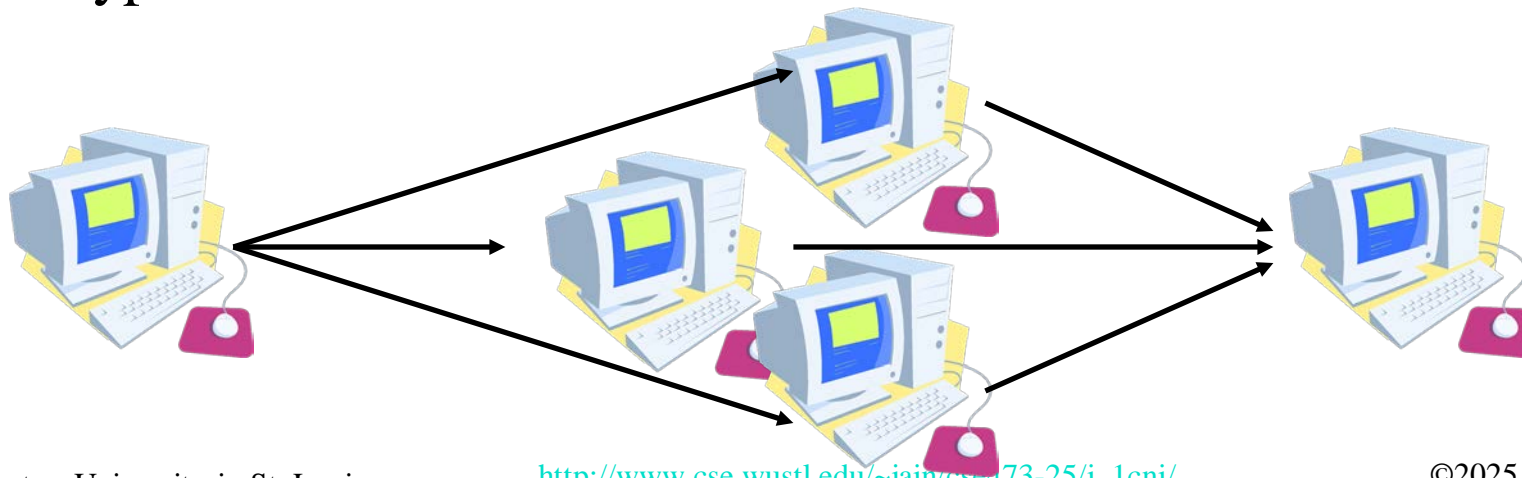

## Student Questions

- ❑ How does the Stacheldraht attack differ from TFN and Trinoo?

*Similar but different programs.*

- ❑ What mechanisms do Distributed Denial of Service (DDoS) attacks employ, and what strategies can be implemented to mitigate their effects?

*Mechanism briefly shown in the figure. Solutions to be discussed in Chapter 8.*



# History of Internet

- ❑ 1961: Kleinrock developed queueing theory. Showed effectiveness of packet-switching
- ❑ 1964: Baran's report on packet-switching in military nets
- ❑ 1967: ARPAnet conceived by Advanced Research Projects Agency
- ❑ 1969: First ARPAnet node operational  
First Request for Comment (RFC)  
[www.ietf.org](http://www.ietf.org)

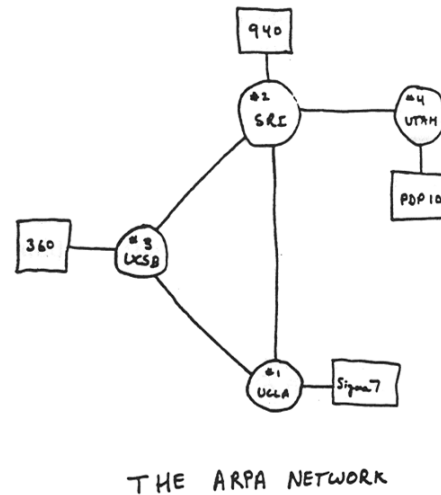

## Student Questions

- ❑ What is the ARPA Network diagram showing? What is 360, 940 etc.

*ARPA=Advanced Research Project Agency = Military research  
IBM-360, IBM-940 are computers.  
This is the picture of the baby Internet at birth.*

# History of Internet (Cont)

- ❑ Early 1990s: HTML, HTTP: Berners-Lee
- ❑ 1994: Mosaic, later Netscape
- ❑ 2007:
  - ~500 million hosts
  - Voice, Video over IP
  - P2P applications: BitTorrent (file sharing), Skype (VoIP), PPLive (video)
  - Video applications: YouTube, gaming
  - Wireless, Mobility

## Student Questions

- ❑ It seems like the internet is Point to Point.  
Is this true?

*No. In some places, it is broadcast, e.g., in Wi-Fi.*

---

# Key Concepts

- ❑ **Internet Protocol (IP):** Protocol
- ❑ **Address:** All systems have an IP address, for example, 125.36.47.23
- ❑ **Name:** All systems have a human-readable name, e.g., scorpio.cec.wustl.edu, ibm.com.
- ❑ Technically called **DNS (domain name systems)** name. Details will be introduced later.
- ❑ **IETF:** Internet Engineering Task Force. Make standards for the Internet. IETF.org
- ❑ **RFC:** Request for comments. Documents that describe Internet protocols.

## Student Questions

- ❑ Are IP addresses and names identical?  
*Not identical. They are related.*
  - ❑ What is the difference between IPv4 and IPv6?  
*Version 4 and Version 6.*
  - ❑ How do you convert from DNS to IP?  
*See Chapter 2.*
  - ❑ What exactly is the difference between a name and a domain name?  
*The domain name is a standardized format of names for networking nodes.*
  - ❑ Are we sticking to IPv4 for this course, or are we going to discuss IPv6 as well?  
*Mostly IPv4. IPv6 briefly.*
  - ❑ Are IPv6 addresses also all 8-bit numbers?  
*128-bit*
-

# Summary

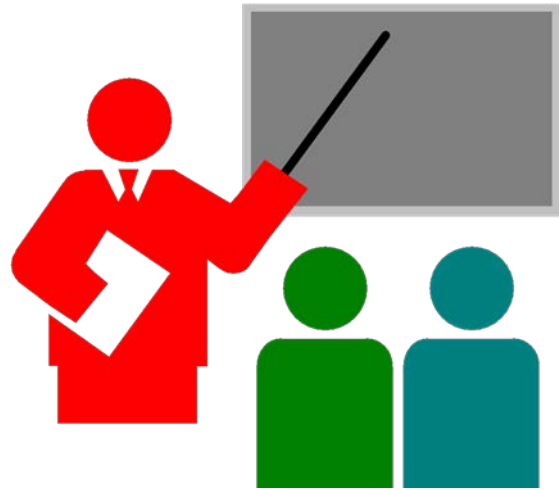

- ❑ The most common medium is **UTP**, wireless, fiber
- ❑ **The Internet** is a network of networks
- ❑ Enterprise, **access**, and **core** networks
- ❑ Performance Measures: **Delay**, **Throughput**, **Loss Rate**
- ❑ Protocol Layers: **ISO** and **TCP/IP** reference models

Ref: Read entire Chapter 1 and try R1-R28 8<sup>th</sup> Edition.

## Student Questions

- ❑ Is homework due before class or after class, or do we have some time?  
*Homework is due at 1 PM on the due date.*
- ❑ Why is ipv6 so scarcely used?  
*Old habits die hard. Too much deployed equipment.*
- ❑ Are the Enterprise networks the Stub networks we discussed in the previous lecture?

*Yes*

---

# Lab 1: Internet and Wireshark

[6 points]

1. Find the IP address of your computer (ipconfig, ifconfig)
2. Find the IP address of www.wustl.edu (ping)
3. Measure the delay from your computer to www.wustl.edu (ping or tracert)

For all cases, submit the screen snapshot showing the command used and the output. (Use Alt-Print-screen to capture a window to the clipboard and then paste it to word)

## Student Questions

- How do you measure the delay from a computer to a website? What is tracert?  
*Type these commands in a Windows command prompt box and see what happens. E.g., try 'tracert www.wustl.edu'*

*They work similarly in Mac and Linux.*

- What do you mean by the internet address of google there? Do you mean the IP address?

*Yes.*

- Is it all right if we use a snipping or other screenshot tools, or do you need a full screenshot?

*Snipping tools are OK.*

- How is the number of hops determined by tracert?

*By counting the number of routers on the path.*

- I downloaded wireshark but have no idea what to do with it. Is it possible for you to go over that a little bit more?

*First, become familiar with various functions. Then start logging. Go to another window and start Tracert. Come back and stop logging. Look at the log.*

# Lab 1 (Cont)

## 4. Download Wireshark,

<https://www.wireshark.org/download.html>

- Install it on your laptop.
- If you are using a windows computer, you will also need npcap (Packet Capture Tool) from nmap.org.
- Start Wireshark and start logging.
- **Tracert** to [www.google.com](http://www.google.com)
- Stop logging. Capture the current screen and submit. Do not worry about the part of the trace that is no longer on the screen.
- Q1: List 3 protocols that you see in the packet trace.
- Q2: What is the internet address of [www.google.com](http://www.google.com) from the trace?

Please see Slide 1-63 for additional hints on this lab

## Student Questions

- ❑ Is tracert the same as "ping"? Should we use "traceroute" on Mac?

*Tracert is different than ping. Yes, It is called traceroute on Mac.*

# Reading List

- ❑ Read Chapter 2 of the textbook for the next class.

## Student Questions

# Acronyms

APDU	Application Packet Data Unit
ARPAnet	Advanced Research Project Agency Network
ASCII	American Standard Code for Information Interchange
AT&T	American Telephone and Telegraph
CBR	Constant Bit Rate
CIA	Confidentiality, Integrity, Access
DNS	Domain Name Service
DoS	Denial of Service
DPDU	Datalink Packet Data Unit
DSDU	Datalink Service Data Unit
DSL	Digital Subscriber Line
FDM	Frequency Division Multiplexing
FTP	File Transfer Protocol
FTTH	Fiber to the host
GHz	Giga Hertz
HFC	Hybrid Fiber Coax

## Student Questions

- Do we need to remember all Acronyms? Even if some are e not mentioned in the slide at all?

*At least those that are mentioned in the slides or in the book.*

---



# Acronyms (Cont)

HTML	Hyper-Text Markup Language
HTTP	Hyper-Text Transfer Protocol
IEEE	Institution of Electrical and Electronics Engineers
IETF	Internet Engineering Task Force
IP	Internet Protocol
ISO	International Standards Organization
ISP	Internet Service Provider
kHz	Kilo Hertz
LAN	Local Area Network
LTE	Long Term Evolution
MAN	Metropolitan Area Network
MHz	Mega Hertz
NPDU	Network Protocol Data Unit
NSDU	Network Service Data Unit
OSI	Open System Interconnect
PC	Personal Computer

## Student Questions

# Acronyms (Cont)

PDU	Protocol Data Unit
PhSDU	Physical Service Data Unit
PON	Passive Optical Network
PPDU	PHY protocol data unit
PSDU	PHY Service data unit
RFC	Request for Comments
SAPs	Service Access Points
SDU	Service Data Units
SPDU	Session Protocol Data Unit
SSDU	Session Service Data Unit
STP	Shielded Twisted Pair
TCP	Transmission Control Protocol
TDM	Time Division Multiplexing
TFN	Tribe Flood Network
TP	Twisted Pair
TSDU	Transport Service Data Unit

## Student Questions

# Acronyms (Cont)

TV	Television
UDP	Universal Data Protocol
UTP	Unshielded Twisted Pair
VoIP	Voice over IP
WAN	Wide Area Network
WiFi	Wireles Fidelity

## Student Questions

# Scan This to Download These Slides



Raj Jain

<http://rajjain.com>

[http://www.cse.wustl.edu/~jain/cse473-25/i\\_1cni.htm](http://www.cse.wustl.edu/~jain/cse473-25/i_1cni.htm)

## Student Questions

- Do we still use broadcast technology in today's world, or is it directed?

*Wireless is mostly broadcast.*

- For the circuit, does it mean if I want to connect to Amazon, Amazon has to be online first, then we can build the connection and talk?

*Yes.*

- Which types of networks are more common, and how can they be identified?

*Please wait till you learn about different network technologies.*

- Is it better to watch the video first and then the teaching material, or is it better to watch the teaching material first and then watch the video?

*Watch the video and keep the slides to write down the questions for later reference.*

- Will OFDM be introduced in this course?  
*Yes, in the wireless Chapter 7.*

# Scan This to Download These Slides



Raj Jain

<http://rajjain.com>

[http://www.cse.wustl.edu/~jain/cse473-25/i\\_1cni.htm](http://www.cse.wustl.edu/~jain/cse473-25/i_1cni.htm)

## Student Questions

- The video ends on slide 19. Can I ask questions about slide 22?  
*It will be answered in the next video when we get to that slide.*
- There were 102 slides, but this questionnaire only showed 70.  
*Please use the slide numbers in the bottom left of the slide.*
- I had trouble submitting the Google form with my university email, so I used Gmail.  
*If many people have this problem, we must register everyone's Gmail.*
- Is this required if we had questions on specific slides instead? Also the dates and weekdays do not line up in the class calendar

# Scan This to Download These Slides



Raj Jain

<http://rajjain.com>

[http://www.cse.wustl.edu/~jain/cse473-25/i\\_1cni.htm](http://www.cse.wustl.edu/~jain/cse473-25/i_1cni.htm)

## Student Questions

- Is “Any other questions or issues with this module” required if we had questions on specific slides instead?

*No it is not required.*

- Also the dates and weekdays do not line up in the class calendar.

*I will check it. Please point out specific errors.*

- How does the Domain Name System (DNS) convert a domain name like wustl.edu into an IP address?

*Discussed in the next chapter.*

# Related Modules



CSE 567: The Art of Computer Systems Performance Analysis  
[https://www.youtube.com/playlist?list=PLjGG94etKypJEKjNAa1n\\_1X0bWWNyZcof](https://www.youtube.com/playlist?list=PLjGG94etKypJEKjNAa1n_1X0bWWNyZcof)

CSE473S: Introduction to Computer Networks (Fall 2011),

[https://www.youtube.com/playlist?list=PLjGG94etKypJWOSPMh8Azcg5e\\_10TiDw](https://www.youtube.com/playlist?list=PLjGG94etKypJWOSPMh8Azcg5e_10TiDw)



CSE 570: Recent Advances in Networking (Spring 2013)

<https://www.youtube.com/playlist?list=PLjGG94etKypLHyBN8mOgwJLHD2FFIMGq5>

CSE571S: Network Security (Spring 2011),

<https://www.youtube.com/playlist?list=PLjGG94etKypKvzfVtutHcPFJXumyyg93u>



Video Podcasts of Prof. Raj Jain's Lectures,

<https://www.youtube.com/channel/UCN4-5wzNP9-ruOzQMs-8NUw>

## Student Questions

# Lab 1: Hints

The HTTP traffic may not show in Wireshark if:

You may not have installed npcap

You may not be using Tracert. Do not use HTTP for this lab.

2. The websites you are doing your test on use HTTPS (TLS). In this case, Wireshark will identify the protocol as a TLS packet, not an HTTP packet.

3. If you are using Chrome, Edge, or any browser based on Chromium engine, the traffic when accessing google.com will show as QUIC because Google uses QUIC for their websites. Also, this is valid for other websites that use QUIC.

If you want to see the content of A TLS packet, follow this guide:

<https://wiki.wireshark.org/TLS#:~:text=Step-by-step%20instructions%20to%20decrypt%20TLS%20traffic%20from%20Chrome,from%20step%202%20is%20created.%20More%20items...%20>

## Student Questions