

# Computer Networks and the Internet

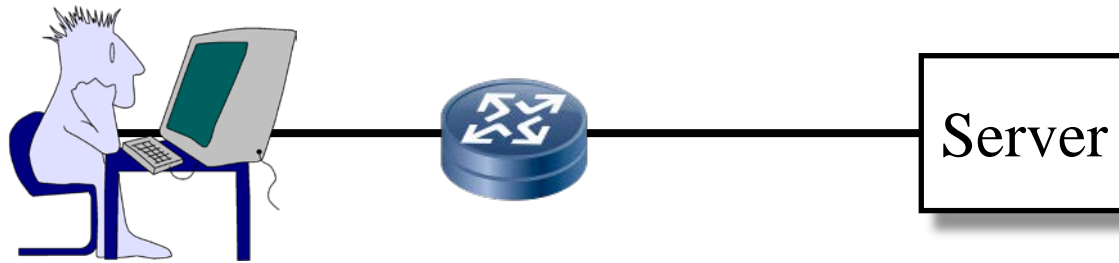

**Raj Jain**

Washington University in Saint Louis

Saint Louis, MO 63130

Jain@wustl.edu

Audio/Video recordings of this lecture are available on-line at:

<http://www.cse.wustl.edu/~jain/cse473-22/>

**Student Questions**



1. What is Internet?
2. Switching: Circuit vs. Packet
3. Edge vs. Core
4. Network Performance Measures: Delay, Loss, Throughput
5. Protocol Layers
6. Network Security
7. History

**Note:** This class lecture is based on Chapter 1 of the textbook (Kurose and Ross) and the slides provided by the authors.

## Student Questions

# What is a Network?

- ❑ **Network:** Enables data transfer among nodes
  - Generally heterogeneous nodes
  - More than **two** nodes
  - E.g., Your home or office network

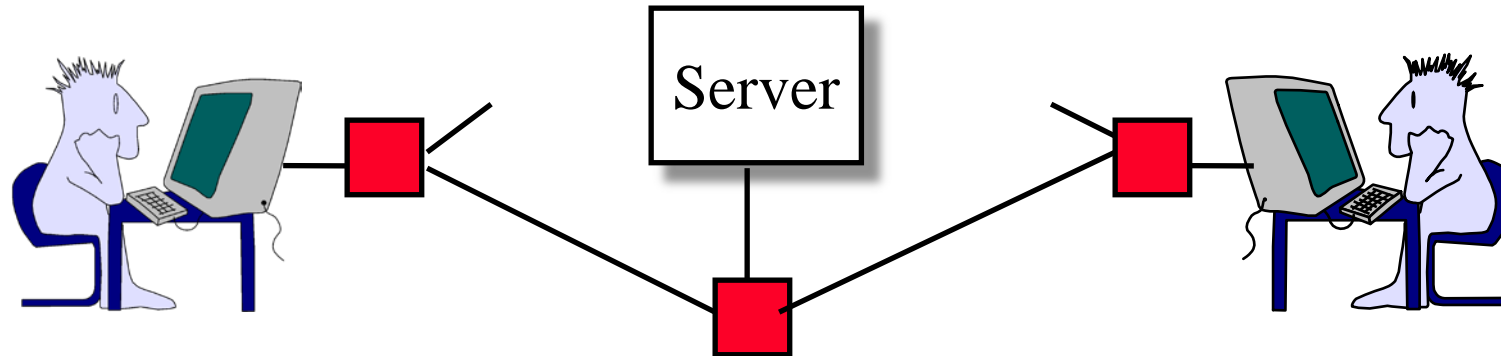

- ❑ **Communication:** Two nodes.
  - Link level electrical issues.



## Student Questions

# Key Concepts



- ❑ **End Systems:** Systems that are sinks or sources of data, e.g., Desktops, Laptops, Servers, Printers, Cell Phones, etc.
- ❑ **Intermediate Systems:** Systems that forward/switch data from one link to another, e.g., routers, switches
- ❑ **Hosts:** End Systems
- ❑ **Gateways:** Routers
- ❑ **Servers:** End Systems that provide service, e.g., print server, storage server, Mail server, etc.
- ❑ **Clients:** End systems that request service
- ❑ **Links:** Connect the systems.  
Characterized by transmission rate, propagation delay

## Student Questions

- ❑ Could an intermediate system be considered a link?  
*Link is usually a medium, e.g., wire or radio, or light.*
- ❑ Could the service of linking two nodes characterize a system as a server?

*Not necessarily. A router is an intermediate system. Even though they are providing the routing service, we don't typically call them servers, particularly since they are invisible.*

---

# What is Internet?

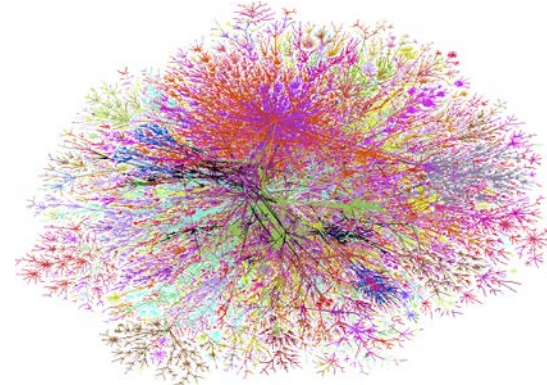
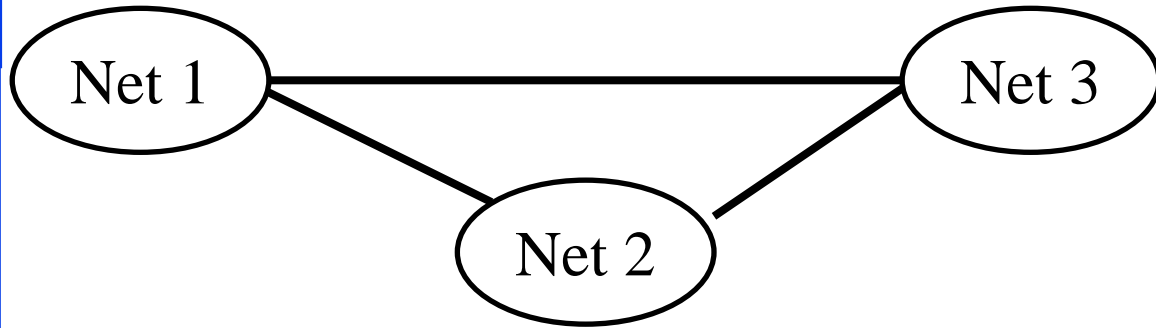

- ❑ Internet = Inter-Network = Network connecting networks
- ❑ Approximately 1.05B hosts on Internet in 2016.
- ❑ ISP: **Internet Service Provider**.
  - Provide access to Internet.
  - Telecommunications (Telephone) Companies, AT&T, Verizon, Comcast, ...
  - Coffee Shops (Wi-Fi)

## Student Questions

Ref: <http://www.statista.com/statistics/264473/number-of-internet-hosts-in-the-domain-name-system/>

Washington University in St. Louis

<http://www.cse.wustl.edu/~jain/cse473-22/>

©2022 Raj Jain

# Types of Networks

## □ Point to point vs. Broadcast

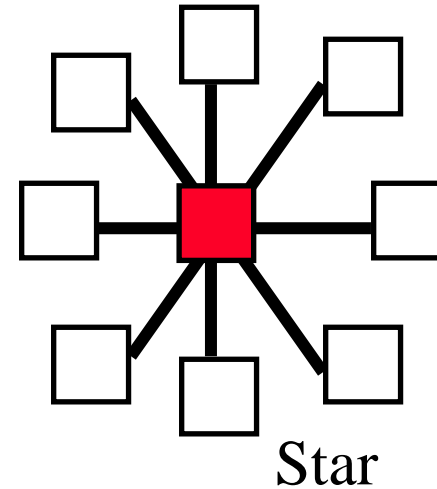
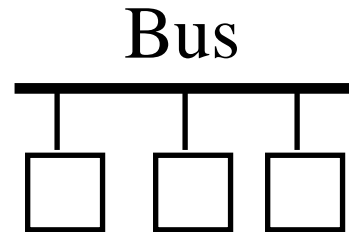
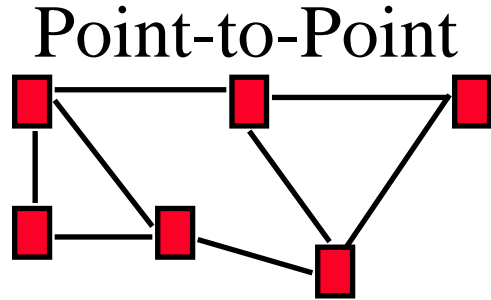

## □ Circuit switched vs. packet switched

□ **Circuit:** A path (circuit) is setup before transmission.  
All bits follow the same path, e.g., Phone

□ **Packet:** Packets of bits are forwarded individually

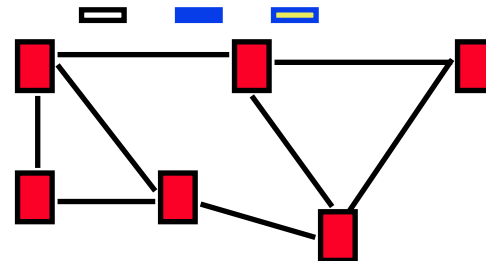
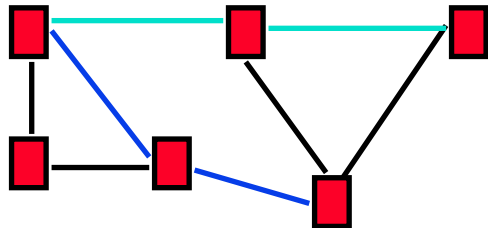

## Student Questions

- When you said in the old days ethernet was a bus...You meant when it was over coax?  
*No. It was still UTP but all nodes connected to one wire. Ethernet over Coax was designed but didn't last long.*
- What is the difference between red and white squares?  
*None. Author's choice.*
- Is the star considered point to point or broadcast?  
*It could either one. More details in Chapter 4.*
- Is broadcast synonymous with bus?  
*No. Bus is always broadcast. Broadcast can be done without a bus.*



# Multiplexing

- ❑ How multiple users can share a link?
- ❑ **Time Division Multiplexing (TDM)**

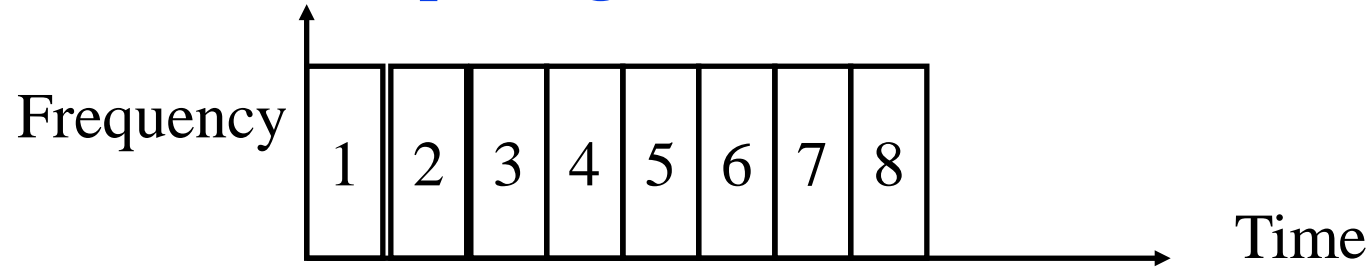

- ❑ **Frequency Division Multiplexing (FDM)**

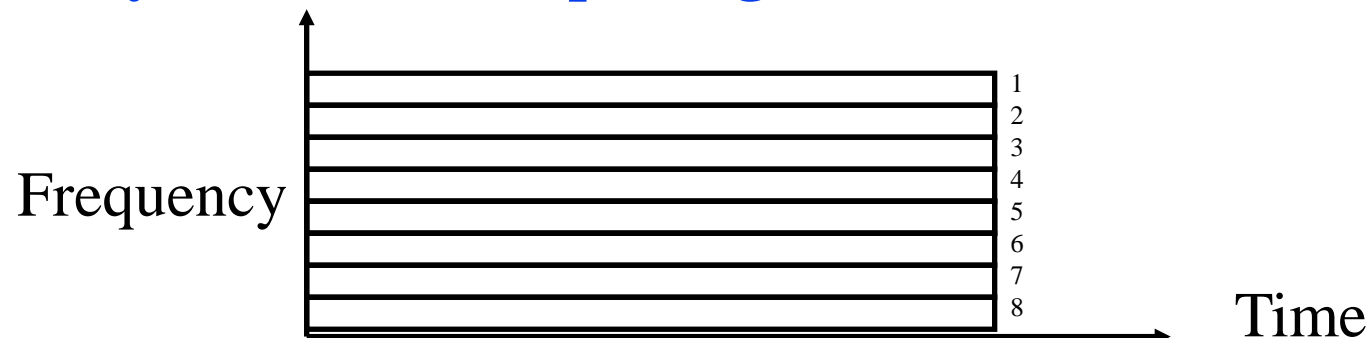

- ❑ Other multiplexing methods will be covered as needed.

## Student Questions

- ❑ Does FDM allow truly simultaneous usage by multiple users?  
*Yes. Everyone is on a different frequency.*
- ❑ Will anything be fair game for exams and such? For example you mention that ethernet is TDM, would we be tested on that?

*Yes.*

# Types of Networks (Cont)

- ❑ **Local Area Networks (LAN):** 0-2 km, Single Ownership
- Metropolitan Area Networks (MAN)** 2-50 km,
- Wide Area Networks (WAN)** 50+ km
  - Originally LAN/MAN/WAN technologies were different
  - Now they are all same
- ❑ **Telecom Networks:**
  - **Access:** Between subscriber and the service provider
  - **Metro:** Covering a city
  - **Core:** Between cities

## Student Questions



# Structure of the Internet

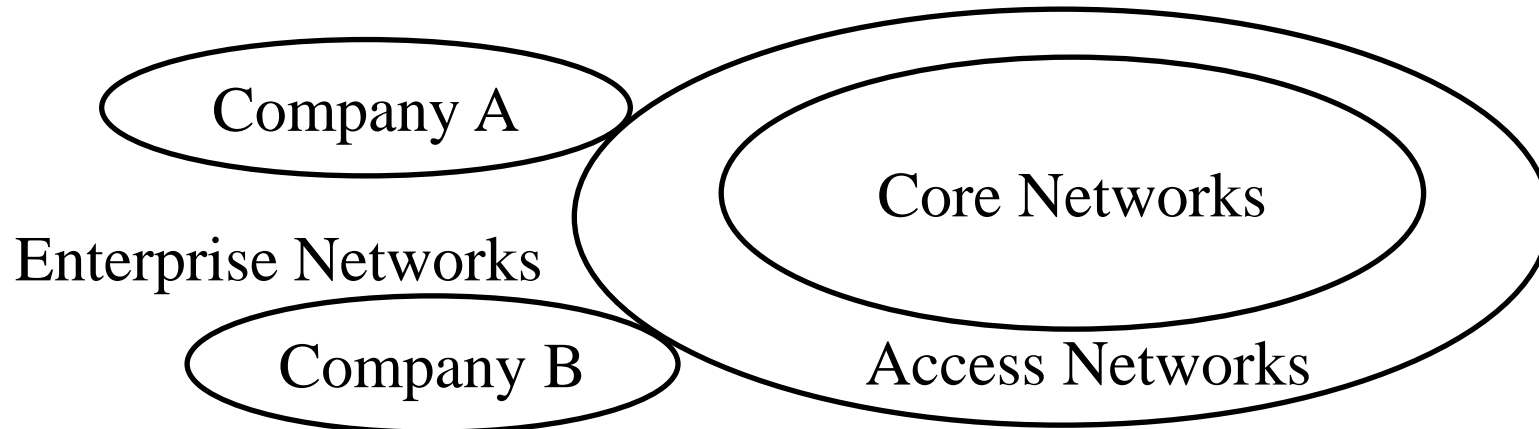

- ❑ Enterprise/Home Networks: **Stub** Networks.  
Privately owned  $\Rightarrow$  Not owned by ISP  
e.g., WUSTL network: Ethernet and WiFi
- ❑ **Access** Network: Enterprise/Users to ISP (in the city)  
WiFi, 3G/4G, DSL
- ❑ **Core** Network: ISP's network (between city): Optical Fiber

## Student Questions

- ❑ Why this diagram depicts core networks as a subset of access networks?  
*This is not a Venn diagram.*
- ❑ Why the access networks circle is bigger than core networks.

*Access is on the edges of the core. Access connects to customers and is every where.*

*The airplanes owned by FedEx/ Amazon/UPS are their core transports.*

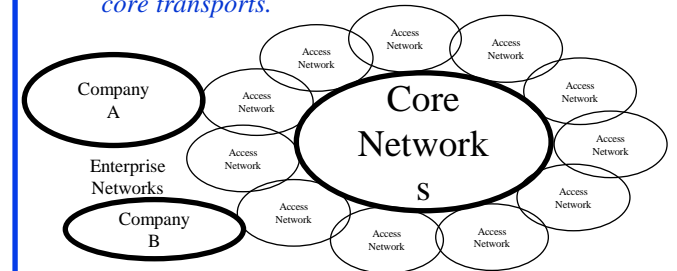

**More questions at the end.**

# Types of ISPs

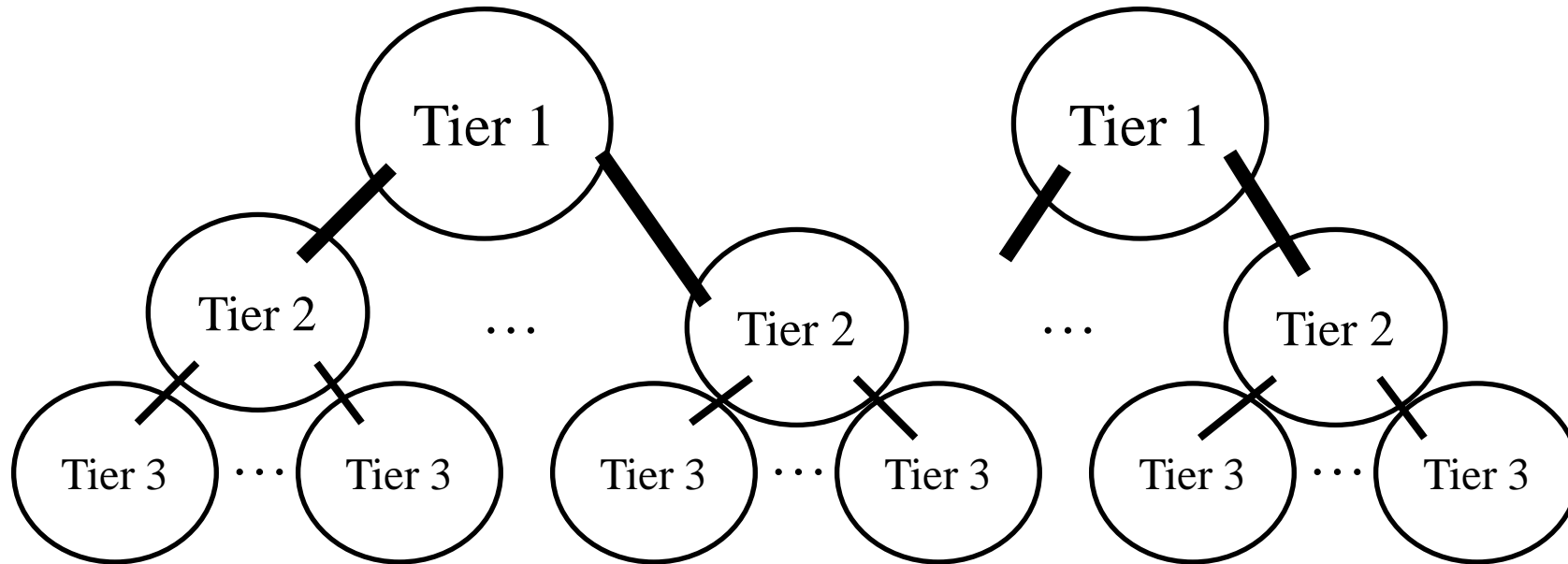

- ❑ **Tier 1:** Global or National, e.g., AT&T, Verizon, ...
- ❑ Tier 2: Regional
- ❑ Tier 3: Local

## Student Questions

- ❑ At what level/tier are tier 1 ISPs usually connected to each other?  
*There are no higher Tier ISPs. A Tier 1 network might be connected to another Tier 1 network through a third Tier 1 network.*
- ❑ Would you elaborate on practical differences between coaxial vs twisted pair (for example relative transmission rates), and on practical differences between wireless vs microwave?
  - ❑ Is all wireless microwave?  
*No. Please wait till Module 7.*
  - ❑ Is the main upside to unguided transmission media the ability to have the end system to be more mobile?  
*Some times wireless is used between towers to reduce cabling cost.*
- ❑ When you refer to just "fiber", are you referencing optic fiber?  
*Yes*

# Transmission Media

## □ Guided:

- Twisted Pair
- Coaxial cable
- Optical fiber

## □ Unguided:

- Microwave
- Satellite
- Wireless

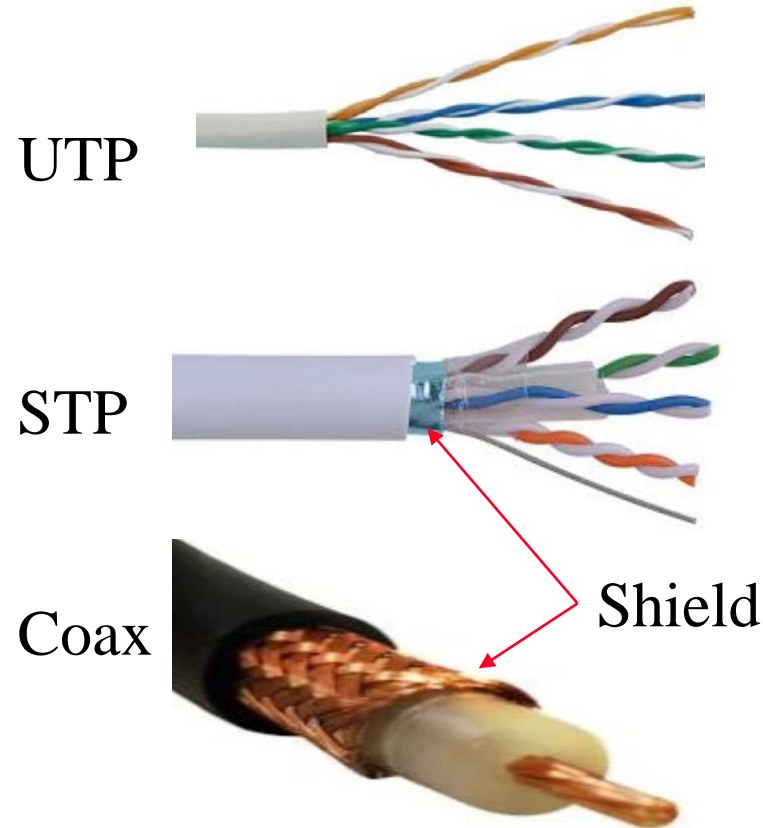

## Student Questions

- It was mentioned in lecture that a Coaxial cable is an example of an STP (Shielded Twisted Pair). Googling the difference seems to indicate that "Twisted Pair Cables" are distinct from "Coaxial Cables". Can you clarify the relationship between Twisted Pair vs Coaxial?  
*Coaxial cable is shielded but not twisted because it has only one wire. STP has many pairs and each pair is twisted. A metallic shield protects all pairs.*
- Are satellites becoming a more viable option because there are more in space which can communicate directly with each other instead of having to switch between space and earth frequently?  
*Cost-effectiveness of satellites has been changing. They are expected to become cost-effective soon.*

# Twisted Pair (TP)

- Separately insulated
- Twisted together
- Often "bundled" into cables
- Usually installed in building during construction



(a) Twisted pair

- Twists decrease the cross-talk
- Neighboring pairs have different twist length
- Most of telephone and network wiring in homes and offices is TP.

## Student Questions

# Shielded and Unshielded TP

## ❑ Shielded Twisted Pair (STP)

- Metal braid or sheathing that reduces i
- More expensive
- Harder to handle (thick, heavy)
- Used in token rings

## ❑ Unshielded Twisted Pair (UTP)

- Ordinary telephone wire
- Cheap, Flexible
  - ⇒ Easiest to install
- No shielding
  - ⇒ Suffers from external interference
- Used in Telephone and Ethernet

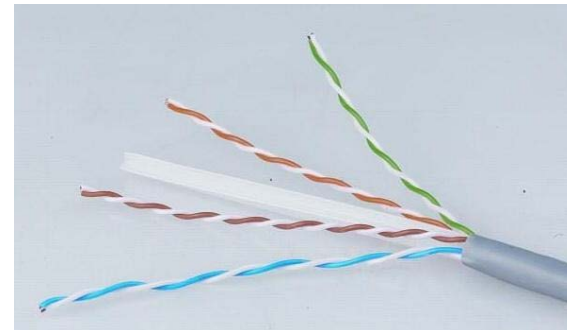

## Student Questions

- ❑ How specifically are infrared light used to input in optical cables?  
*Lasers are used to inject light in to a hair-thin optical fiber.*

# UTP Categories

## □ Cat 3

- Up to 16MHz
- Voice grade found in most offices
- Twist length of 7.5 cm to 10 cm

## □ Cat 4

- Up to 20 MHz. Not used much in practice.

## □ Cat 5

- Up to 100MHz
- Used in 10 Mbps and 100 Mbps Ethernet
- Twist length 0.6 cm to 0.85 cm

- Cat 5E (Enhanced to 100 MHz),  
Cat 6 (250 MHz), Cat 6A (500 MHz),  
Cat 7 (700 MHz), CAT 7A (1000 MHz)  
Cat8 (2000 MHz), ...

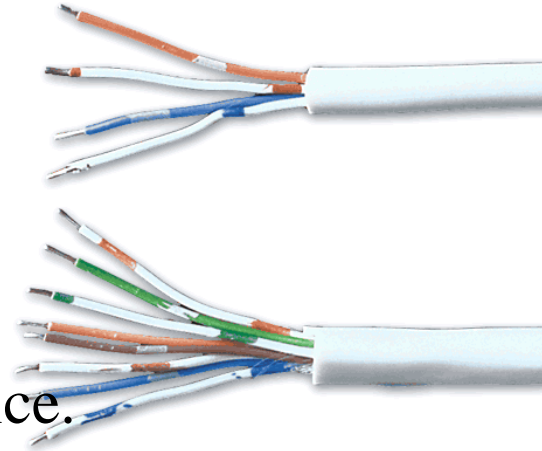

## Student Questions

# Optical Fiber

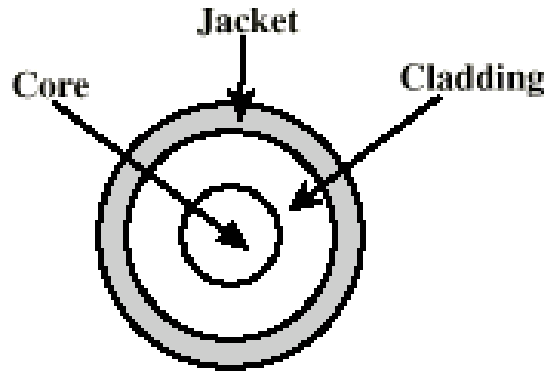

- Glass or plastic core
- Laser or light emitting diode
- Specially designed jacket
- Small size and weight

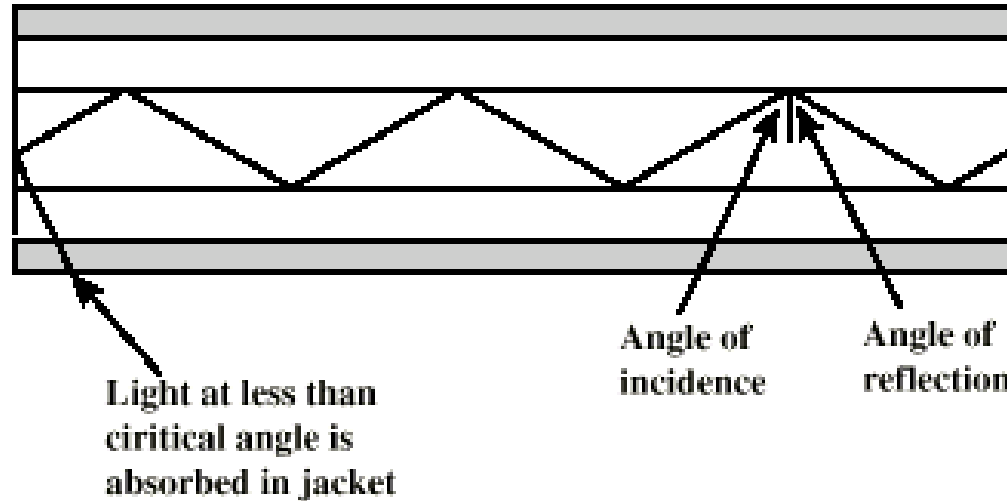

- A cylindrical mirror is formed by the cladding
- The light wave propagate by continuous reflection in the fiber
- Not affected by external interference  $\Rightarrow$  low bit error rate
- Fiber is used in all long-haul or high-speed communication
- Infrared light is used in communication

## Student Questions

- Is infrared considered a to be a subset of microwaves?  
*These are different frequencies. See Slide 18.*
- How much do we need to know about the spectrum? (like what range is radio)  
*Yes.*
- Is it possible to use ultraviolet light or visible light for optical communication as both of them have a shorter wavelength and thus seem to have a higher possible transmission rate?  
*Yes. Properties of the signal are different and so cost and applications are different.*

# Optical Communication...History

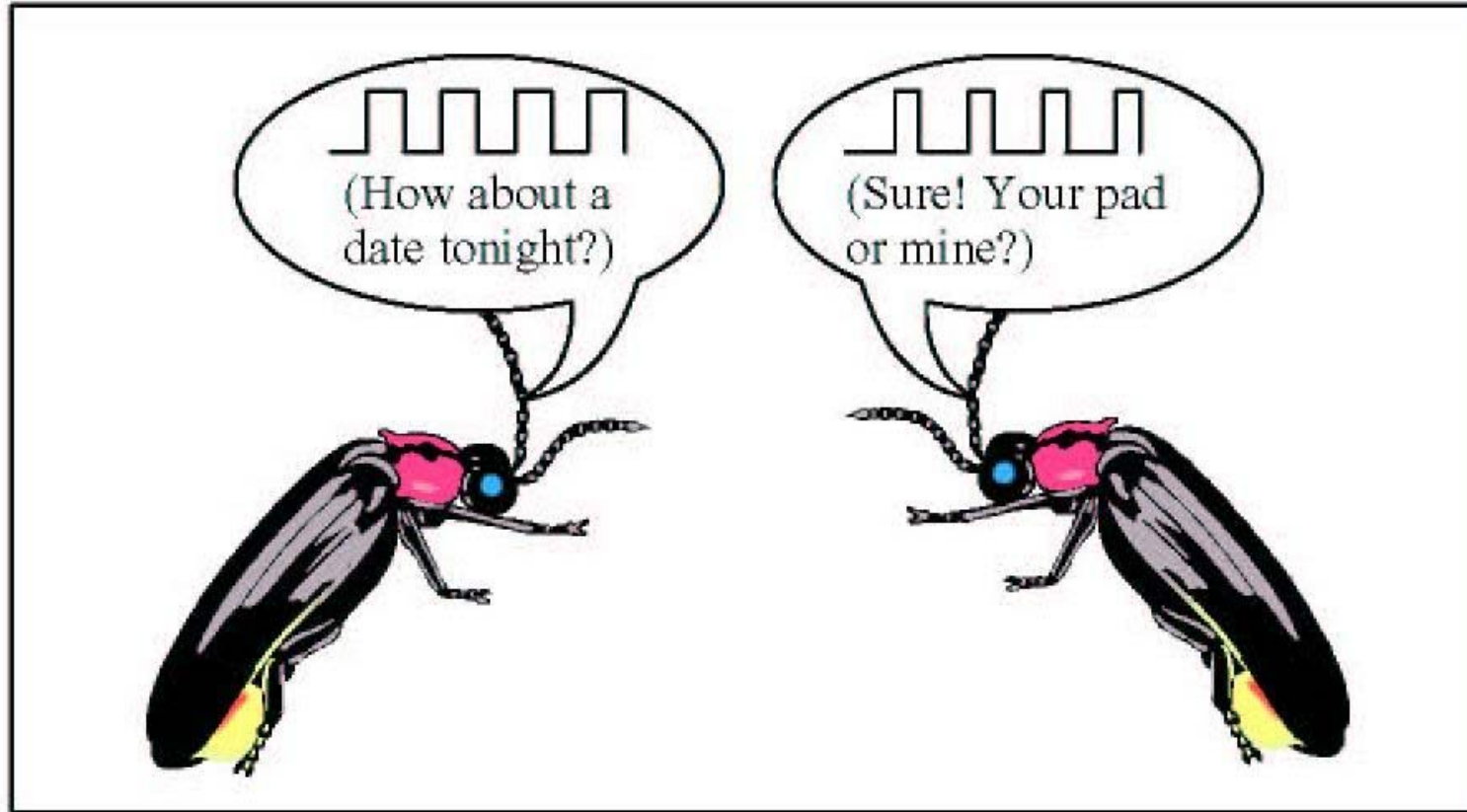

Fireflies use pulse-width modulation.

## Student Questions



# Electromagnetic Spectrum

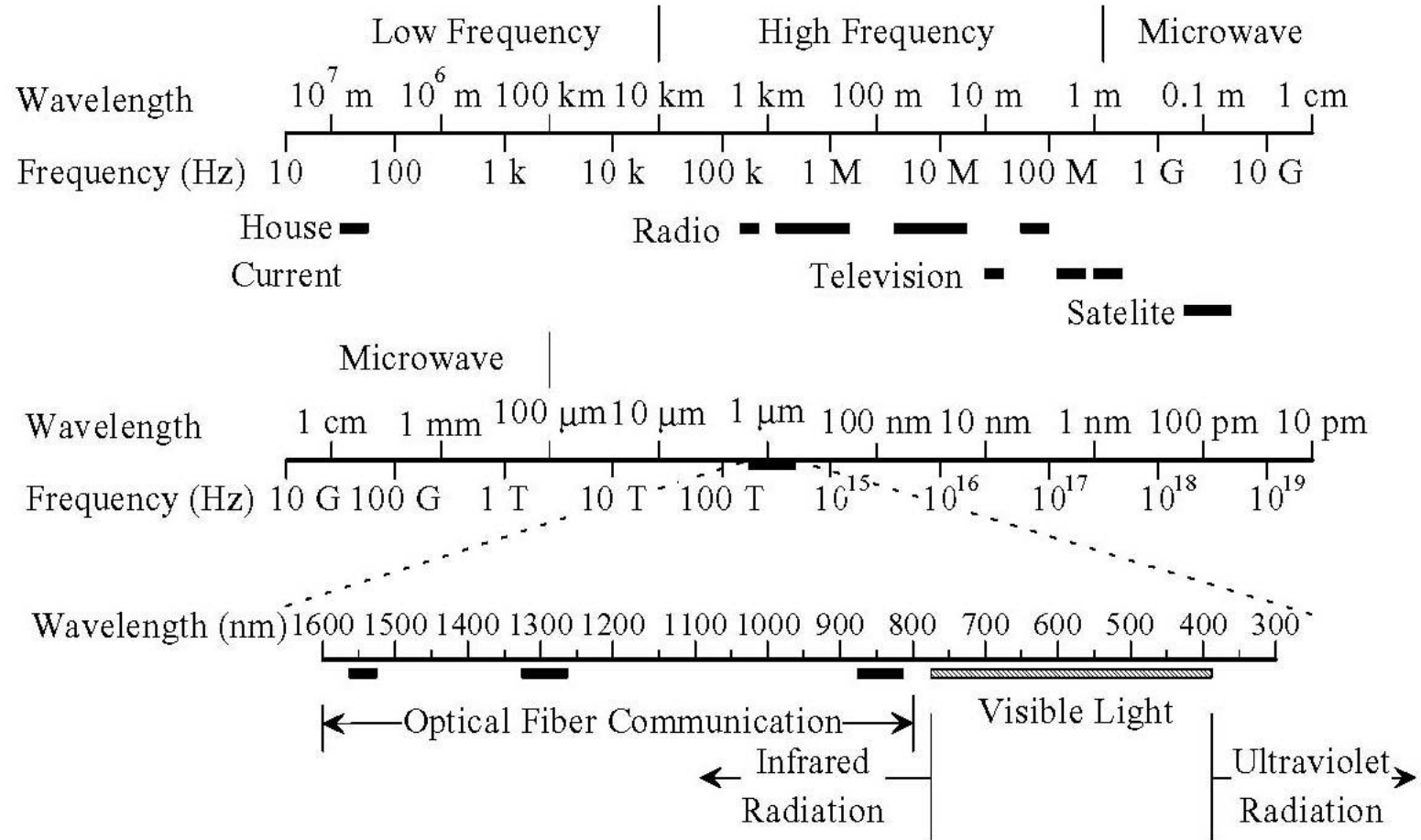

- Infrared light is used for optical communication

## Student Questions

# Homework 1A: Networking Media

- [6 points] Which networking media will you use for the following applications and why?
  1. Very large file transfer at home
  2. High-speed multiple channel video transmission at office
  3. News reading while traveling in a car

Note: Do not write the name of the protocol.  
Write the name of the media and justify.

## Student Questions

- Do we need to do this homework or this is just for some previous semester.  
*While video is from previous live class. The slides have been updated for this semester. So, yes, you need to do the homework and submit it on the Monday following the class discussion.*
-

# Network Edge: Enterprise Networks

1. Ethernet
2. Wi-Fi

## Student Questions

# Ethernet



- ❑ Uses UTP (Unshielded Twisted Pair)
- ❑ 10 Mbps, 100 Mbps, 1 Gbps, 10 Gbps
- ❑ Originally bus, now point-to-point (Star) topology

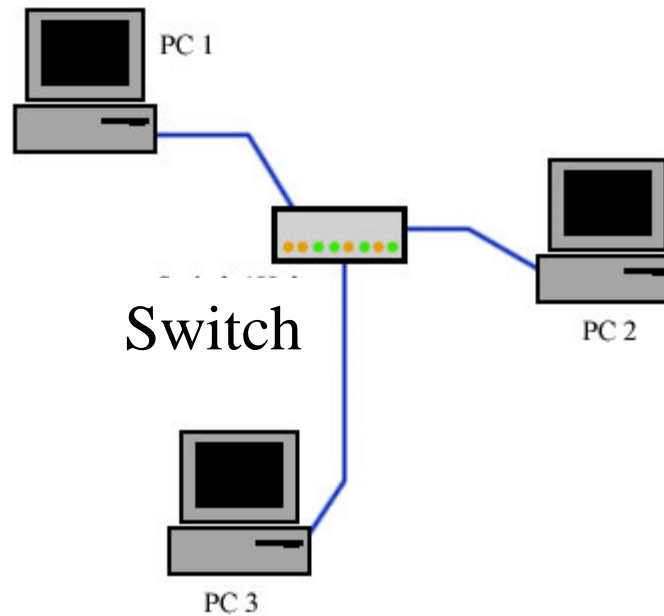
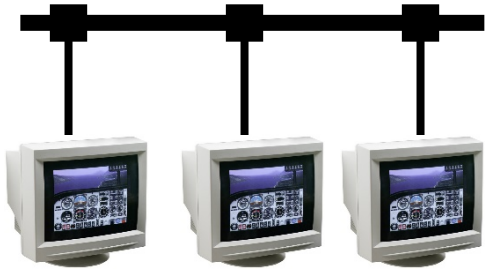

## Student Questions

- ❑ Was it the bus or star topology that was more robust against single connection faults?  
*Bus is susceptible to single cable faults.*

# Wi-Fi

- ❑ IEEE 802.11  
(Institution of Electrical and Electronic Engineers)
- ❑ Uses 2.4 GHz and 5.8 GHz



## Student Questions

# Access Networks

1. DSL (Digital Subscriber Line)
2. Cable
3. Fiber-To-The-Home
4. Wi-Fi
5. LTE (Long Term Evolution)

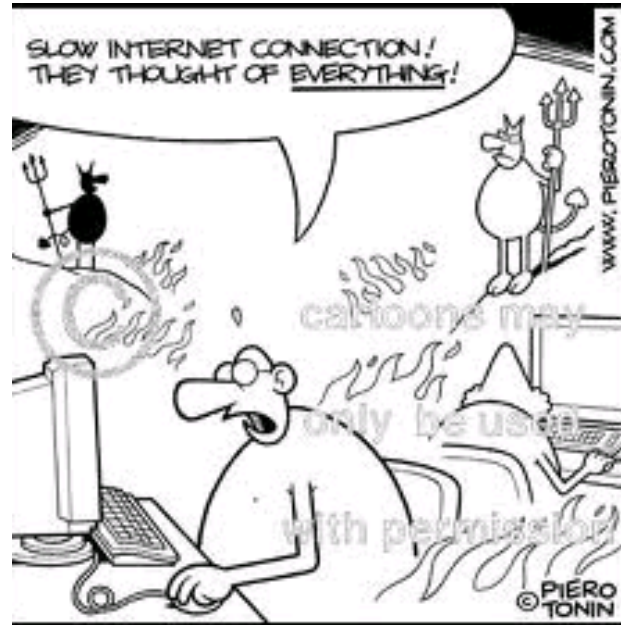

## Student Questions

- How is LTE different from 4G?  
*This is discussed in Module 7. LTE is 3.9G or pre-4G.*
- What is LTE/ what does Long Term Evolution mean?  
*Please wait till Module 7.*
- Does Fiber to the Home mean Optical fiber?  
Yes.

# DSL

- ❑ **Digital Subscriber Line (DSL)**
- ❑ Can transmit very high data rates on phone wire using special equipment at the phone company allowing higher frequency signals

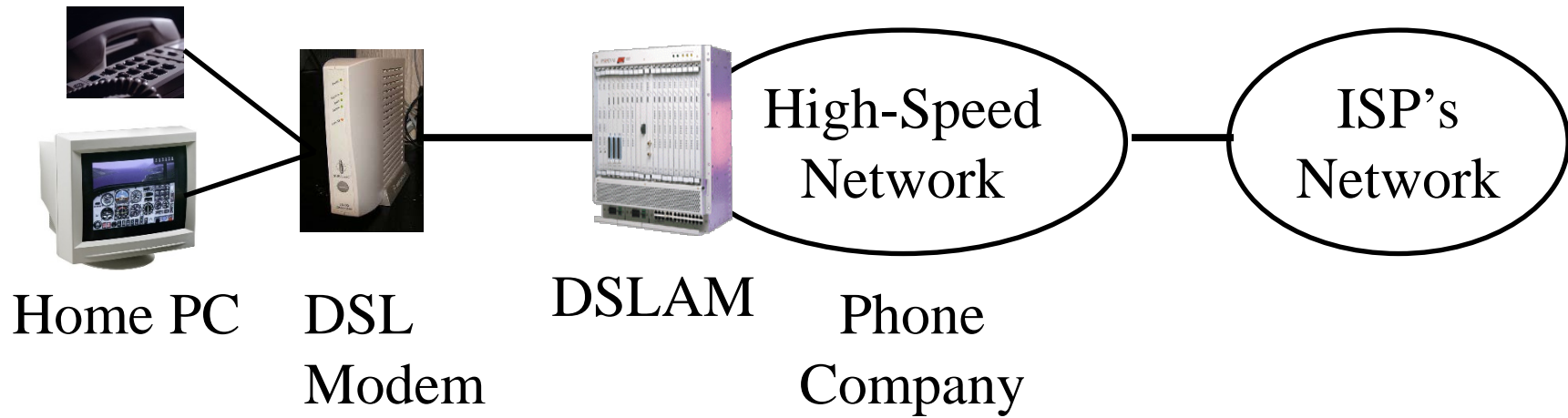

- ❑ DSL Access Multiplexer (**DSLAM**)
- ❑ 100 kbps - 100 Mbps

## Student Questions

- ❑ The video had 24 slides (whereas this form only lists 23)
- Our mistake.*
- ❑ Part 2 link reported "The requested URL /~jain/cse473-21/ftp/i\_1cni/i\_1cni2.html was not found on this server."
- Part 2 was not required till now. It was under preparation when you clicked. It is there now.*
- ❑ You mentioned there is a homework 1 on canvas. I am have some problem finding it.
- Homework 1A is on these slides. Since it is due only after the class discussion, it was not published on Canvas. It is there now.*
- ❑ Where do we turn in our in class assignment?
- Unless indicated otherwise, all homeworks should be submitted on Canvas.*



# Cable

- ❑ Cable companies have a very-high speed medium (for video transmission)
- ❑ Phone wire = 4kHz for voice  
Video Cable = 500 MHz for video  
One TV Channel = 6 MHz
- ❑ 100 Mbps down/10 Mbps up
- ❑ Fiber in the main line + Coax in tributaries  
⇒ Hybrid Fiber Coax (HFC)



Cable  
Modem

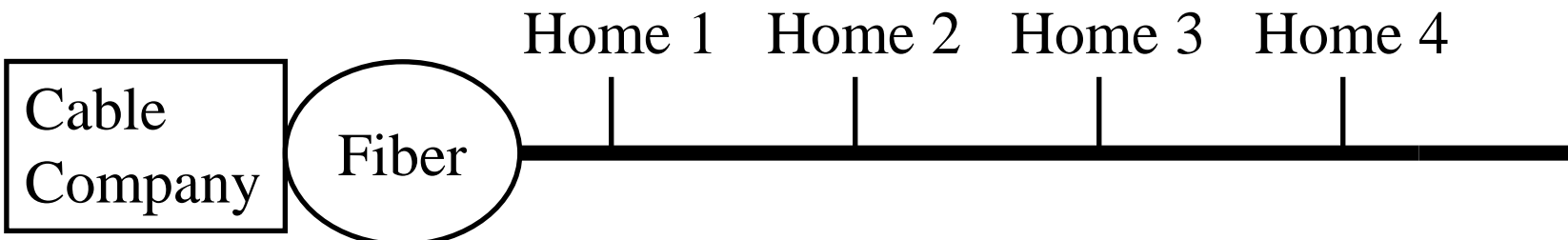

## Student Questions

- ❑ Why is the upload speed always slower than the download speed?  
*Not always. On point-to-point fiber, upload = download.*
- ❑ Is it the only difference in structure between DSL and cable that DSL uses UTP while cable uses coaxial wire?  
*No there are many other differences. Not just media but also protocols.*



# Fiber-To-The-Home (FTTH)

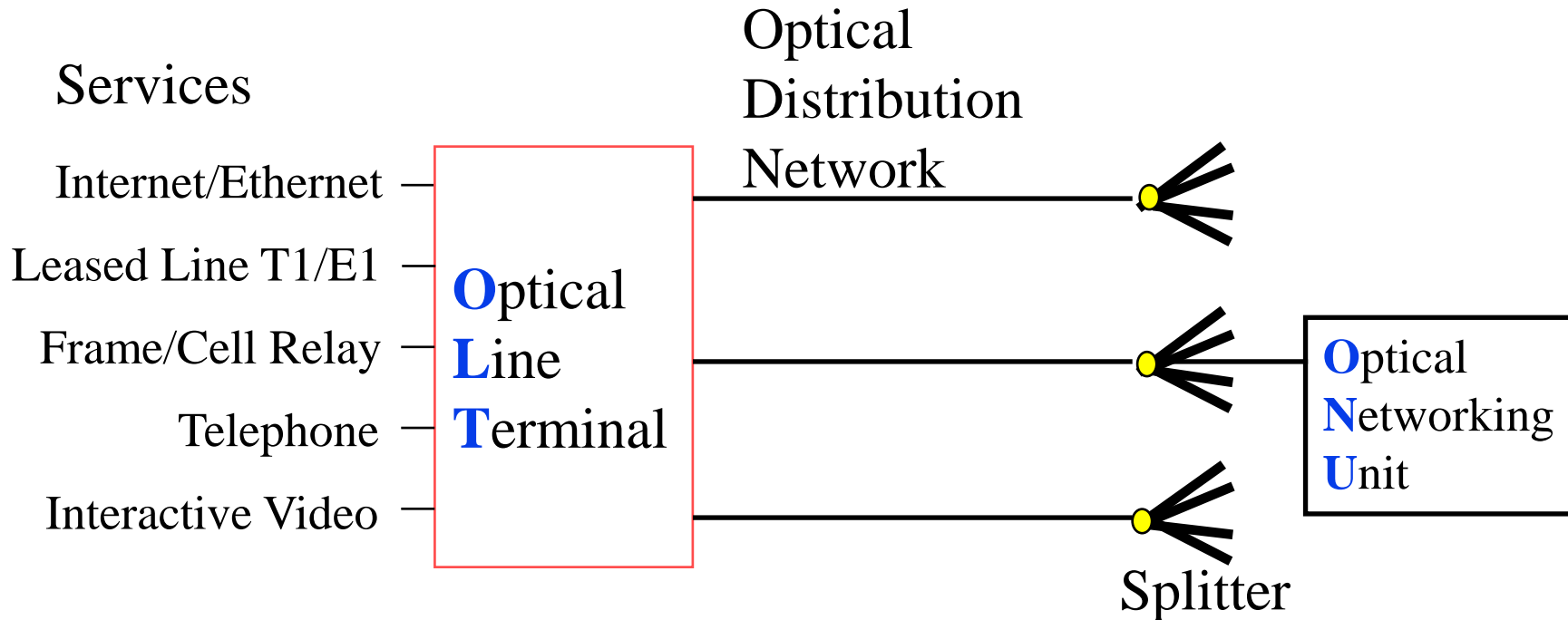

- ❑ 1+ Gbps per home. Multiple services.
- ❑ No electronic components in the distribution system  
⇒ Passive ⇒ Reliable
- ❑ Passive Optical Network (PON)

## Student Questions

- ❑ What is the difference between analog and digitalized DSL?

*Analog signal*



*Digital signal*



- ❑ How frequently is FTTH used in the US compared to cable?

*AT&T Fiber just came to St. Louis.*

- ❑ Is FTTH more reliable than cable?

*Not necessarily.*

- ❑ Do DSL and cable also use a passive splitter as FTTH does? If not, then how do they distribute the packets?

*DSL has switches and routers to distribute to packets. These are not passive. Cable can use switches or hubs. Hubs can be passive but are not generally used.*

# Wireless Access Networks

- ❑ Wi-Fi hot spots
- ❑ Cellular access: 2G/3G/4G (LTE)

## Student Questions

- ❑ Can you explain what LTE is as well as 2G and 3G? Where on the EM Spectrum does LTE fall?  
*1G/2G/3G/4G/5G are all wireless telecom technologies. We will cover them briefly in Chapter 7. LTE is 3.9G or pre-4G. All of these currently use 700 MHz-5GHz spectrum. The spectrum has to be purchased in Government Auctions.*

# Network Performance Measures

- Delay
- Throughput
- Loss Rate

## Student Questions

# Throughput

- ❑ Measured in Bits/Sec
- ❑ Capacity: Nominal Throughput
- ❑ Throughput: Realistic
- ❑ Bottleneck determines the end-to-end throughput



Net end-to-end capacity = 10 Mbps

Actual throughput will be less due to sharing and overhead.

## Student Questions

- ❑ Can you define overhead?  
*Overhead = Throughput lost due to Packet headers and delays caused by routing.*  
*We discuss these in the next few slides.*

# Loss Rate

- ❑ Queuing  $\Rightarrow$  Buffer overflow
- ❑ Bit Error Rate on the link
- ❑ Lost packets are retransmitted by the previous node or the source

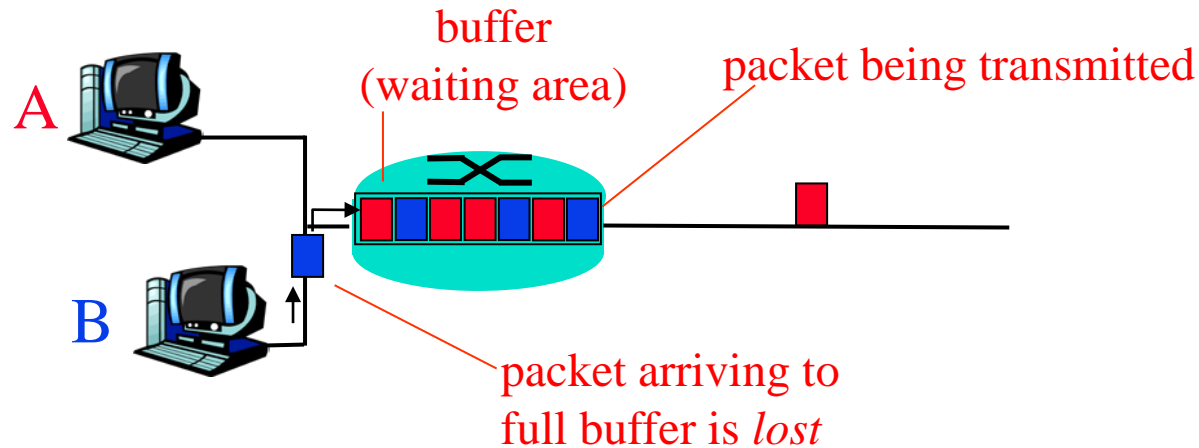

## Student Questions

# Packet Switching Delay

1. **Processing Delay:** Check packets, decide where to send, etc.
2. **Queuing Delay:** Wait behind other packets
3. **Transmission Delay:** First-bit out to last-bit out on the wire  
= **Packet Length/bit rate**
4. **Propagation Delay:** Time for a bit to travel from in to out  
= **Distance/speed of signal**
5. **Speed of Signal:** **300 m/μs** light in vacuum, **200 m/μs** light in fiber, **250 m/μs** electricity in copper cables

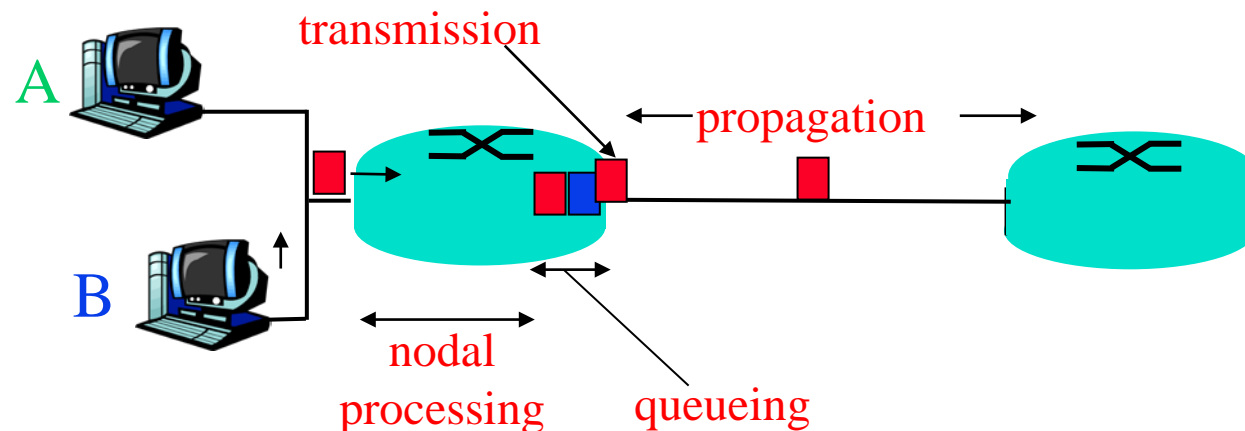

## Student Questions

# Packet Switching Delay: Example

- ❑ 1500 Byte packets on 10 Mbps Ethernet, 1km segment
- ❑ Transmission Delay =  $1500 \times 8 / 10 \times 10^6 = 1200 \mu\text{s} = 1.2\text{ms}$
- ❑ Propagation delay =  $1000 \text{ m} / 2.5 \times 10^8 = 4 \mu\text{s}$

## Student Questions

# Delay Example (CBR Circuits)

- ❑ How long would it take to send a file of 640,000 bits from host A to host B over a circuit-switched network?
  - All links are 1.536 Mbps
  - Each link is shared by 24 users
  - 500 ms to establish end-to-end circuit
- ❑ Per User Rate =  $1536/24 = 64$  kbps
- ❑ Time to transfer =  $640\text{kb}/64\text{kb} = 10$  s
- ❑ Total time =  $.5$  s +  $10$  s =  $10.5$  s

## Student Questions

- ❑ *Are we assuming the link is using TDM? Wouldn't every user get 1.536 Mbps if it were FDM?  
In FDM, the bit/sec depend on Hertz. Hertz is the unit of frequency. So dividing frequency divides the bit rate among users even in FDM.*
-



# Homework 1B: Network Performance

P5 [14 points]: Consider two hosts, A and B, connected by a single link of rate  $R$  bps. Suppose that the two hosts are separated by  $m$  meters, and suppose the propagation speed along the link is  $s$  meters/sec. Host A is to send a packet of size  $L$  bits to Host B.

- A. Express the propagation delay,  $d_{prop}$  in terms of  $m$  and  $s$
- B. Determine the transmission time of the packet  $d_{trans}$  in terms of  $L$  and  $R$ .
- C. Ignoring processing queuing delays, obtain an expression for the end-to-end delay
- D. Suppose Host A begins to transmit the packet at time  $t=0$ . At time  $t=d_{trans}$  where is the last bit of the packet?
- E. Suppose  $d_{prop}$  is greater than  $d_{trans}$ . At time  $t=d_{trans}$ , where is the first bit of the packet?
- F. Suppose  $d_{prop}$  is less than  $d_{trans}$ , at time  $t=d_{trans}$ , where is the first bit of the packet
- ⇒ G. Suppose  $s=3 \times 10^8$  m/s,  $L=290$  bits, and  $R=60$  kbps,. Find the distance  $m$  so that  $d_{prop}$  equals  $d_{trans}$ .

## Student Questions

# Protocol Layers

- Problem: Philosophers in different countries speak different languages. The Telex system works only with English.

I believe there is a God!

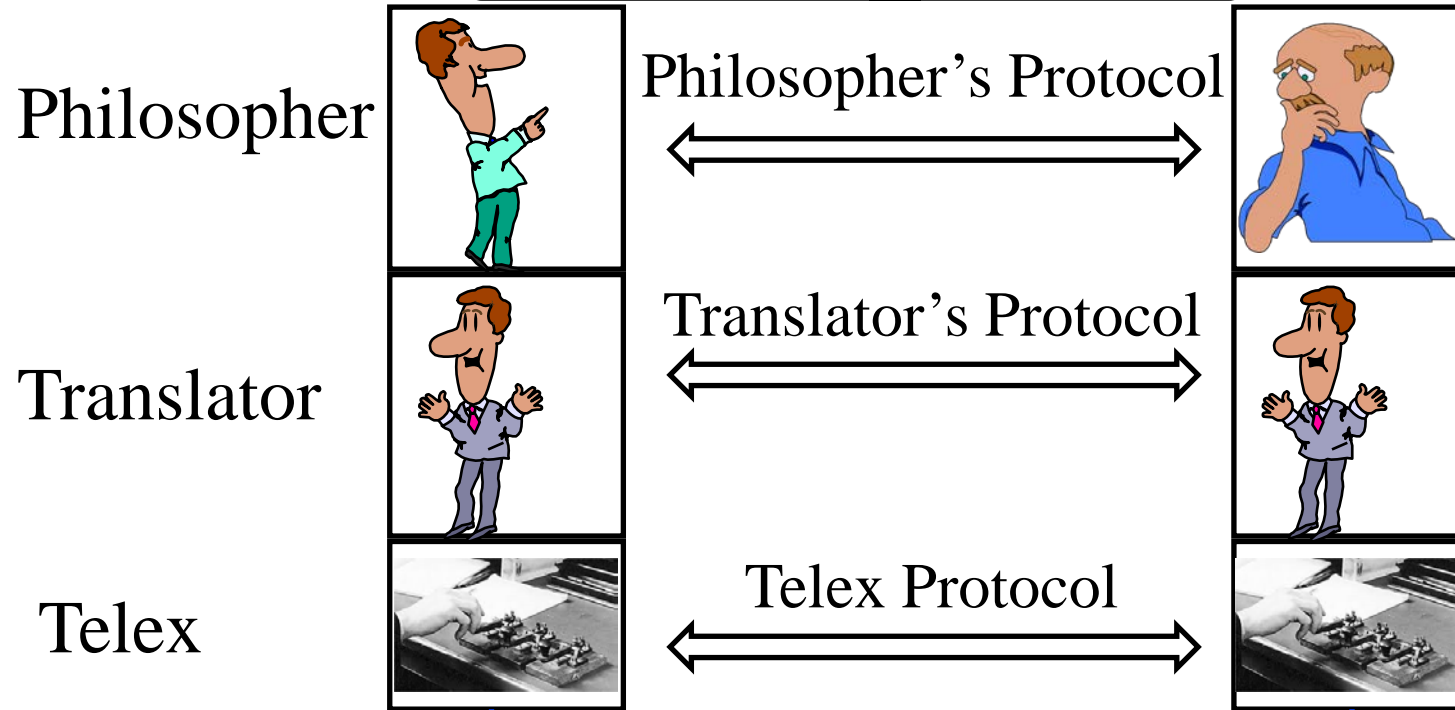

## Student Questions

# What is a Networking Protocol?

- Network protocols define the format of messages, their meanings, sequence, and actions



## Student Questions

# ISO/OSI Reference Model

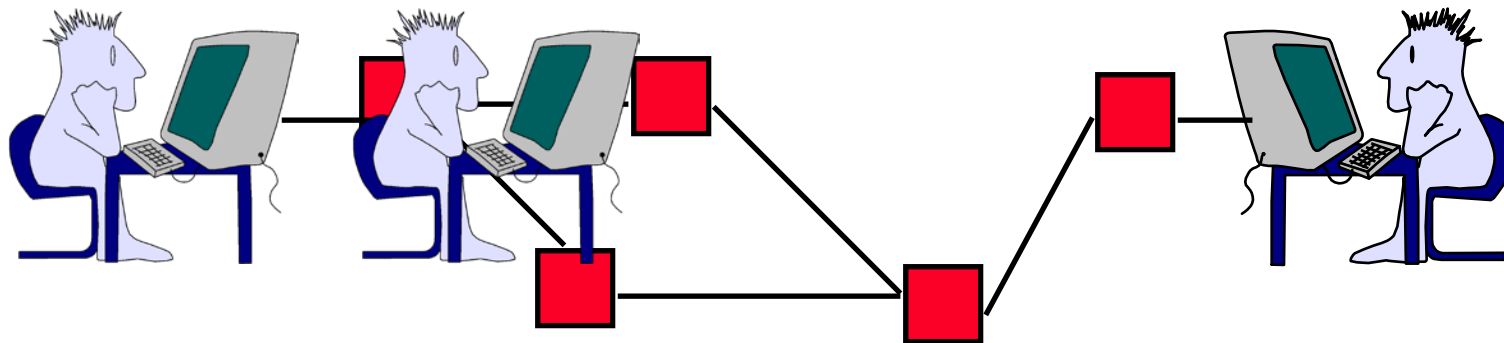
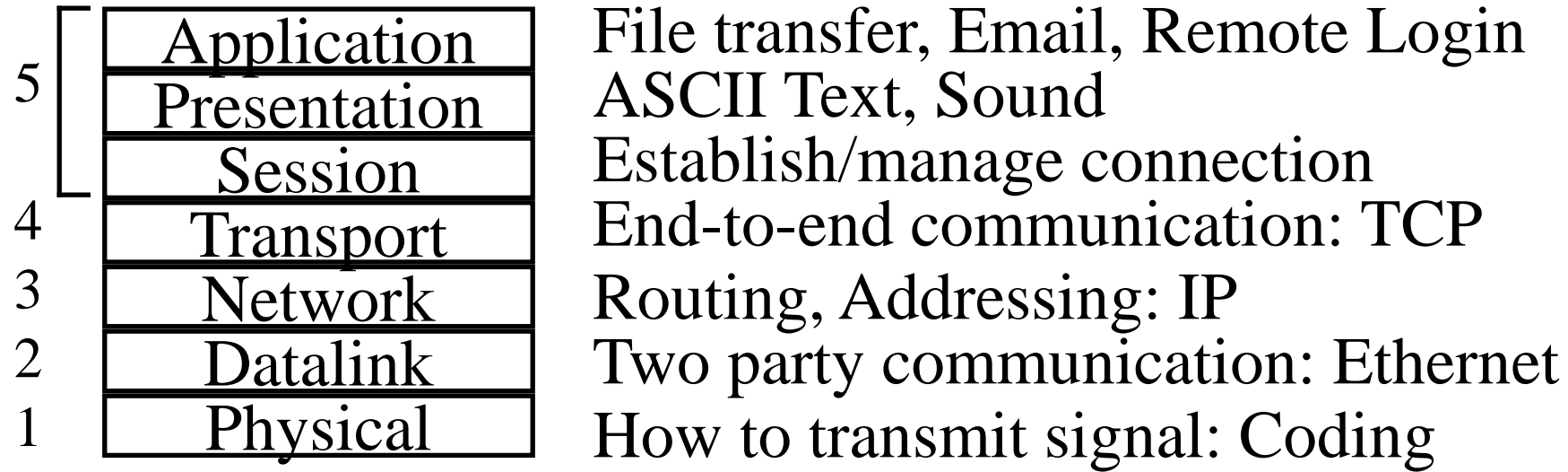

## Student Questions

- Layer 2 and Layer 4 sounds pretty similar to me. Both of them are focusing on communication, could you help me distinguish them?

*One link vs. one path*

*A path has many links on the way. Same functions require different solutions since the latencies are different.*

- Would you clarify what the data link and session levels are responsible for?

*Data link = One link*

*Session = One application*

- Is there an example of a "Session protocol" or is that not a thing at all?

*Mail, HTTP are examples of applications. In TCP, application, presentation, and session layers are combined as one.*

# Service and Protocol Data Units

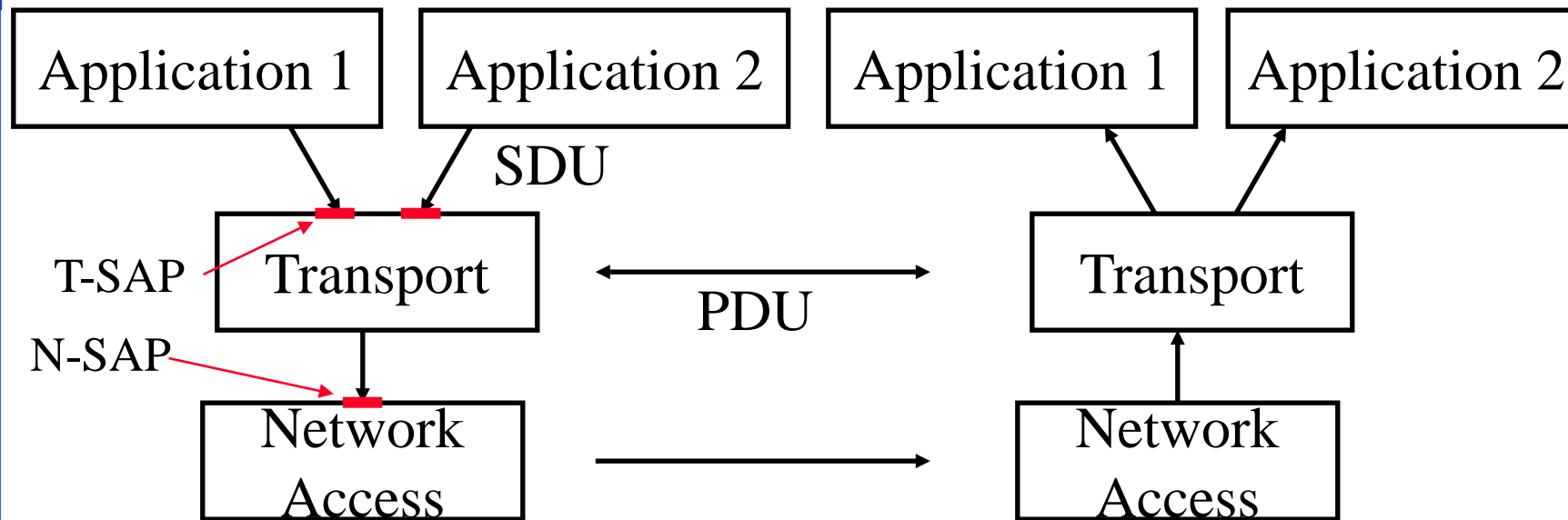

- ❑ **S**ervice **A**ccess **P**oints (SAPs)
- ❑ **S**ervice **D**ata **U**nits (SDUs)
- ❑ **P**rotocol **D**ata **U**nits (PDUs)

## Student Questions

- ❑ What are Service Access Points (SAPs)?  
*See updated figure on the left.*  
*Ports are examples of T-SAPs (Transport SAPs)*

# Service Data Unit (SDU)

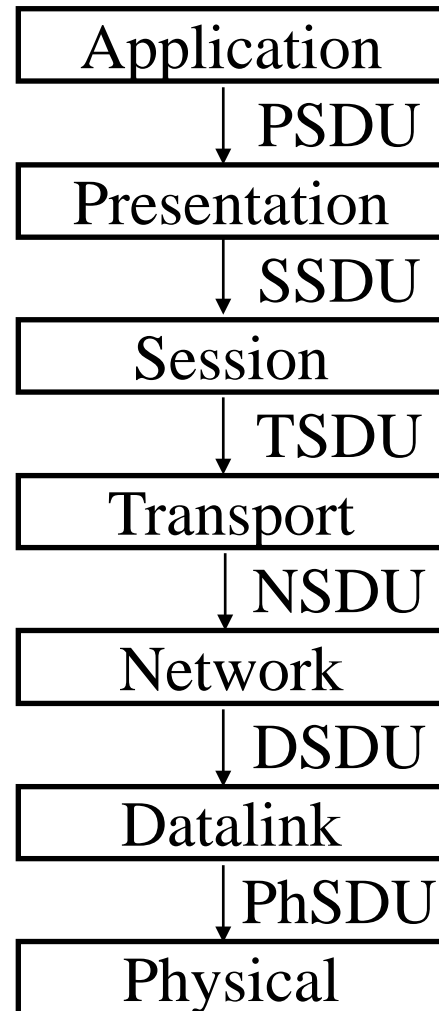

## Student Questions

- Can a layer communicate only with layers directly above and below it or can it skip layers?

*In a strictly layered architecture, the communication is between successive layers only. Although not common, cross-layer communication has been studied and applied for some special situations.*

- Are the SDU and PDU for each layer different actual bit patterns? Is the incoming SDU translated into a PDU for that protocol layer, which is then translated to the SDU for the next layer and transmitted?

*Yes, SDU and PDUs are different for different layers. PDUs are formed by combining or fragmenting SDUs. Each PDU has a header that is understood by the other side.*

# Protocol Data Unit (PDU)

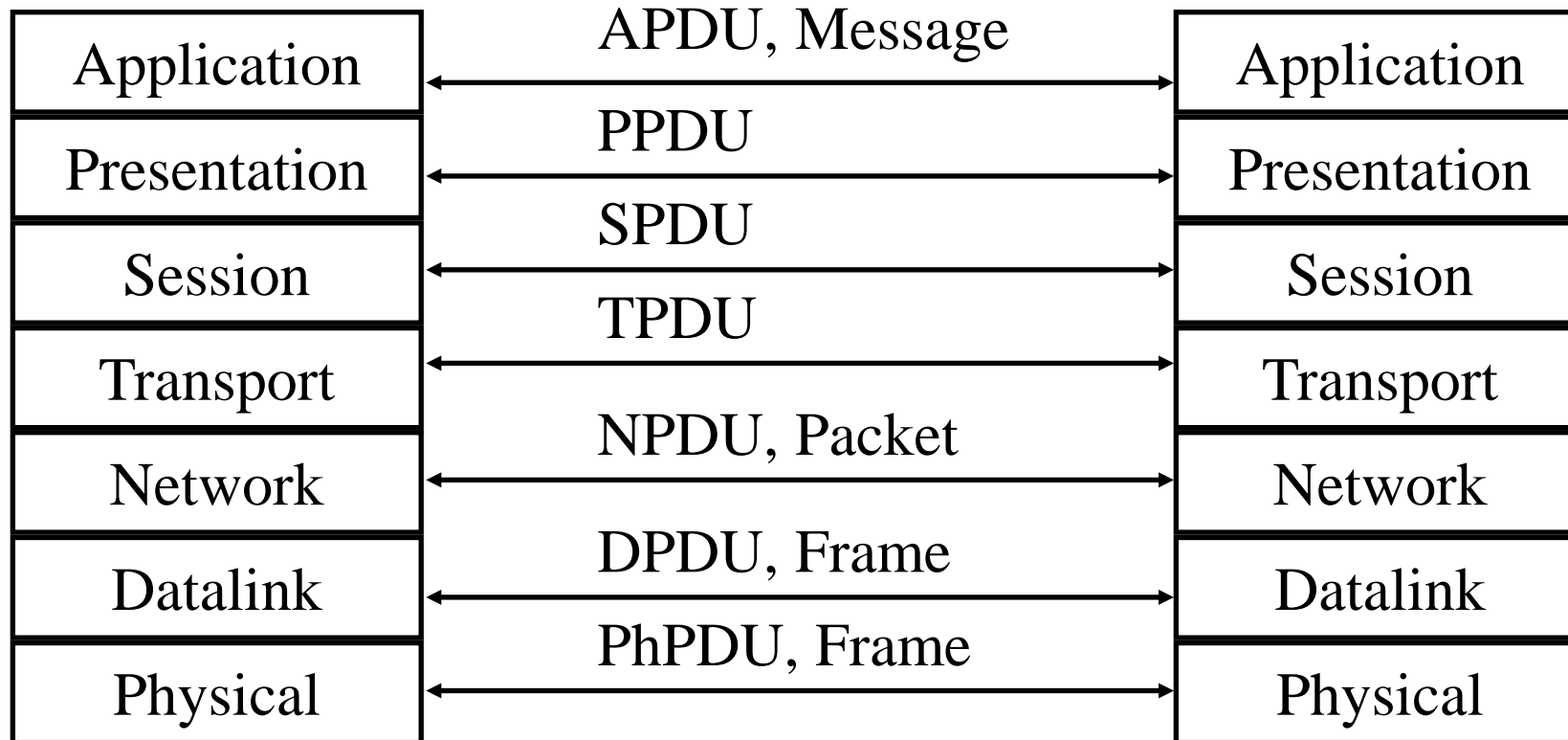

## Student Questions

- What is the difference between SDUs and PDUs?  
*Service data units go down vertically between different layers.*  
*Protocol data units flow horizontally between the entities in the same layer.*

# TCP/IP Reference Model

- ❑ TCP = Transmission Control Protocol
- ❑ IP = Internet Protocol (Routing)

TCP/IP Ref Model

Application
Transport
Internetwork
Host to Network
Physical

TCP/IP Protocols

FTP	Telnet	HTT P
TCP		UDP
IP		
Eth er net	Point- to- Point	Packe t Radio
Coax	Fiber	Wireles S

## Student Questions



# OSI vs TCP/IP

OSI	TCP/IP
Application	Application
Presentation	
Session	
Transport	Transport (host-to-host)
Network	Internet
Data Link	Network Access
Physical	Physical

## Student Questions

- How is the session layer from the OSI model split up between the application and transport layers of the TCP/IP model?

*Some functions of session layer are in TCP and some are not. It doesn't really matter since TCP is now universal along with a few other similar transports.*

- What is the difference between the OSI model and TCP/IP model? I've looked at so many different websites' explanations but still don't understand...

*OSI was done after TCP/IP. However, by the time OSI was partially completed, TCP/IP was universally implemented. So OSI is more methodical but non-existent. TCP/IP is less methodically but everywhere.*

---

# OSI vs TCP Reference Models

- ❑ OSI introduced concept of services, interface, protocols. These were force-fitted to TCP later  
⇒ It is not easy to replace protocols in TCP.
- ❑ In OSI, reference model was done before protocols.  
In TCP, protocols were done before the model
- ❑ OSI: Standardize first, build later  
TCP: Build first, standardize later
- ❑ OSI took too long to standardize.  
TCP/IP was already in wide use by the time.
- ❑ OSI became too complex.
- ❑ TCP/IP is not general. Ad hoc.

## Student Questions

# PDU in TCP/IP Architecture

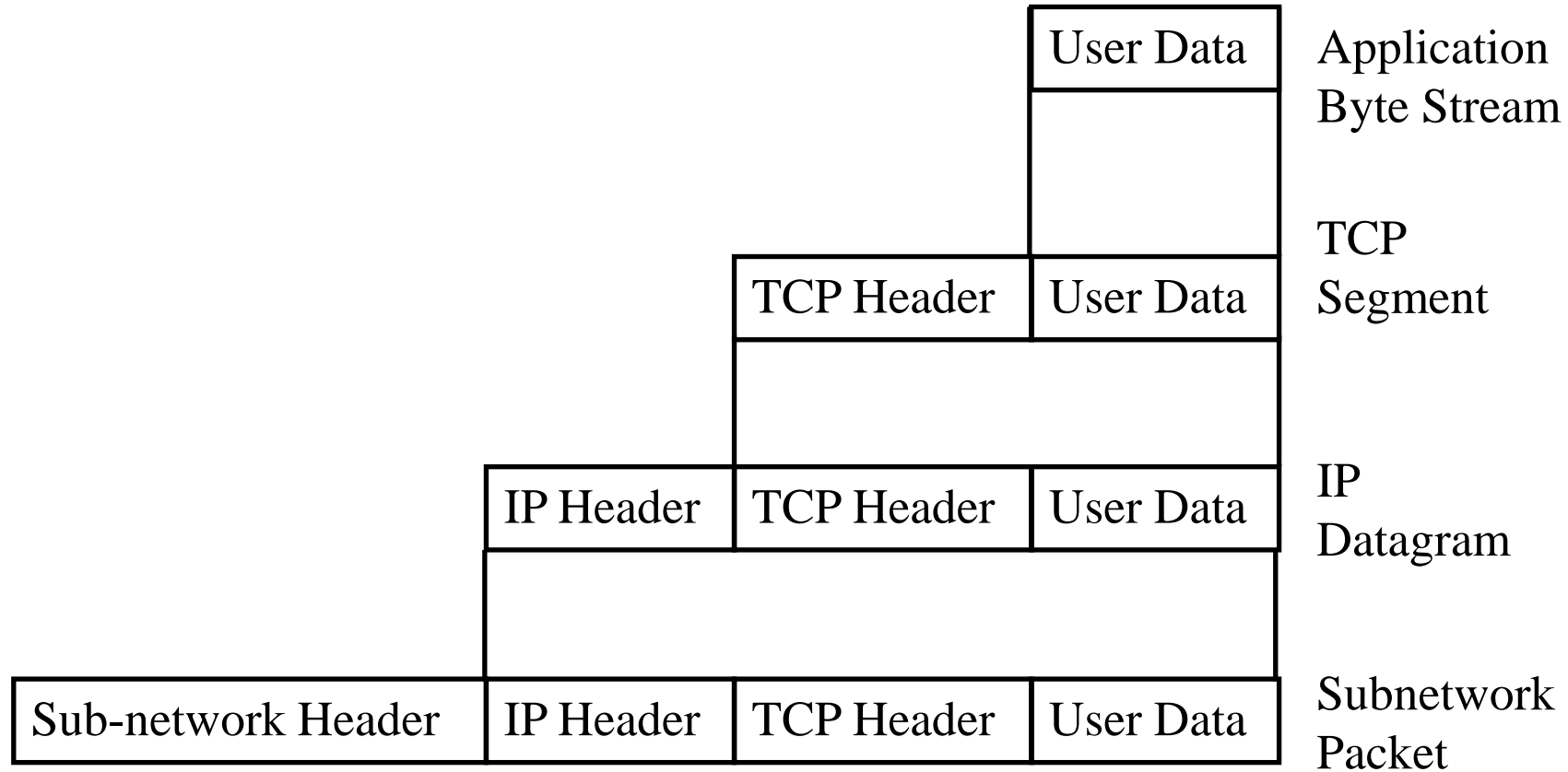

## Student Questions

# TCP/IP Applications

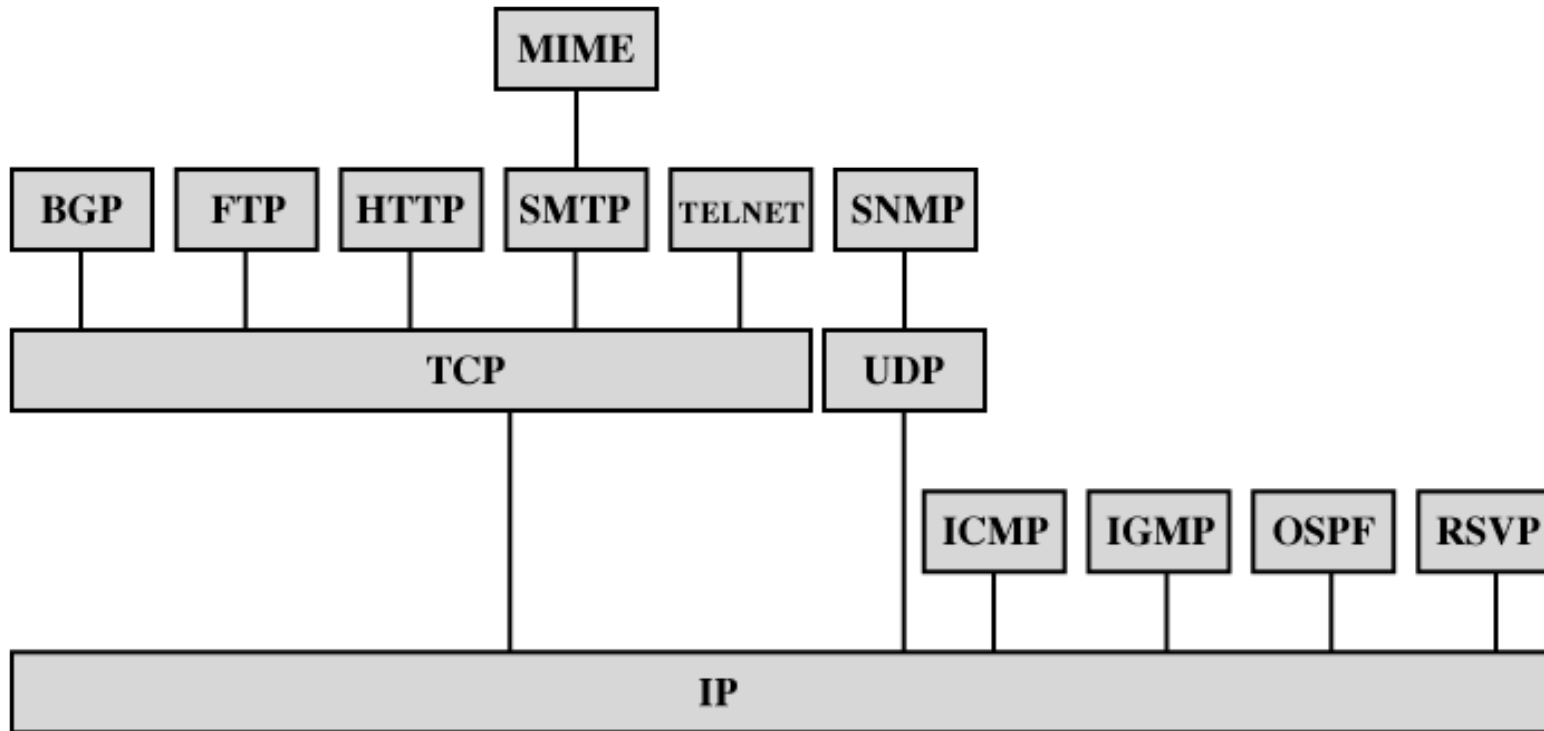

**BGP** = Border Gateway Protocol  
**FTP** = File Transfer Protocol  
**HTTP** = Hypertext Transfer Protocol  
**ICMP** = Internet Control Message Protocol  
**IGMP** = Internet Group Management Protocol  
**IP** = Internet Protocol  
**MIME** = Multi-Purpose Internet Mail Extension

**OSPF** = Open Shortest Path First  
**RSVP** = Resource ReSerVation Protocol  
**SMTP** = Simple Mail Transfer Protocol  
**SNMP** = Simple Network Management Protocol  
**TCP** = Transmission Control Protocol  
**UDP** = User Datagram Protocol

## Student Questions

- Will we be expected to memorize all of these protocols and if they run on TCP/IP/SMTP/etc?  
*Not yet. However, in later modules, we cover some of these protocols. Then you will need to know what runs below and above. This is just a preview and lists too many protocols.*

# Network Security

- ❑ Security Components
- ❑ Types of Malware
- ❑ Types of Attacks
- ❑ Buffer Overflows
- ❑ Distributed DoS Attacks

## Student Questions

# Security Components

- ❑ **Confidentiality**: Need access control, Cryptography, Existence of data
- ❑ **Integrity**: No change, content, source, prevention mechanisms, detection mechanisms
- ❑ **Availability**: Denial of service attacks,
- ❑ Confidentiality, Integrity and Availability (**CIA**)



## Student Questions

- ❑ Does maintaining a security component (e.g., integrity) require the knowledge of the result (e.g., file has been verified with a checksum), or is it enough to know that you have enacted countermeasures and you have not detected any tampering?

*Maintaining a component requires that that component be verified and ensured.*

---

# Types of Malware

- ❑ **Viruses:** Code that *attaches* itself to programs, disks, or memory to propagate itself.
- ❑ **Worms:** Installs copies of itself on other machines on a network, e.g., by finding user names and passwords
- ❑ **Trojan horses:** Pretend to be a utility. Convince users to install on PC.
- ❑ **Spyware:** Collect personal information

This is not a complete list.

## Student Questions

- ❑ Worms and viruses don't sound mutually exclusive based on the definitions given. The difference is only in how they arrive on your system?

*Yes, viruses can fly but worms can only walk.*

# Types of Attacks

- ❑ **Denial of Service (DoS):** Flooding with traffic/requests
- ❑ **Buffer Overflows:** Error in system programs. Allows hacker to insert his code in to a program.
- ❑ **Malware**
- ❑ **Brute Force:** Try all passwords.
- ❑ **Port Scanning:**
  - ⇒ Disable unnecessary services and close ports
- ❑ **Network Mapping**

## Student Questions



# Distributed DoS Attacks

- ❑ **Tribe Flood Network** (TFN) clients are installed on compromised hosts.
- ❑ All clients start a simultaneous DoS attack on a victim on a trigger from the attacker.
- ❑ **Trinoo** attack works similarly. Use UDP packets. Trinoo client report to Trinoo master when the system comes up.
- ❑ **Stacheldraht** uses handlers on compromised hosts to receive encrypted commands from the attacker.

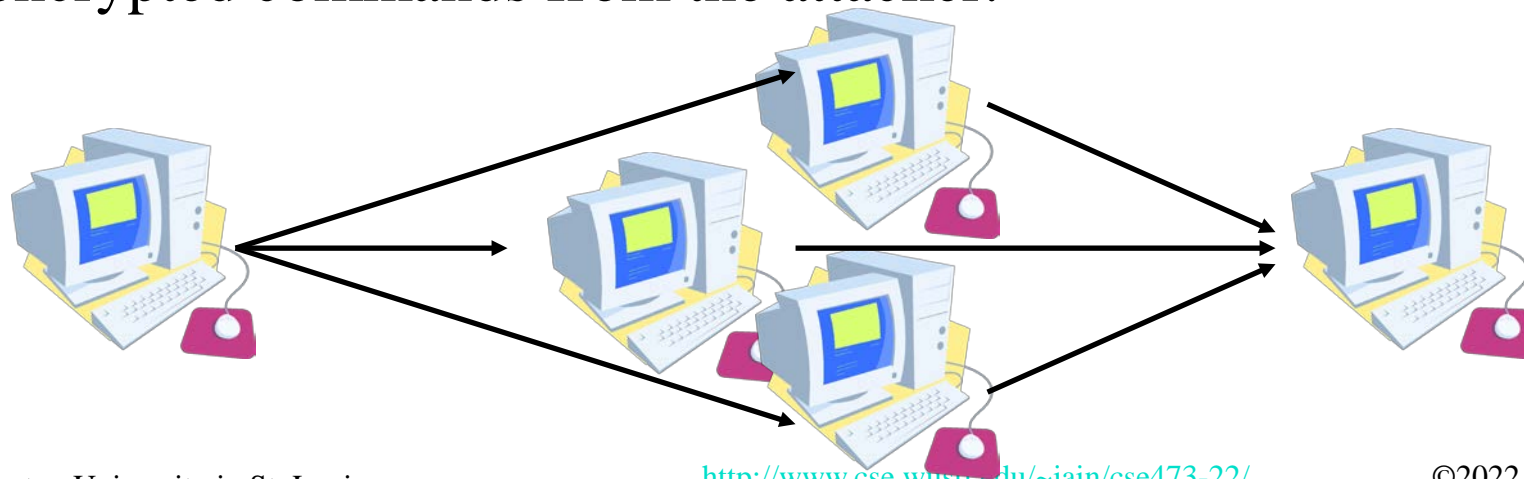

## Student Questions

# History of Internet

- ❑ 1961: Kleinrock developed queueing theory. Showed effectiveness of packet-switching
- ❑ 1964: Baran's report on packet-switching in military nets
- ❑ 1967: ARPAnet conceived by Advanced Research Projects Agency
- ❑ 1969: First ARPAnet node operational  
First Request for Comment (RFC)

[www.ietf.org](http://www.ietf.org)

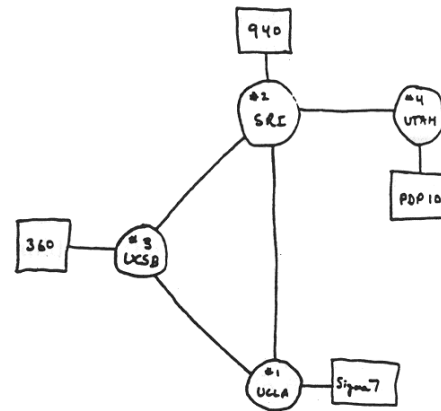

THE ARPA NETWORK

## Student Questions

# History of Internet (Cont)

- ❑ Early 1990s: HTML, HTTP: Berners-Lee
- ❑ 1994: Mosaic, later Netscape
- ❑ 2007:
  - ~500 million hosts
  - Voice, Video over IP
  - P2P applications: BitTorrent (file sharing) Skype (VoIP), PPLive (video)
  - Video applications: YouTube, gaming
  - Wireless, Mobility

## Student Questions

# Key Concepts

- ❑ **Internet Protocol (IP):** Protocol
- ❑ **Address:** All systems have an IP address, for example, 125.36.47.23
- ❑ **Name:** All systems have a human readable name, e.g., scorio.cec.wustl.edu, ibm.com.
- ❑ Technically called **DNS (domain name systems)** name. Details will be introduced later.
- ❑ **IETF:** Internet Engineering Task Force. Make standards for Internet. IETF.org
- ❑ **RFC:** Request for comments. Documents that describe Internet protocols.

## Student Questions

# Summary

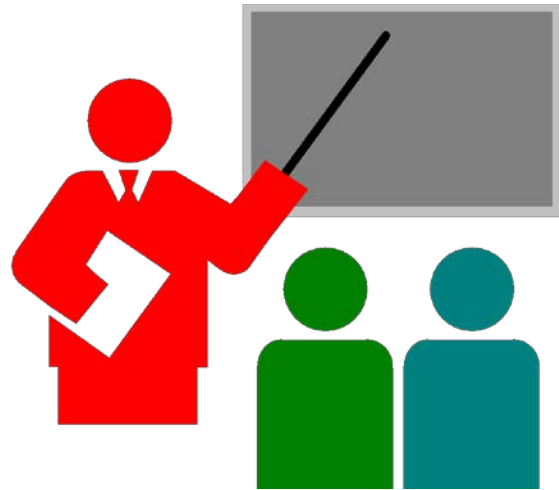

1. Most common medium is **UTP**, wireless, fiber
2. **Internet** is a network of networks
3. Enterprise, **access**, and **core** networks
4. Performance Measures: **Delay**, **Throughput**, **Loss Rate**
5. Protocol Layers: **ISO** and **TCP/IP** reference models

Ref: Read entire Chapter 1 and try R1-R28 8<sup>th</sup> Edition.

## Student Questions

# Lab 1: Internet and Wireshark

[6 points]

1. Find the IP address of your computer (ipconfig, ifconfig)
2. Find the IP address of [www.wustl.edu](http://www.wustl.edu) (ping)
3. Measure delay from your computer to [www.wustl.edu](http://www.wustl.edu) (ping or tracert)

For all cases submit the screen snapshot showing the command used and the output. (Use Alt-Print-screen to capture a window to clipboard and then paste to word)

## Student Questions

- How do you measure delay from computer to website? What is tracert?

*Type these commands in a Windows command prompt box and see what happens. E.g., try 'tracert www.wustl.edu'  
They work similarly in Mac and Linux.*

---

# Lab 1 (Cont)

## 4. Download Wireshark,

<https://www.wireshark.org/download.html>

- Install it on your laptop.
- If you are using a windows computer, you will also need npcap (Packet Capture Tool) from nmap.org
- Start Wireshark and start logging
- Tracert to [www.google.com](http://www.google.com)
- Stop logging. Capture the current screen and submit.  
Do not worry about the part of the trace that is no longer on the screen.
- Q1: List 3 protocols that you see in the packet trace.
- Q2: What is the internet address of [www.google.com](http://www.google.com) from the trace?

## Student Questions

# Reading List

- Read Chapter 2 of the textbook for the next class.

## Student Questions



# Acronyms

- ❑ APDU      Application Packet Data Unit
- ❑ ARPAnet    Advanced Research Project Agency Network
- ❑ ASCII      American Standard Code for Information Interchange
- ❑ AT&T      American Telephone and Telegraph
- ❑ CBR        Constant Bit Rate
- ❑ CIA        Confidentiality, Integrity, Access
- ❑ DNS        Domain Name Service
- ❑ DoS        Denial of Service
- ❑ DPDU      Datalink Packet Data Unit
- ❑ DSDU      Datalink Service Data Unit
- ❑ DSL        Digital Subscriber Line
- ❑ FDM        Frequency Division Multiplexing
- ❑ FTP        File Transfer Protocol
- ❑ FTTH      Fiber to the host
- ❑ GHz        Giga Hertz
- ❑ HFC        Hybrid Fiber Coax

## Student Questions

# Acronyms (Cont)

- ❑ HTML Hyper-Text Markup Language
- ❑ HTTP Hyper-Text Transfer Protocol
- ❑ IEEE Institution of Electrical and Electronics Engineers
- ❑ IETF Internet Engineering Task Force
- ❑ IP Internet Protocol
- ❑ ISO International Standards Organization
- ❑ ISP Internet Service Provider
- ❑ kHz Kilo Hertz
- ❑ LAN Local Area Network
- ❑ LTE Long Term Evolution
- ❑ MAN Metropolitan Area Network
- ❑ MHz Mega Hertz
- ❑ NPDU Network Protocol Data Unit
- ❑ NSDU Network Service Data Unit
- ❑ OSI Open System Interconnect
- ❑ PC Personal Computer

## Student Questions

# Acronyms (Cont)

- ❑ PDU Protocol Data Unit
- ❑ PhSDU Physical Service Data Unit
- ❑ PON Passive Optical Network
- ❑ PPDU PHY protocol data unit
- ❑ PSDU PHY Service data unit
- ❑ RFC Request for Comments
- ❑ SAPs Service Access Points
- ❑ SDU Service Data Units
- ❑ SPDU Session Protocol Data Unit
- ❑ SSDU Session Service Data Unit
- ❑ STP Shielded Twisted Pair
- ❑ TCP Transmission Control Protocol
- ❑ TDM Time Division Multiplexing
- ❑ TFN Tribe Flood Network
- ❑ TP Twisted Pair
- ❑ TSDU Transport Service Data Unit

## Student Questions

# Acronyms (Cont)

- ❑ TV            Television
- ❑ UDP        Universal Data Protocol
- ❑ UTP        Unshielded Twisted Pair
- ❑ VoIP       Voice over IP
- ❑ WAN        Wide Area Network
- ❑ WiFi       Wireless Fidelity

## Student Questions

**Scan This to Download These Slides**



Raj Jain

<http://rajjain.com>

[http://www.cse.wustl.edu/~jain/cse473-22/i\\_1cni.htm](http://www.cse.wustl.edu/~jain/cse473-22/i_1cni.htm)

**Student Questions**

# Related Modules



CSE 567: The Art of Computer Systems Performance Analysis

[https://www.youtube.com/playlist?list=PLjGG94etKypJEKjNAa1n\\_1X0bWWNyZcof](https://www.youtube.com/playlist?list=PLjGG94etKypJEKjNAa1n_1X0bWWNyZcof)

CSE473S: Introduction to Computer Networks (Fall 2011),

[https://www.youtube.com/playlist?list=PLjGG94etKypJWOSPMh8Azcg5e\\_10TiDw](https://www.youtube.com/playlist?list=PLjGG94etKypJWOSPMh8Azcg5e_10TiDw)



CSE 570: Recent Advances in Networking (Spring 2013)

<https://www.youtube.com/playlist?list=PLjGG94etKypLHyBN8mOgwJLHD2FFIMGq5>

CSE571S: Network Security (Spring 2011),

<https://www.youtube.com/playlist?list=PLjGG94etKypKvzfVtutHcPFJXumyyg93u>



Video Podcasts of Prof. Raj Jain's Lectures,

<https://www.youtube.com/channel/UCN4-5wzNP9-ruOzQMs-8NUw>

## Student Questions