

PartyBox

Sarah Chen
Lydia Reader
Graham Rubin
Nathan Schmetter (TA)

A three dimensional display of LEDs that creates a visual display in time to live music, following the rhythm and pitch of the song.

Objectives: Lighting of LEDs in time to the music, varied library of displays that can be changed by pushing a button, transition between standby and music

Budget: \$110.67

Supplies & Theory

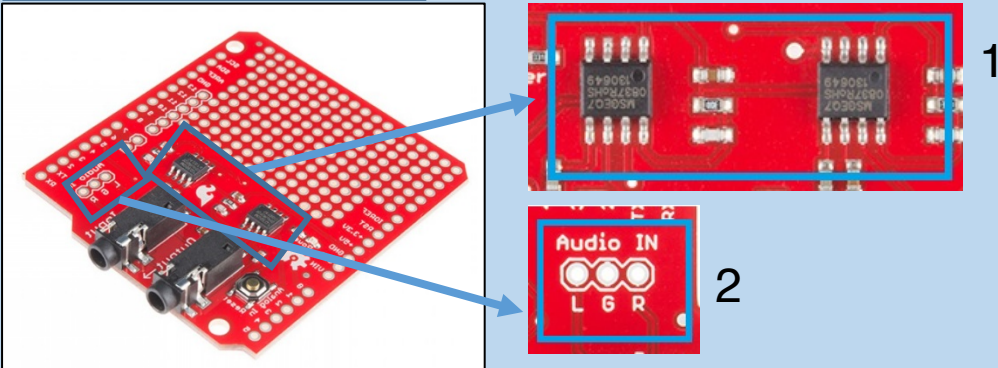

Spectrum Shield:
(1) two MSGEQ7 ICs that are seven band graphic equalizers which process the frequency for us (2) an audio in header that allows us to take in unprocessed audio.

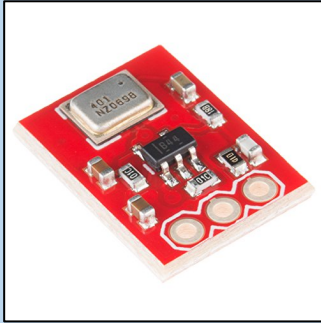

MEMS Microphone Breakout Board

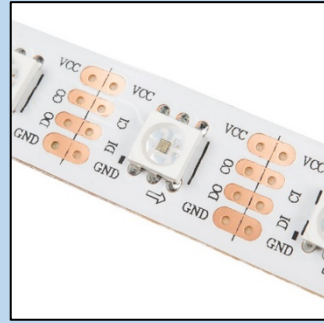

LED strip – close up

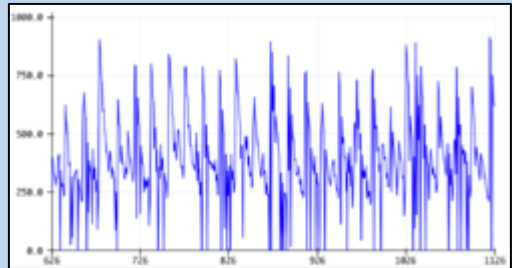

An example of one frequency band's readings. Using the average amplitude as a threshold, we calculate the tempo by averaging the time in ms that the amplitude is above the threshold.

Circuit Diagram

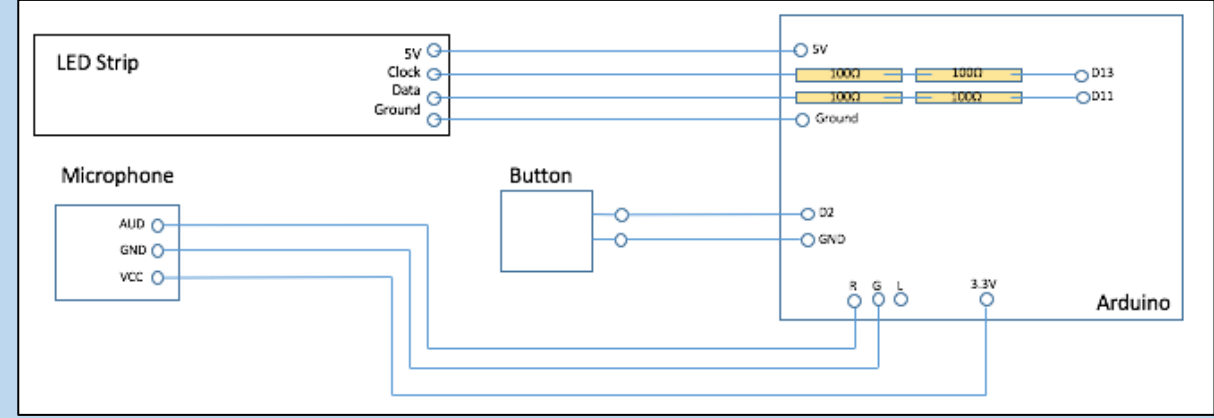

Problems & Solutions



Final design

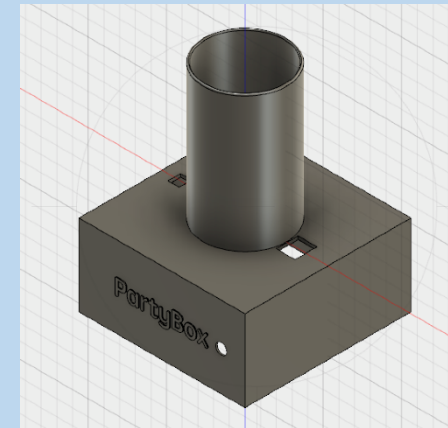

Original design

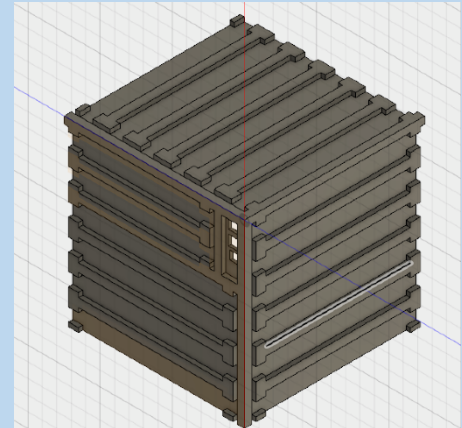

Because the LEDs and the soldered locations are extremely fragile, we could not use our original cube idea as it put too much strain on the soldered connections and resulted in a short circuit.