

MODULE 6

EVOLUTION OF MODELS FOR TRICKLE BED REACTORS AND THEIR EXPERIMENTAL VALIDATION

Objectives of CREL since 1974

- Education and training of students in multiphase reaction systems
- Advancement of reaction engineering methodology via research
- Transfer of state-of-the-art reaction engineering to industrial practice

CREL Sponsors and Collaborators

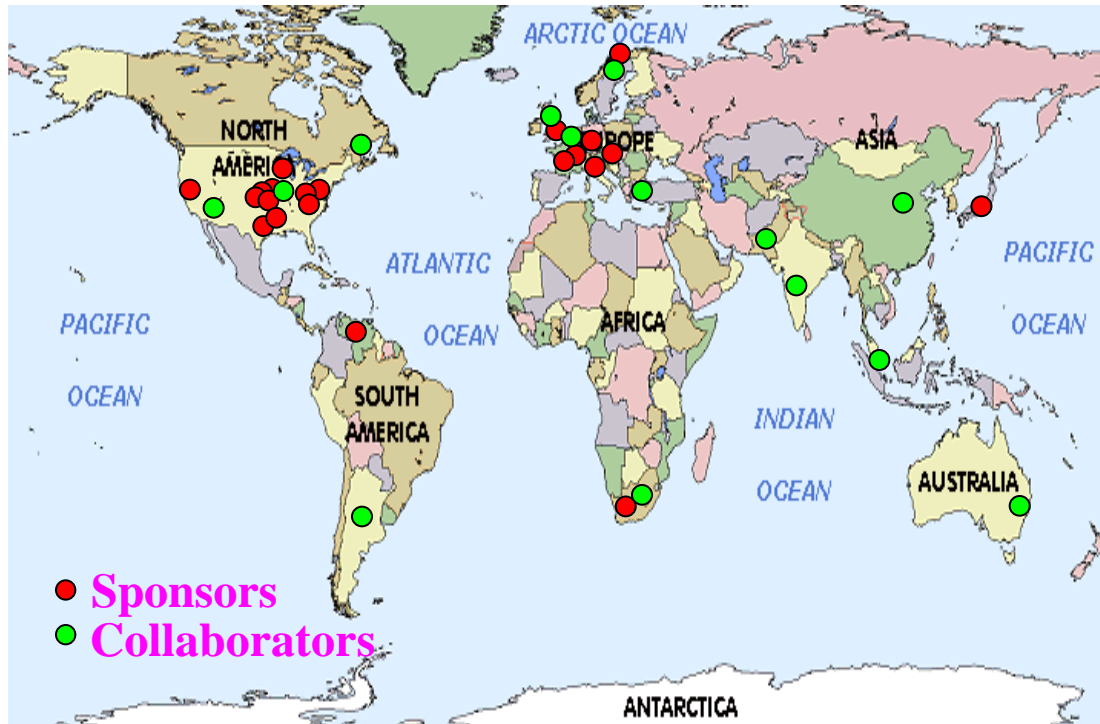

Industrial Sponsors

ADM	IFP
ABB Lummus	Ineos Nitriles
Air Products	Intevap
Bayer	Johnson Matthey
BP	Marathon Oil
Chevron Texaco	Mitsubishi
ConocoPhillips	Praxair
Corning	Sasol
Dow Chemical	Shell
Dupont	Statoil
Enitechnologie	Syntroleum
EastmanChemicals	Total
Exxon - Mobil	UOP

Governmental Sponsors

DOE, NSF, USDA

Packed catalyst beds with two phase flow are used in many heterogeneous catalytic processes. Models evolved from empirical with experimental validation on reactor scale via phenomenological multiscale analysis to fundamental with sophisticated validation on all scales

TRICKLE BED REACTOR

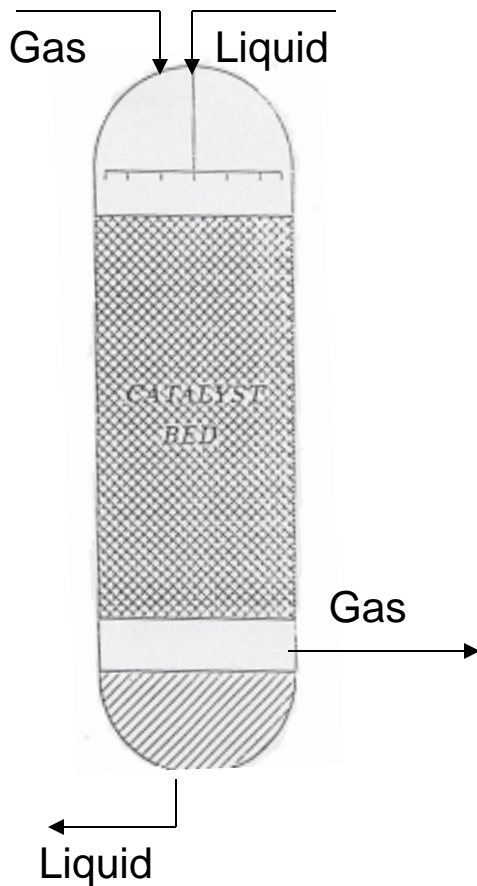

PACKED BUBBLE COLUMN

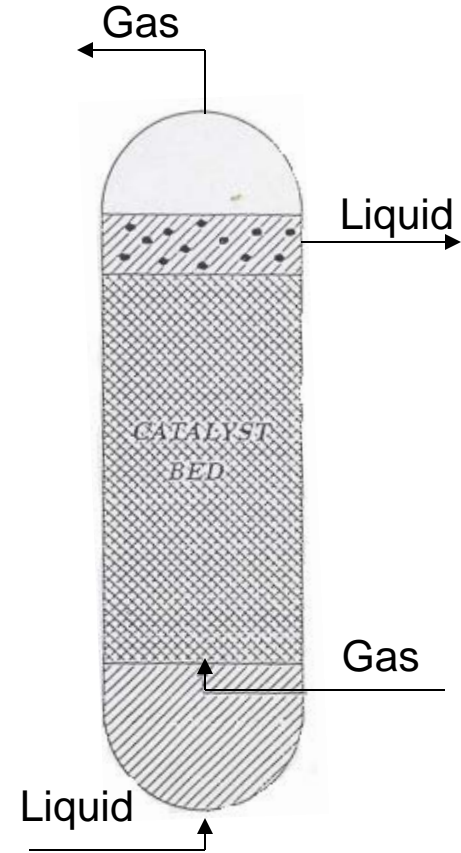

TRICKLE BED AND PACKED BED BUBBLE COLUMN UPFLOW REACTORS: Topics Studied and Modeled

- a. Mode of operation
- b. Phenomena affecting performance
- c. Processes used for
- d. Heat removal strategies

A. TRICKLE BED REACTORS

- a. Flow regimes
- b. Pressure drop and holdup
- c. Transport coefficients
- d. Liquid-solid contacting
- e. Catalyst utilization (effectiveness)
- f. Scale-up strategy (liquid limiting reactant)
- g. Packing laboratory reactors
- h. Axial dispersion
- i. Incomplete contacting and global liquid mal-distribution
- j. Catalyst utilization and scale-up for gas limiting reactions

B. PACKED UPFLOW BUBBLE COLUMNS

- a. Flow regimes
- b. Prediction of performance
- c. Comparison with trickle beds

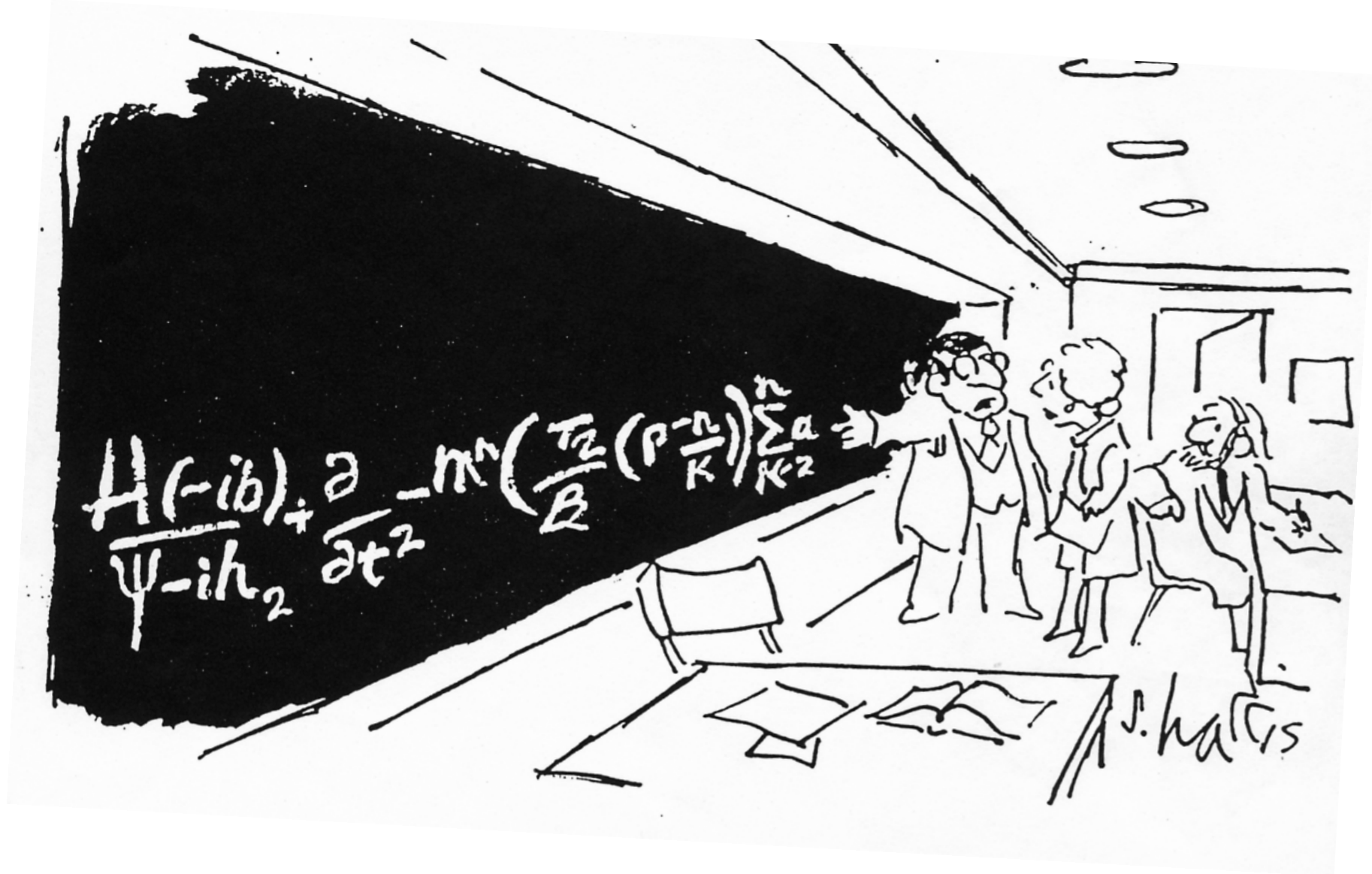

“But this *is* the simplified version for the general public”.

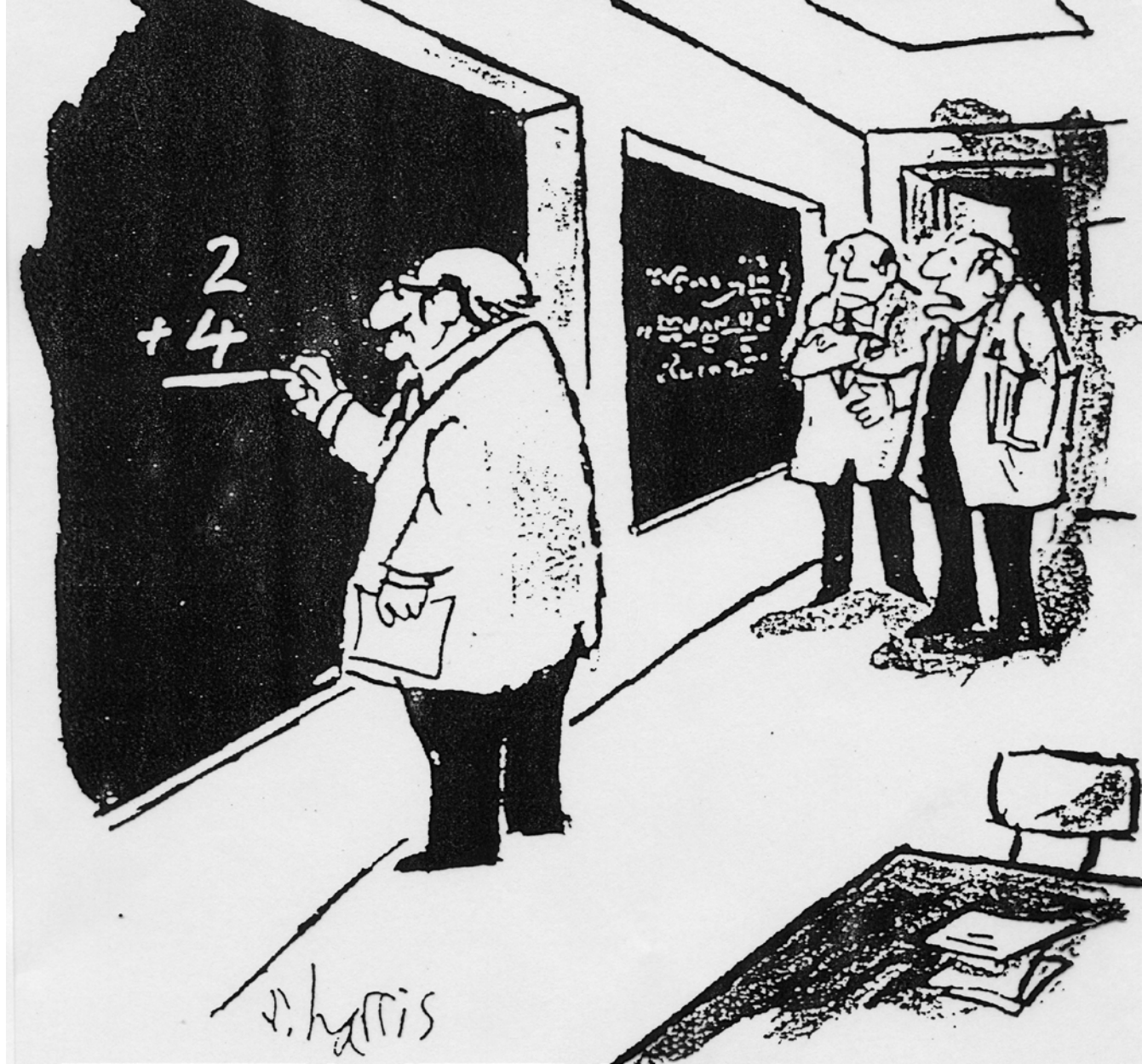

“He was very big in Vienna”.

Multiscale Phenomena Affecting TBR Performance

Co-current gas-liquid down-flow in a packed bed

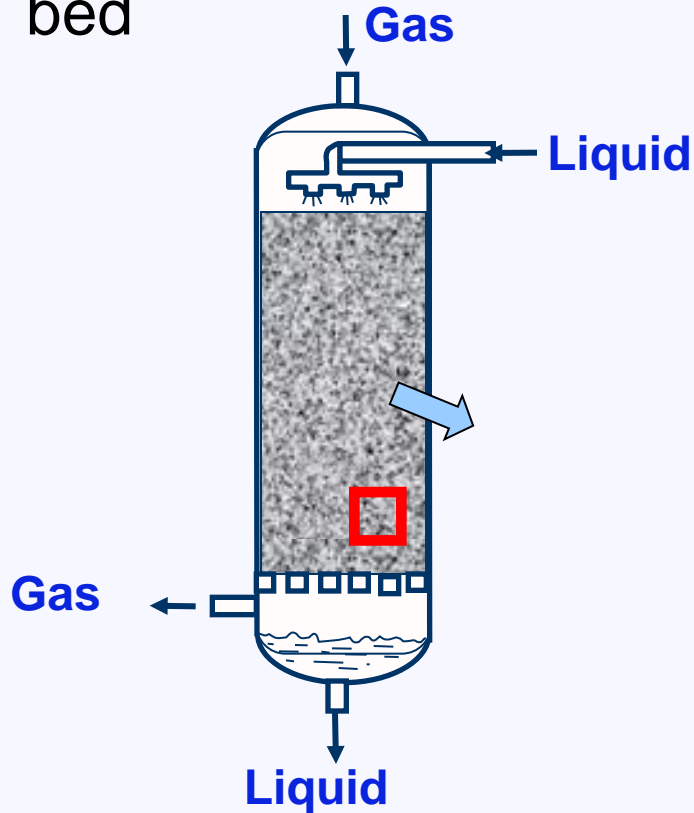

Macro (bed) scale



Meso scale

$$0.001 < G_m < 2 \text{ kg/m}^2\text{s}$$

$$0.08 < L_m < 25 \text{ kg/m}^2\text{s}$$

Porous catalyst:

$$0.08 < d_p < 0.4 \text{ cm}$$

Bed height:

0.2 - 20 m

LHSV: 0.5 to 10 hr⁻¹

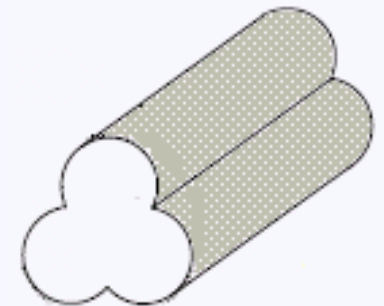

Micro (particle) scale

Volumetric productivity in a TBR



- Average rate influenced by reactor scale contacting pattern (*liquid distribution*) and phase RTD
- *Flow regime* effects the phase holdups and inter-phase transport coefficients.

$$\left(\frac{F_P}{V}\right) = \left(\frac{\text{moles of product}}{\text{TBR volume}}\right) = \frac{p}{a} \left(-\overline{R_A}\right)_{obs} = (\text{If PFR assumption holds}) \frac{(p/a)}{\frac{1}{X_A} \int \frac{dX_A}{(1-\varepsilon_B)(-R_A)_{obs}}}$$

$$\left(-R_A\right)_{obs} = \left(\begin{array}{c} \text{Average Rate} \\ \text{Per Unit Volume} \\ \text{of Particle} \end{array}\right) = \underbrace{(\text{Total Effectiveness Factor})}_{\text{External mass transfer resistance}}$$

$$\left(\begin{array}{c} \text{Rate Evaluated at} \\ \text{Particle Outside} \\ \text{Surface Conditions} \end{array}\right) = \underbrace{\left(-R_A\right)_{obs}}_{\text{Local concentration field}}$$

- External mass transfer resistance (*VLE data, transfer parameters estimates...*)
- Intraparticle mass transfer and kinetic resistance (*particle scale models, transfer parameters*)
- External catalyst surface wetting in a bed (*phenomenological and CFD models*)

- Local concentration field

TBR Performance Assessment: Multi-Scale Approach

- TBR performance affected by particle scale & reactor scale flow phenomena
- Need to couple: 1) reactor scale CFD model; 2) particle scale models

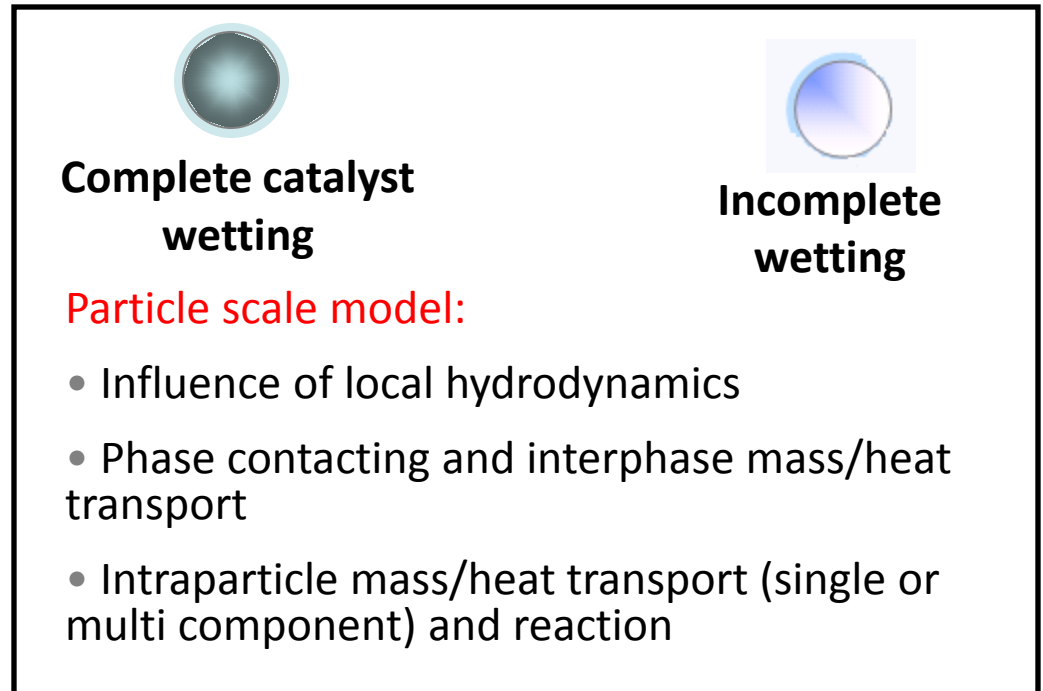
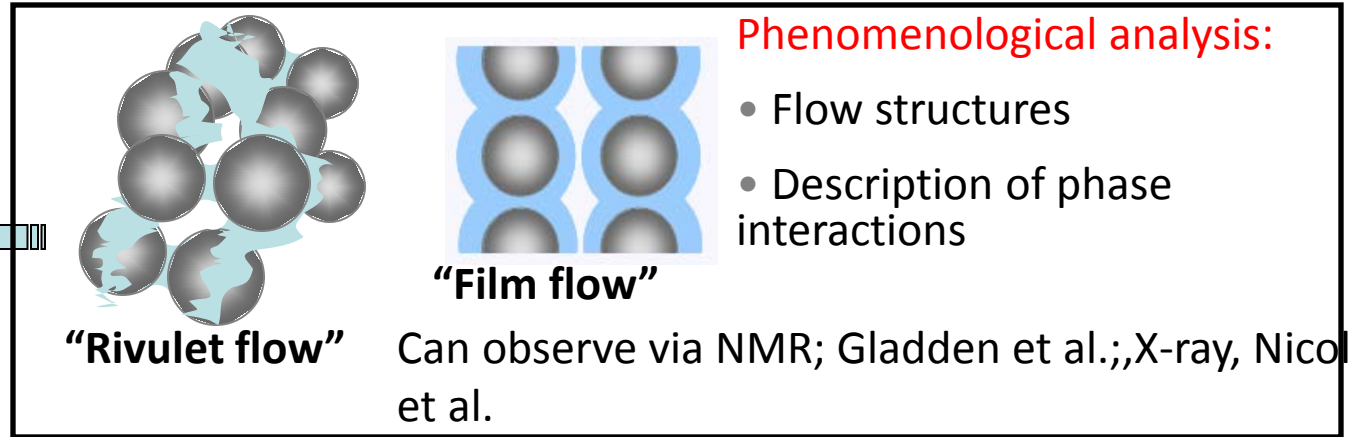
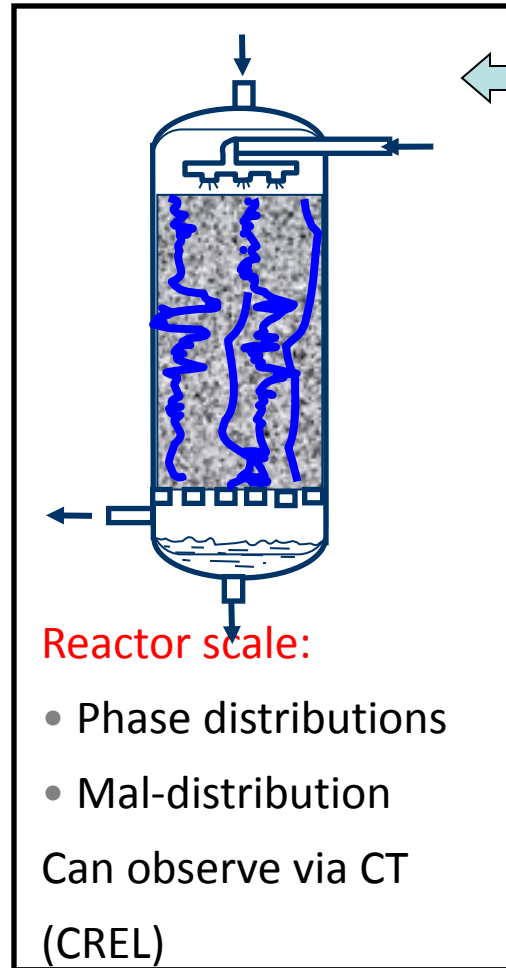

Partial External Wetting

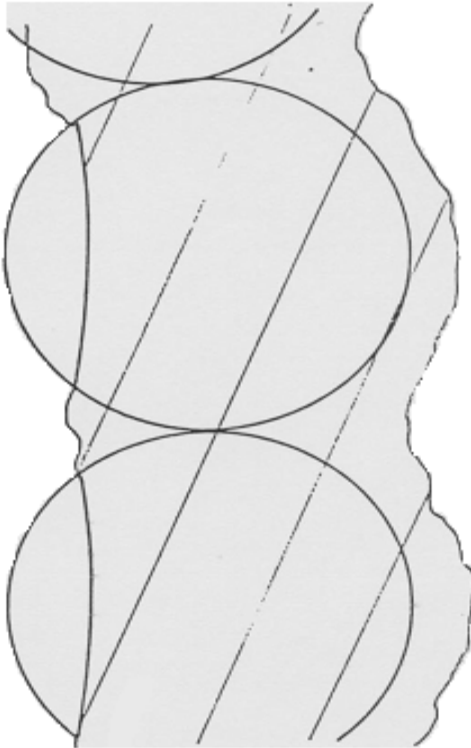

$$L < 3 \text{ kg} / \text{m}^2 \text{ s} \text{ or } u_L < 0.3 \text{ cm/s}$$

Mills, CREL (1980)

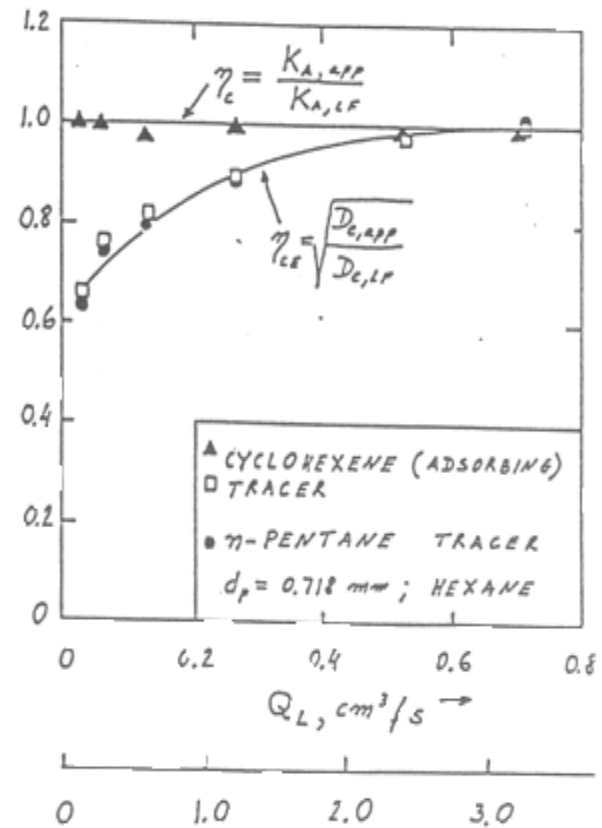

L(kg/m²s)

Dependence of Apparent Rate Constant (k_{app}) on Transport (k_{ls}, η_p) and Kinetic Parameters (k_v)

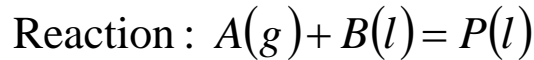

Liquid limiting reactant (nonvolatile) – Case of completely wetted catalyst

Kinetic rate
(per unit catalyst volume) : $k_v B$ ($mol/m^3 \text{ cat.s}$)

Rate in catalyst
(per unit reactor volume) : $k_v \eta_p B_s (1 - \varepsilon_B)$ ($mol/m^3 \text{ react.s}$)

Transport rate
(per unit reactor volume) : $k_{ls} (B_l - B_s) a_p$ ($mol/m^3 \text{ react.s}$)

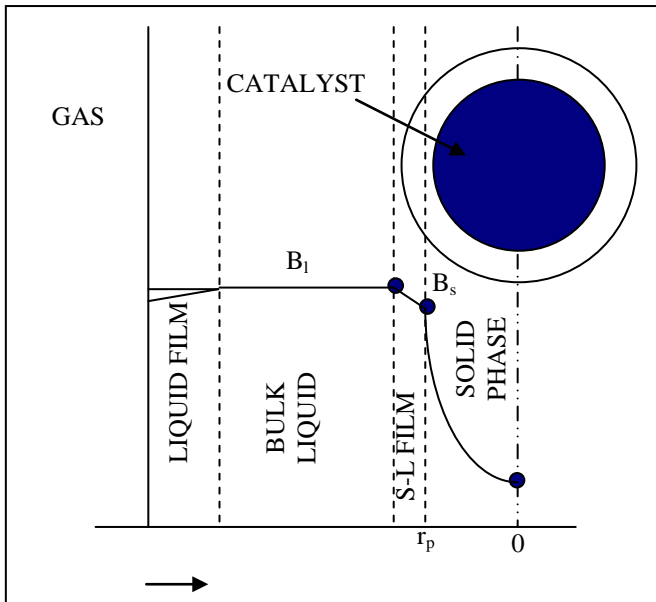

$$\eta_p k_v (1 - \varepsilon_B) B_1 - k_{app} B_L = \frac{B_L}{\frac{1}{k_{ls} a_p} + \frac{1}{\eta_p k_v (1 - \varepsilon_B)}}$$

Dependence of Particle Overall Effectiveness Factor (η_{TB}) for Partially Wetted Pellet on Contacting Efficiency (η_{CE})

Liquid reactant limited reaction (Non volatile liquid)

$$\eta_{TB} = \frac{\text{(Observed local reaction rate in partially wetted particle)}}{\text{(Ideal local reaction rate on completely wetted catalyst)}}$$

$$\Lambda_p = \phi = \sqrt{\frac{\text{Local reaction rate in particle in absence of transport effects}}{\text{Maximum transport rate into catalyst}}}$$

$$\eta_{CE} = \left(\text{Fraction of external catalyst area effectivelly wetted by liquid} \right)$$

Reactor performance equation:

Plug flow assumed

$$X_L = 1 - \exp\left(-\frac{3600(1 - \varepsilon_B)k_{app}}{LHSV}\right) \quad k_{app} = \frac{k_v \eta_{CE}}{\frac{\Lambda_p}{\tanh(n_l \Lambda_p / \eta_{CE})} + \frac{\Lambda_p^2}{Bi_w}}$$

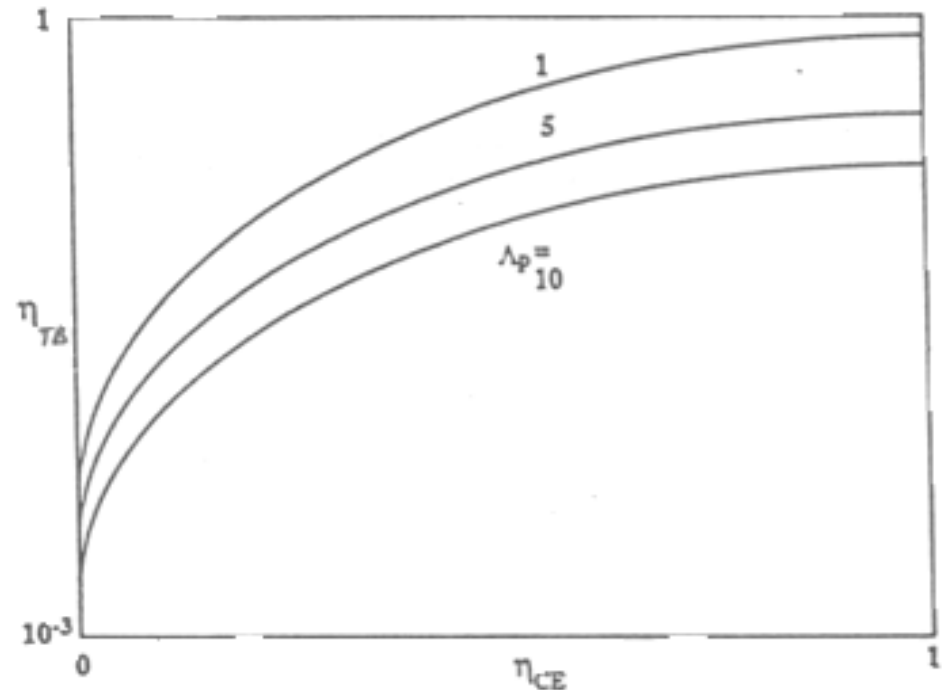

For liquid limiting reactant

$$k_{app} = k_v \eta_o = \frac{k_v \eta_{CE}}{\frac{\Lambda_P}{\tanh(\eta_I \Lambda_P / \eta_{CE})} + \frac{\Lambda_P^2}{Bi_w}}$$

Indeed an increase in η_{CE} , which results from the increase in L, always increases k_{app}

Deviations from scale-up predictions can be caused by:

- Reaction not nonvolatile liquid limited
- Global liquid maldistribution or coring

Use of Plug Flow Model for Scale-Up

Example: nonvolatile liquid, 1st order

$$x_B = 1 - \exp\left(-\frac{3600(1 - \varepsilon_B)k_{app}}{LHSV}\right)$$

$$LHSV = \frac{3600u_L}{H_R}$$

Using i) same catalyst activity

ii) same size particles

iii) same packing procedure (ε_B)

iv) same feed

v) same temperature

RULE: The plant reactor (P) and laboratory reactor (L) should yield same performance (x_B) at same $LHSV_P = LHSV_L$

Since the plant reactor is always taller $H_{R_P} > H_{R_L}$ then $u_{L_P} > u_{L_L}$
So that transport resistances are always diminished in the large reactor.

Under what conditions is that so?

SIE (1991);Shell

$$k_{app} = \eta_0 k$$

Scale \uparrow , η_{CE} \uparrow , η_0 \uparrow , k_{app} \uparrow .

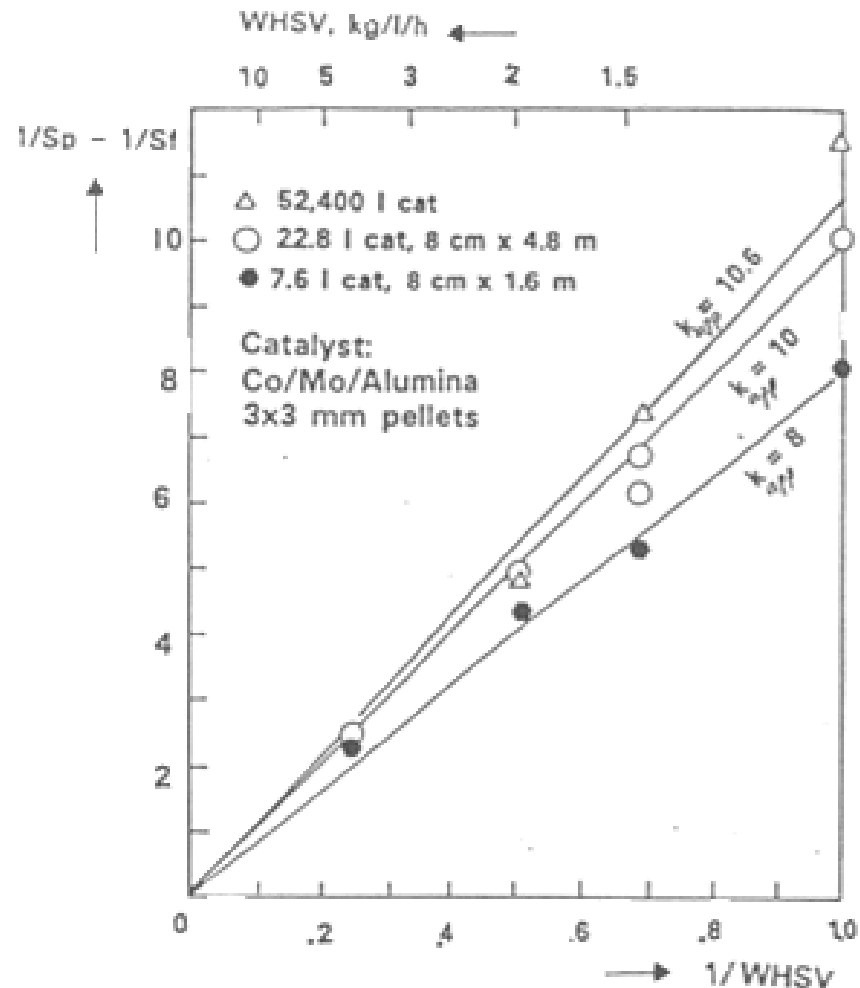

Comparison of a commercial reactor with pilot reactors of different lengths in gas oil hydrodesulfurization. The results are plotted as a pseudo-second-order reaction, which has been found to be an adequate way of describing the space velocity/sulfur removal relationship for this multicomponent mixture. S_f and S_p represent the sulfur contents of feed and product, respectively, in %w. k is the rate constant for hydrodesulfurization.

Comparison of commercial hydro-treater with lab/bench reactor

	Commercial	Lab/Bench
Catalyst Volume (m ³)	248	0.001
Catalyst Bed Length (m)	25.0	1.3
Reactor diameter (m)	3.35	0.025
Liquid flow rate (kg/sec)	41.70	0.000069
Liquid mass velocity (kg/m ² sec)	4.73	0.137
Gas mass velocity (kg/m ² sec)	0.61	0.0177
Gas flow rate (kg/sec)	5.4	0.00009
Liquid phase Reynolds number	10.48	0.303
Gas phase Reynolds number	72.50	2.10
LHSV, hr ⁻¹	1.39	1.39

$$\frac{H_{R,C}}{H_{R,L}} = \frac{2.5}{1.3} = 19.2$$

$$\frac{\eta_{CE,C}}{\eta_{CE,L}} = \frac{1}{0.683} = 1.46$$

$$k_{app} = \frac{k_v \eta_{CE}}{\frac{\Lambda_P}{\tanh(\eta_I \Lambda_P / \eta_{CE})} + \frac{\Lambda_P^2}{Bi_w}}$$

$$x_L = 1 - \exp\left(-\frac{3600(1 - \varepsilon_B)k_{app}}{LHSV}\right) \quad \text{Liquid limited reaction}$$

Consequences of Liquid Maldistribution

Poor micro-distribution:

- Regions of unwetted catalyst
- Delayed gas dissolution in liquid

Poor macro-distribution:

- Radial temperature gradients
- Gas-liquid separation further down bed
- H₂ deficiency in liquid further down bed

Overall impact:

- Apparent catalyst activity loss
- Failure to meet products specs



Effect of Reactor Scale Maldistribution on Performance (HDS)

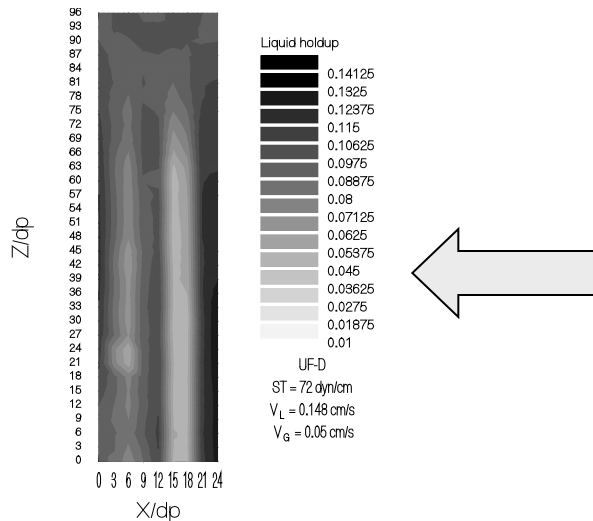
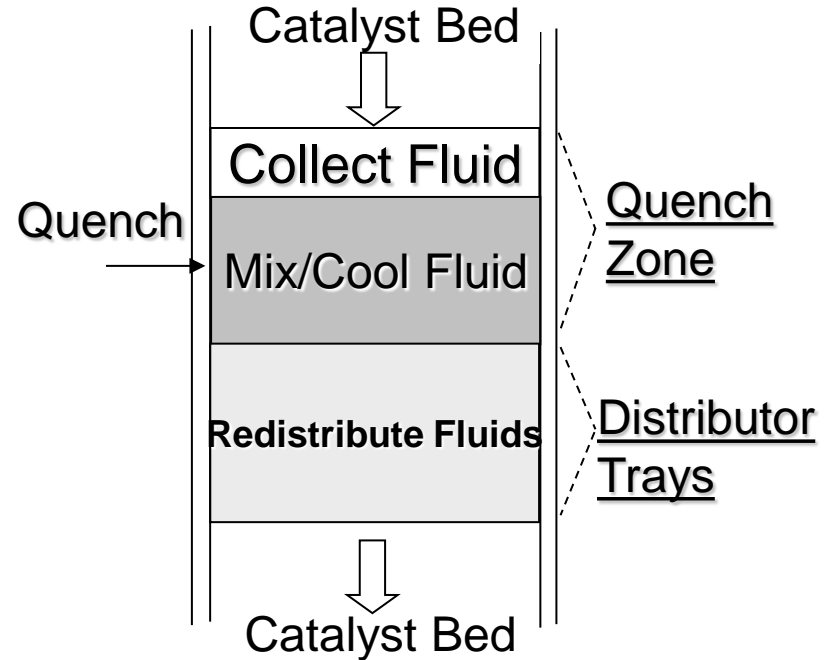
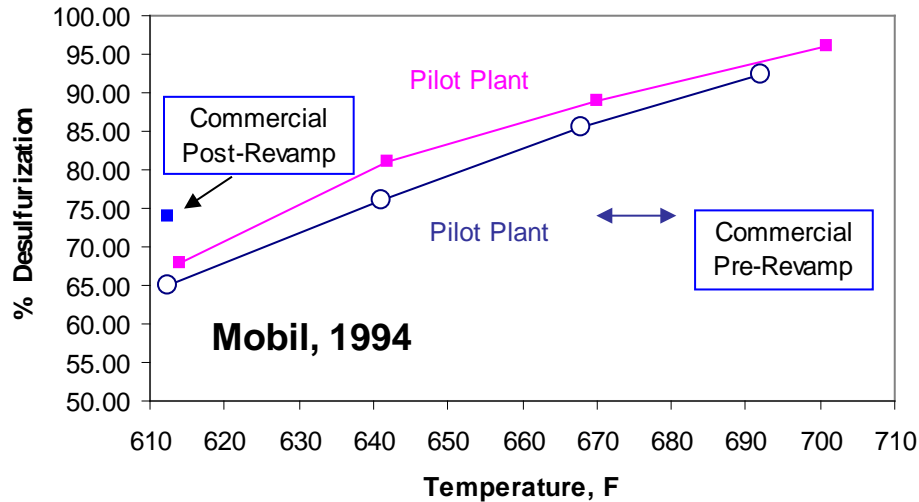

Flow Simulation:
Liquid holdup distribution
(Uniform liquid and gas inlet)

Partial wetting : Gas limiting reactant

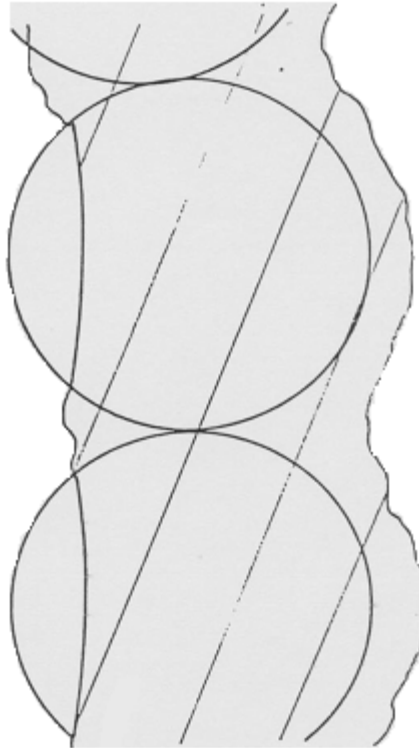

$$L < 3 \text{ kg} / \text{m}^2 \text{ s} \text{ or } u_L < 0.3 \text{ cm/s}$$

For gas limiting reaction (1st order) conversion of liquid is given by (PFR)

$$x_B = \frac{vA^*(1 - \varepsilon_B)3600k_{app}}{B_{lo} LHSV} \quad \text{Pure gas reactant in gas phase}$$

$$k_{app} = \frac{\eta_{CE}}{\frac{\Lambda^2}{Bi_{wG}} + \frac{\Lambda}{\tanh \Lambda}} + \frac{(1 - \eta_{CE})\tanh \Lambda}{\Lambda}$$

Increase in η_{CE} decreases k_{app} and equal LHSV scale-up does not work!! $u_L \uparrow$ $k_{app} \downarrow$

Note: The above gas-limiting reaction can switch to liquid diffusion limited when

$$x_B > 1 - \frac{3\Lambda vA^* D_{ae}}{B_{lo} D_{B_i}}$$

Note: In dried out catalyst particles Thiele modulus may be 100 fold lower than in liquid filled pellet and reaction many fold faster! Locally this can lead to hot spot!!

TBR SCALE-UP Failure based on LHSV=const.

Aldehyde Hydrogenation, Scale-up done based on equal LHSV

DATA	PLANT	LAB
Height (m)	19.4	0.235
Diameter (m)	0.455	0.0341
LHSV (hr⁻¹)	1.3	1.3
U_L (LSV) (mhr⁻¹)	26	0.26
H ₂ FLOW (STD) (m ³ hr ⁻¹)	1000	0.067
GHSV (hr ⁻¹)	312	312
Pressure (bar)	70	70
Temperature (C)	110	110
Bed porosity	0.425	0.425
Catalyst tablets	3/16'' x 1/8''	3/16'' x 1/8''
Conversion (x_B)	0.4	0.9
Contacting efficiency	1.0	0.51

$$\frac{H_P}{H_L} = 100 = \frac{L_P}{L_L} \quad \frac{\eta_{CE,P}}{\eta_{CE,L}} \approx 3$$

$$L_L = 0.06 \text{ kg} / \text{m}^2 \text{ sec} \quad L_P = 6 \text{ kg} / \text{m}^2 \text{ sec}$$

$$k_{app} \approx 0.44 k_{app,L}$$

For **gas limited reaction**, need both LHSV = constant and H_R = constant

Plug Flow Model for Scale-Up in Absence of Maldistribution (LHSV=Const)

Nonvolatile liquid limited reaction 1st order : $A(g) + B(l) = P(l) + G(g)$

$$x_B = 1 - \exp\left(-\frac{3600(1-\varepsilon_B)k_{app}}{LHSV}\right)$$

$$LHSV = \frac{3600u_L}{H_R}$$

$$k_{app} = k_v \eta_o = \frac{k_v \eta_{CE}}{\frac{\Lambda_P}{\tanh(\eta_I \Lambda_P / \eta_{CE})} + \frac{\Lambda_P^2}{Bi_w}}$$

Using: i) same catalyst activity, ii) same size particles, iii) same packing procedure (ε_B), iv) same feed, v) same temperature

Gas limiting reaction (1st order): $A(g) + B(l) = P(l) + G(g)$

Conversion of liquid in PFR is given by:

$$x_B = \frac{vA^*(1-\varepsilon_B)3600k_{app}}{B_{lo}LHSV}$$

$$k_{app} = \frac{\eta_{CE}}{\frac{\Lambda^2}{Bi_{wG}} + \frac{\Lambda}{\tanh \Lambda}} + \frac{(1-\eta_{CE})\tanh \Lambda}{\Lambda}$$

Failure of $LHSV = \text{const}$ Scale-up for Liquid Limited Reaction in a Trickle Bed

- $LHSV = \text{const}$. scale up worked well for previous catalysts but failed for a much more active catalyst in hydrogenation of a non-volatile liquid reactant to the first hydrogenation product which was desired.
- The reason is that the large diameter reactor suffered from liquid maldistribution which with the much more active catalyst led to over-hydrogenation to other products in the regions of locally higher residence times.
- The locally high temperatures were detected at some radial positions partly into the bed well in excess of the adiabatic temperature of the first reaction confirming the above assumption.
- A predictive model would have avoided this!

Trend in TBR Scale-up

- Laboratory scale representation of commercial reactors
- Direct scale-up from laboratory micro reactor to commercial reactor design

Advantages of smaller scale

- Cheaper
- Less material needs
- Lower utility costs
- Less infrastructure
- Safer
- Better working practice

Parameters	Commercial	Pilot	Bench	Micro
Catalyst volume (L)	100,000	10	0.15	0.008
Diameter of bed (cm)	250	4	2	1
Length of bed (cm)	2000	800	50	10
Superficial velocity (cm/s)	1.1	0.4	0.03	0.006
Reynolds Number	55	22	1.4	0.3
Liquid use (L/h)		20	0.3	0.016

More Recent Modeling Approaches

- Prediction of global bed properties like liquid holdup, pressure drop, transport coefficients using the expert system and most comprehensive database assembled by Larachi and colleagues (Multi_R_Designer, Larachi et al. 2000)
- Using statistical description of bed porosity distribution for prediction of flow and holdup distribution by CFD (Euler-Euler) or minimization of energy dissipation (Holub, Jiang, Guo –CREL). Develop 2-D cell network model (Jiang, Guo- CREL)
- Using more detailed mass and energy balances on particle scale and reactor scale and detailed multi component transport to describe steady and transient TBR behavior (Khadilkar , Kuzeljevic–CREL)
- Detailed statistical description of packing, micro scale flow description coupled with macro scale bed CFD (Combest –CREL)

CREL TRICKLE BED WORK MAIN CONTRIBUTORS:

- J. SCHWARTZ (1975) - Amoco / BP
- P.L. MILLS (1980) - DuPont/Texas A&M Kingsville
- A. EL-HISNAWI (1981) - L.A.E.A
- E. BEAUDRY (1985) - Solarex
- P. HANRATTY (1988) - D.M.C. / Aspen / ExxonMobil
- R. HOLUB (1991) - Ethyl / Albemarle
- M. AL-DAHMAN (1993) - Xytel/WUSTL/ MST
- **M. KHADILKAR** (1998) - General Electric/SABIC
- J. WU (1998) - Wuhan Institute of Technology
- **Y. JIANG (2000)** - Conoco / Corning
- J. GUO (2004) - UOP
- **Z. KUZELJEVIC** (2010) - SABIC
- **D. COMBEST** (2012) - Engys Ltd.

Simulation Results: Multiplicity Effects

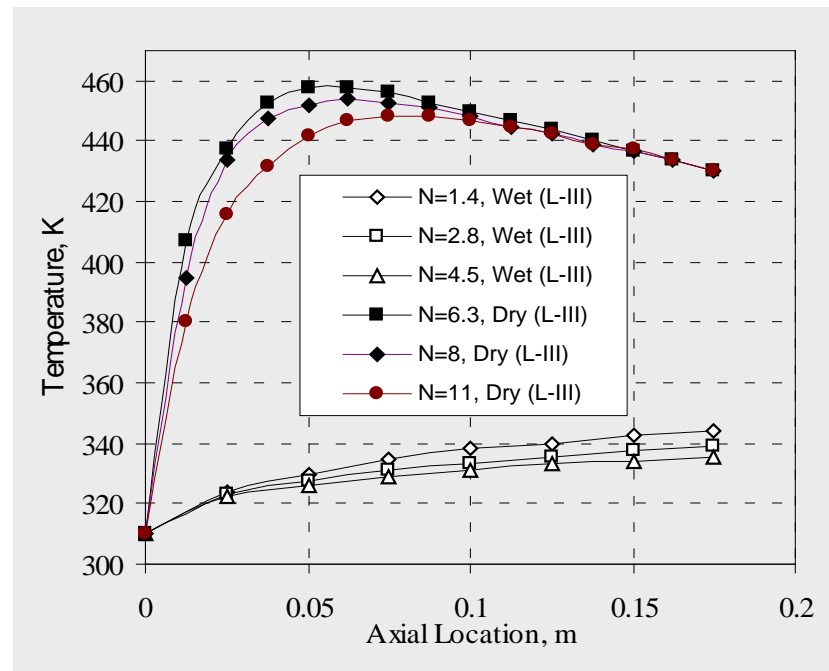
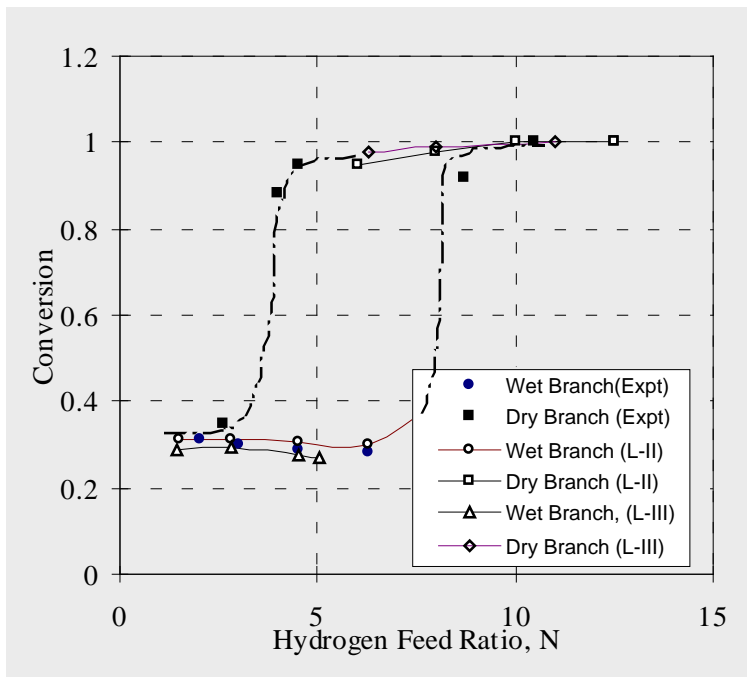

- Hysteresis Predicted
- Two Distinct Rate Branches Predicted (As Observed by Hanika, 1975)
- Branch Continuation, Ignition and Extinction Points
- Wet Branch Conversion (~30 %)
- Dry Branch Conversion (> 95 %)
- Wet Branch Temperature Rise (~10-15 °C)
- Dry Branch Temperature Rise (~140-160 °C)

Data from Hanika et al., (1976)
1D model Khadilkar et al. (1998)

Intra-reactor Wet-Dry Transition

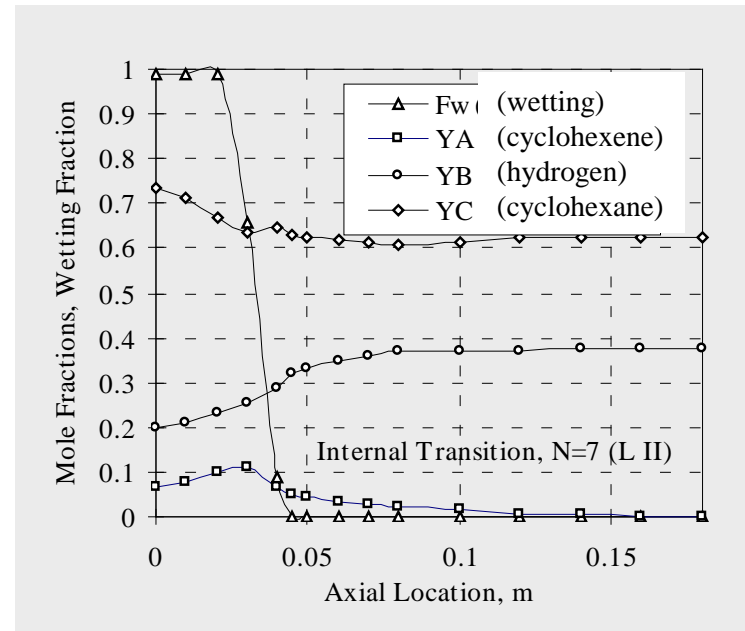
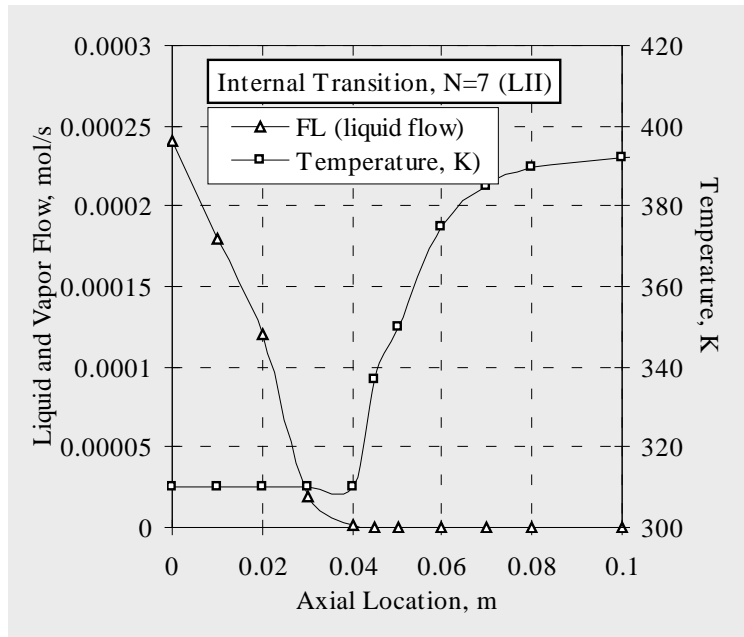

- Abrupt drop in liquid flow
- Temperature rise after liquid-gas transition

- Abrupt change in catalyst wetting
- Cyclohexene and cyclohexane mole fraction show the effect of evaporation and reaction

Khadilkar (CREL), 1998 1D model

Performance Enhancement by Periodic Operation

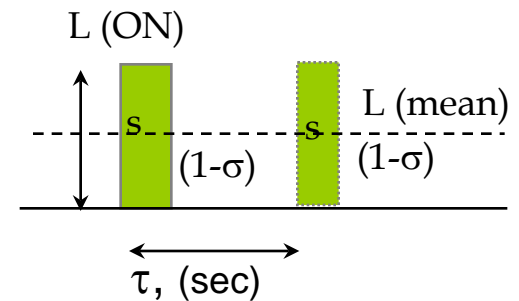
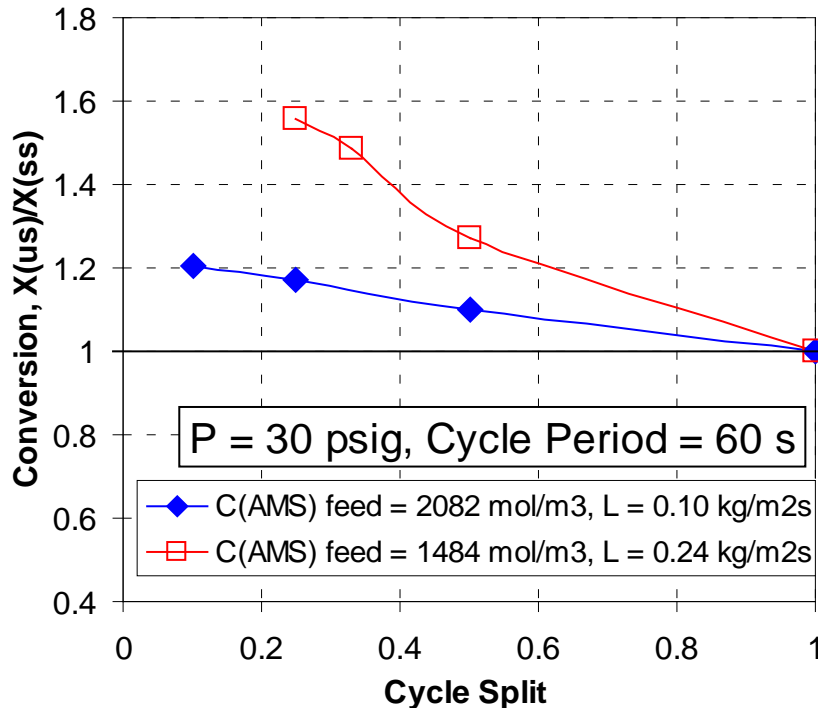

$$L(\text{ON}) = L(\text{mean}) / \sigma$$

**(Khadilkar et al., 1999
1D model)**

Hydrogenation of α -Methylstyrene to Cumene
 -under gas limited conditions at different cycle splits

2-D Rectangular Bed (Liquid Holdup Snapshot)

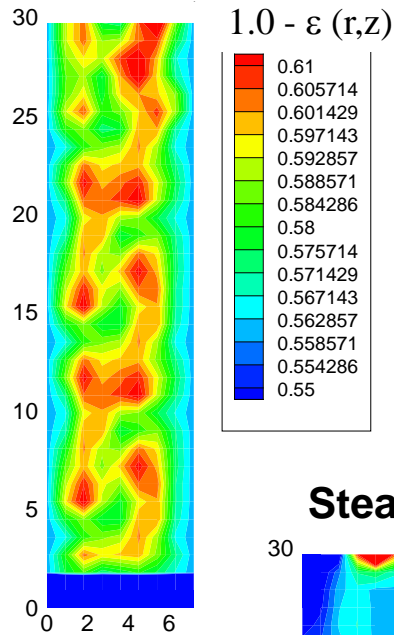

Solid Vol. Fraction

LIQUID PERIODIC OPERATION

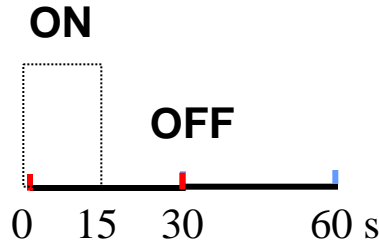

Dimensions:

29.7 cm x 7.2 cm

Distributor:

33 cells (z) x 8 cells (x)

Velocities:

2 cells (L); 8 cells (G)

0.1 cm/s (L)-time averaged

10. cm/s (G)

60s cycle time = 15s turn-on + 45s turn-off

Steady state

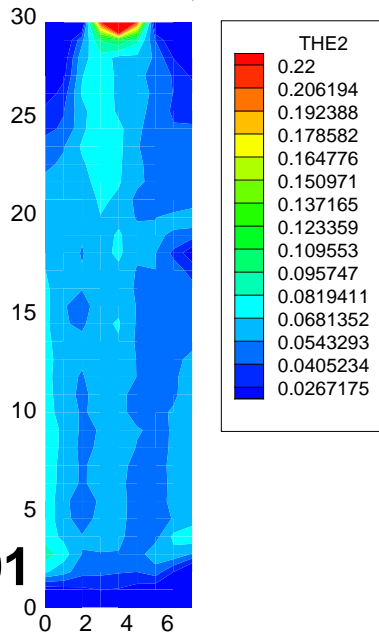

T = 15s

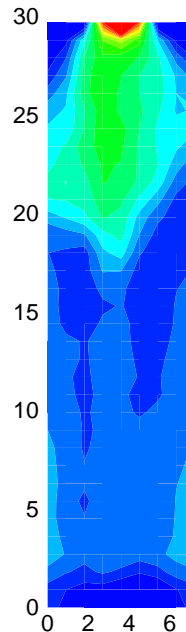

T = 25s

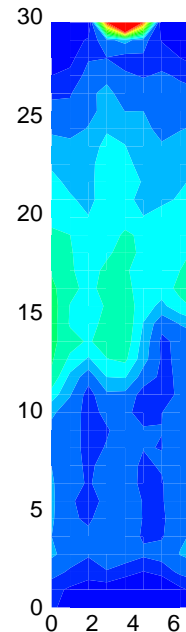

T = 40s

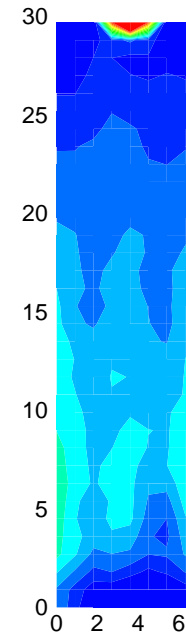

Jiang et al,
AIChEJ 2001

CREL

CONCLUSIONS AND CHALLENGES

- More detailed models that couple the reactor scale and particle scale events and account fully for **momentum conservation**, in addition to energy and species mass, are increasingly available. **Their continued weakness is lack of understanding of bed structure and uncertainties in models for phase interactions.** Data for proper validation on large scale reactors is not available.
- More sophisticated experimental techniques (NMR, X-ray, gamma ray CT, etc.) are being used to generate more detailed pictures of flow and reactant distribution on particle scale and meso scale. **There has been lack of success in using this information to generate 'closure' terms for large scale models. Prediction of reactor runaway is still not feasible.**
- **The wide GAP between academic research and industrial practice is widening. It is aggravated by the diminishing expertise in the multiscale approach.**

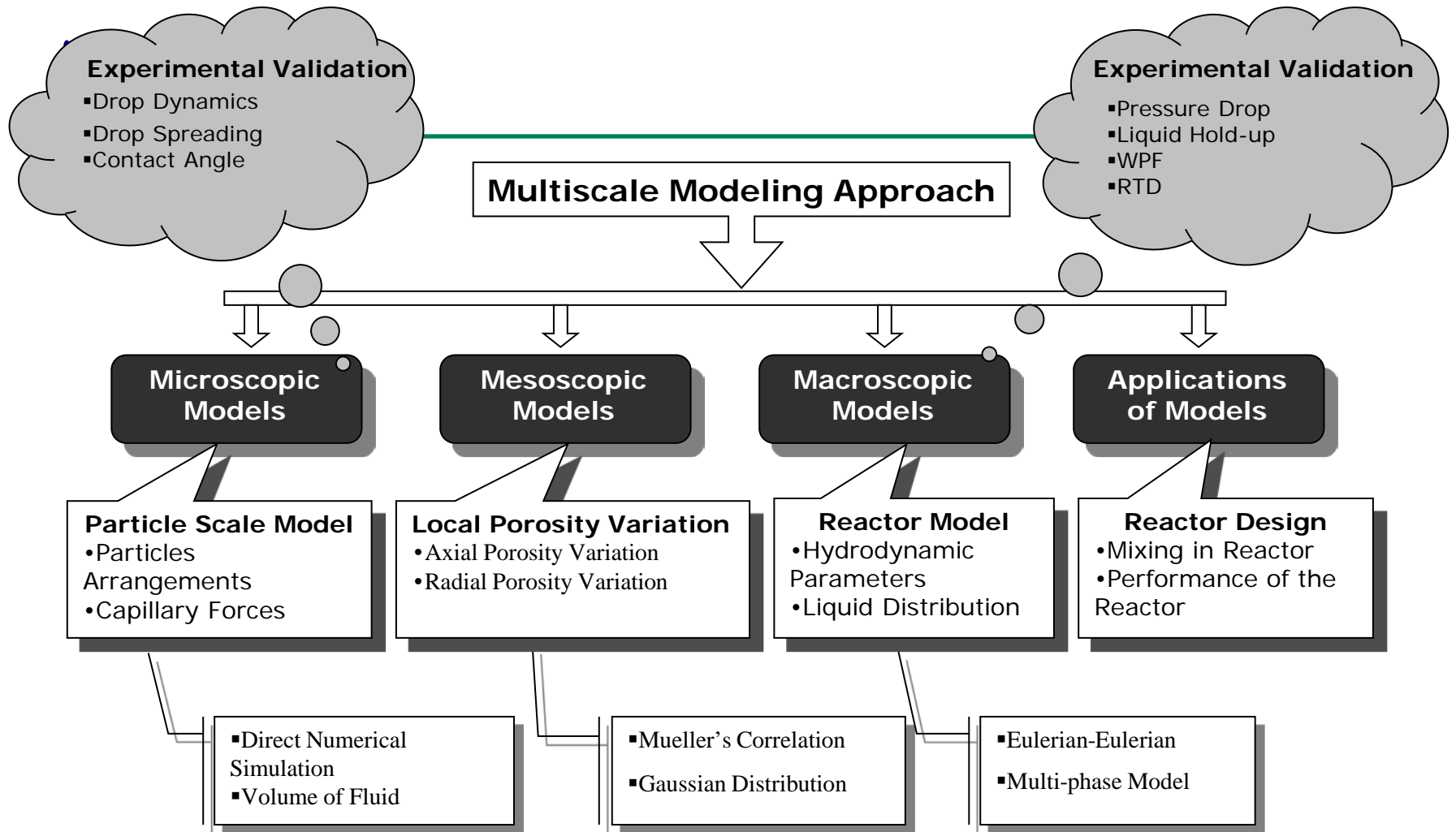

Modeling of Gas-liquid Flows in Trickle Bed Reactors

Gunjal and Ranade (2000)

3D Hydrodynamic Eulerian CFD Model

Model setup:

- Volume averaged equations on the computational grid
- Porosity distribution on the computational grid (CT data; Gaussian)
- Phase interactions closures (two fluid model, statistical hydrodynamics and relative permeability model)
- Account for pressure difference between gas and liquid phase (“capillary closure”)
- Solution strategy (Fluent/Gambit with Matlab and C codes)

Basic input parameters:

- *Ergun parameters (E_1 , E_2 for the bed of interest via one phase flow experiments)*
- *Contact angle (determines likelihood of film vs. rivulet flow)*
- *Liquid phase relative permeability*

CFD based multiphase flow modeling

Mixing-Cell Network Model Concept

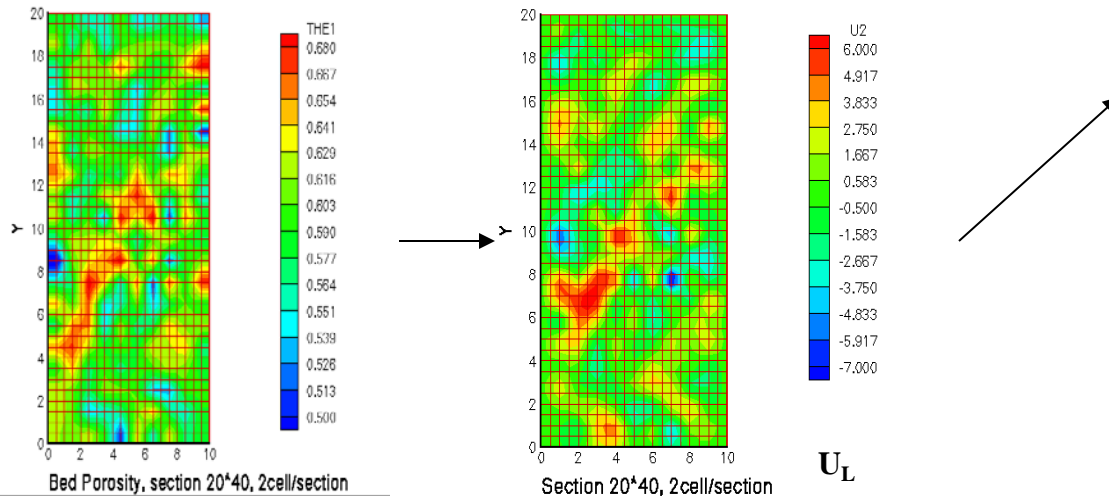
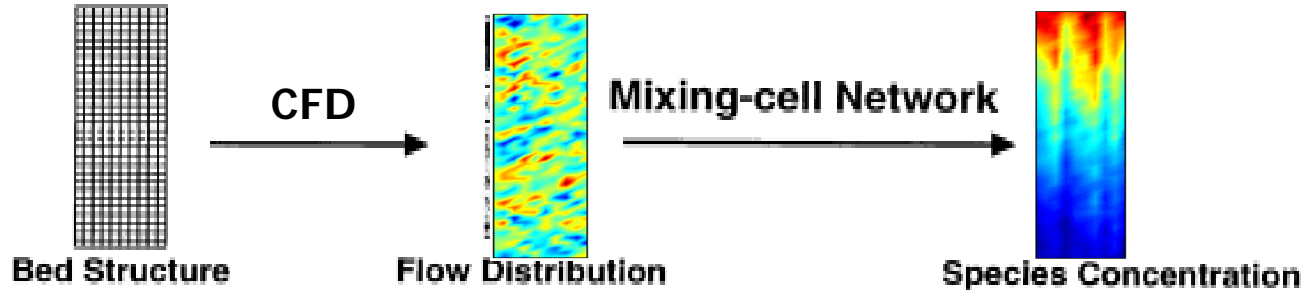

CFD-related work

- Implement the porosity distribution of the bed in k-fluid model
- Validate the k-fluid CFD simulation and evaluate the closures

Jiang, Guo,
Kuzeljevic
CREL , 2000-2010

Liquid Distribution in Trickle Bed Reactors - Experimental Setup

Exit Liquid Distribution

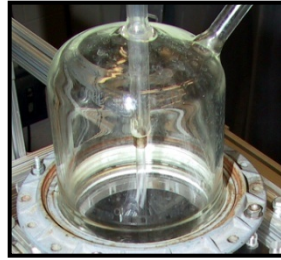

DISTRIBUTOR

Single point
10mm diameter
liquid inlet

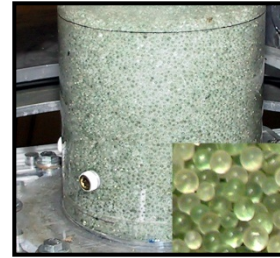

PACKING

6" (14 cm)
Column

$$1 < L/D < 4$$

3mm diameter
glass beads



COLLECTING TRAY

25 cross
sectional areas

Computed Tomography



Computed Tomography

Liquid holdup

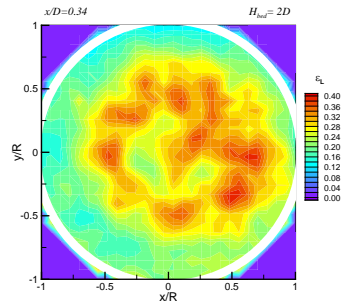

Exit Liquid Distribution

Exit liquid distribution, % of total flux (F_T)

$$U_L = 4 \text{ mm.s}^{-1}, U_G = 0 \text{ m.s}^{-1}$$

$$L/D = 2, F_T = 85 \text{ kg.m}^{-2}.\text{s}^{-1}, Mf = 0.054$$

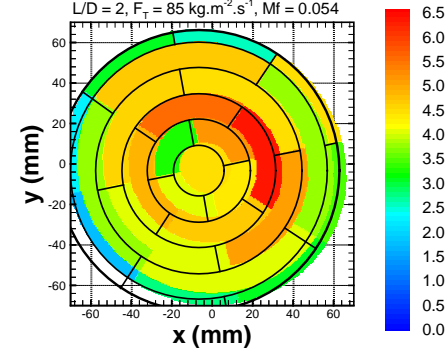

Cross-sectional liquid holdup and exit liquid distribution are compared in the region close to the reactor bottom. Results are in good qualitative agreement even though two different parameters (i.e. liquid holdup and exit liquid fluxes) are compared but that is not always the case. **CFD predictions remain a challenge!**

Micro-Scale Modeling of Packed Beds

Combest (2012) CREL

Packing

- Randomly packed domains of (10^2 - 10^3) cylindrical particles are made from a Monte-Carlo packing algorithm.
- Because the exact location of the faces of the particles are known, computational meshes are accurately constructed.

Modeling

- Micro-scale models of packed beds are based on the Navier-Stokes equations without an Ergun-type pressure closure relation
- More complex conjugate heat transfer models (including heat transport in solids) are being developed

Advanced Hardware Integration

- Because of the size of the sparse matrices produced by these meshes, a computational paradigm shift is necessary to leverage new technology in widely used CFD software.
- Integration of Graphics Processing Units (GPU) to solve these sparse linear systems is being performed with multiple times speedup compared to CPU based linear system solvers.
- Integration of GPU based solvers into OpenFOAM code is currently available.

CONCLUSIONS AND FUTURE CHALLENGES

- More detailed models that couple the reactor scale and particle scale events and account fully for momentum conservation, in addition to energy and species mass, are increasingly available. Their continuous weakness is lack of understanding of bed structure and uncertainties in models for phase interactions. Data for proper validation on large scale reactors is not available.
- More sophisticated experimental techniques (NMR, X-ray, gamma ray CT, etc.) are being used to generate more detailed pictures of flow and reactant distribution on particle scale and meso scale. There has been lack of success in using this information to generate 'closure' terms for large scale models. Prediction of reactor runaway is still not feasible.
- The wide GAP between academic research and industrial practice is widening. It is aggravated by the diminishing expertise in the multiscale approach.

Consequences of Liquid Maldistribution: Simulated Hot Spot for Low Flow Region (3.3 inch Diameter Low Flow Region)

- In presence of hot spot catalyst dry-out may occur leading to rates 100-500 times higher due to reduced diffusional resistance – *this feeds the hot spot*

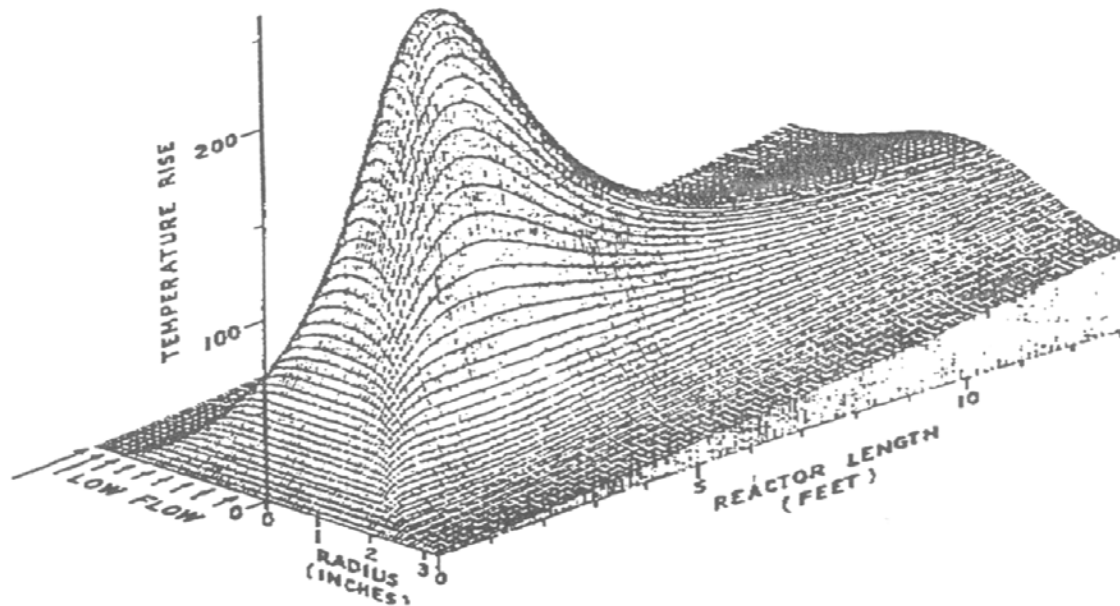

**Mobil; Jaffe,
I&EC, 1974**

Reaction Engineering of Heterogeneous Catalytic Systems... *Art*



Past & Present...

Science
Based
Multi-scale
Engineering

Science



... Future

Reference:

Three-Phase Trickle-Bed Reactors

MILORAD P. DUDUKOVIC, Chemical Reaction Engineering Laboratory (CREL),
Environmental, Energy and Chemical Engineering (EECE) Washington University,
St. Louis, Missouri 63130, United States

ZELJKO V. KUZELJEVIC, SABIC Innovative Plastics, Mt. Vernon, Indiana 47620,
United States

DANIEL P. COMBEST, Engys LLC, Indianapolis, Indiana 46268, United States

ULLMANN'S ENCYCLOPEDIA OF INDUSTRIAL CHEMISTRY

Test Case

Test Reaction

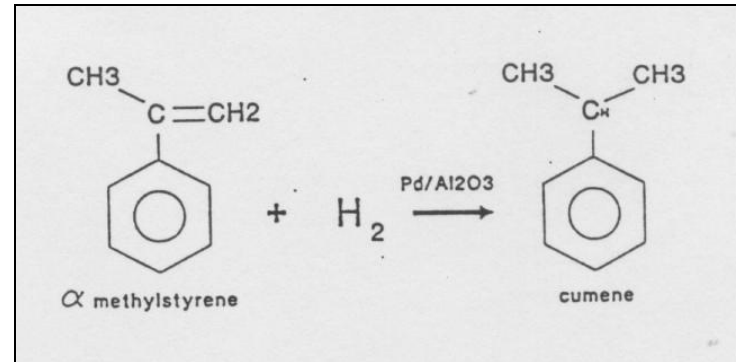

Catalyst: 0.05%, 0.5%, 2.5%, 5% Pd on Al₂O₃

Solvents: Hexane, Cyclohexane, Toluene, Isopropanol

Approach:

- Kinetic experiments
 - True kinetics (slurry)
 - Apparent kinetics (basket) and effectiveness factor determination
- Tracer experiments in Trickle Beds
 - Internal wetting
 - External wetting
- Trickle bed reactor models
 - Conversion prediction
- Comparison
 - Model and data (down-flow)
 - Of three modes of operation

Intrinsic Kinetic Rate

- To investigate intrinsic kinetics, experiments are performed in a slurry reactor using crashed catalyst and the whole system is well mixed

Intrinsic kinetics represent the reaction rates without the following limitations:

External mass transfer

- Increase stirring rate of the reactor contents

Internal diffusion

- Use crashed catalyst (decrease catalyst size)

Catalyst deactivation!

- Use fresh catalyst
- Regenerate catalyst

Apparent Kinetic Rate

- To investigate apparent kinetics, experiments are performed in a basket mixed reactor using regular fully wetted catalyst.

Apparent Kinetics represents the reaction rate without the following limitations:

External diffusion

- Increase stirring rate of the reactor contents

Catalyst deactivation

- Use fresh catalyst
- Regenerate catalyst

Intrinsic, Apparent Kinetics and Effectiveness Factor

$$(\text{Apparent Rate}) = (\text{Effectiveness factor}) \times (\text{Intrinsic Rate})$$



- **Provides estimate of internal diffusion effects**
- **Depends on:**
 - **catalyst geometry**
 - **effective diffusivity of reactants**
 - **reaction rate**

Experimental Setups for Kinetics Investigation

Basket mixed reactor

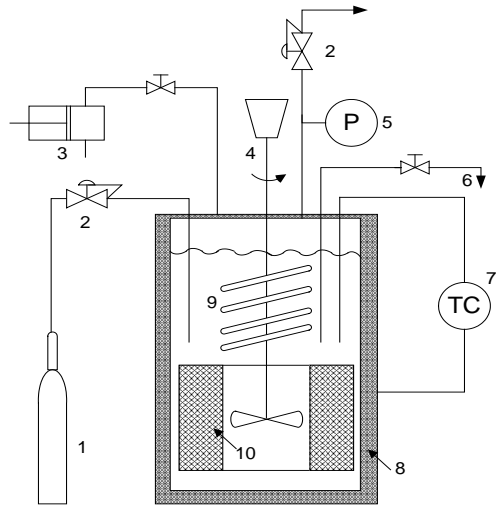

Slurry mixed reactor

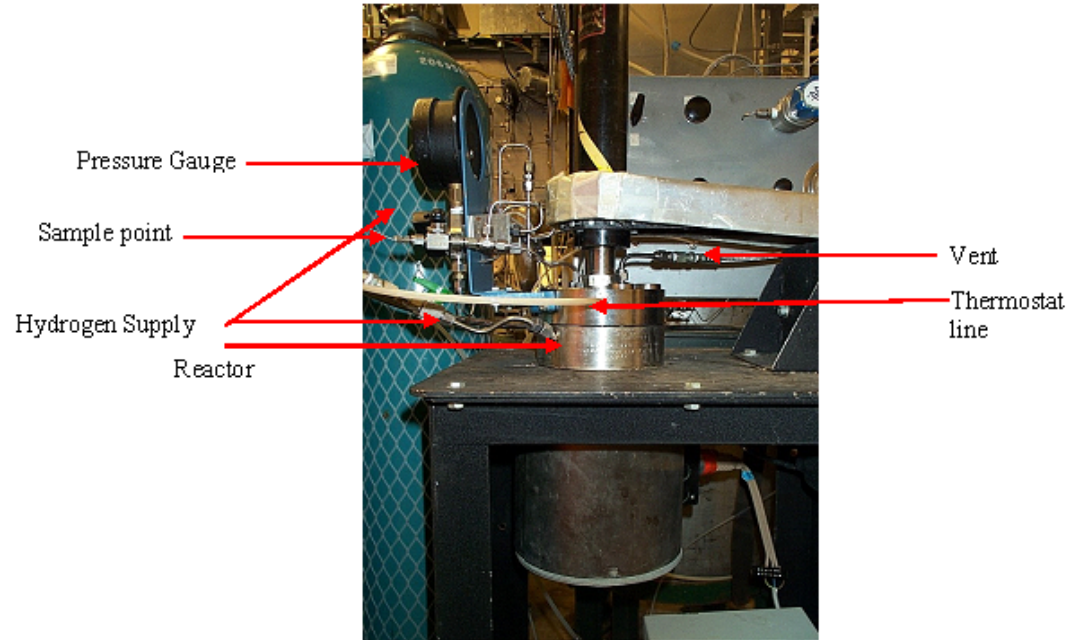
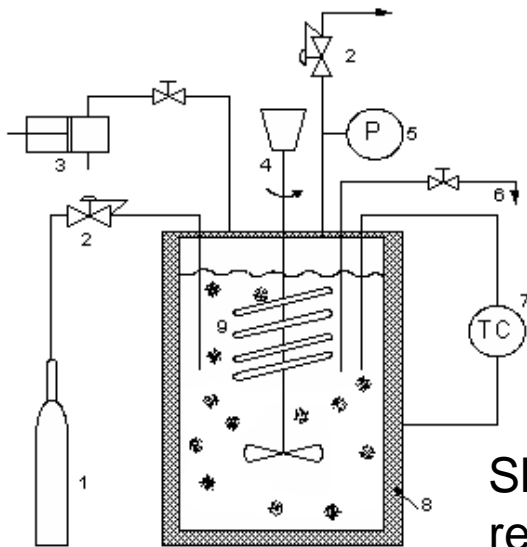

Autoclave slurry/basket reactor

Effect of operating conditions

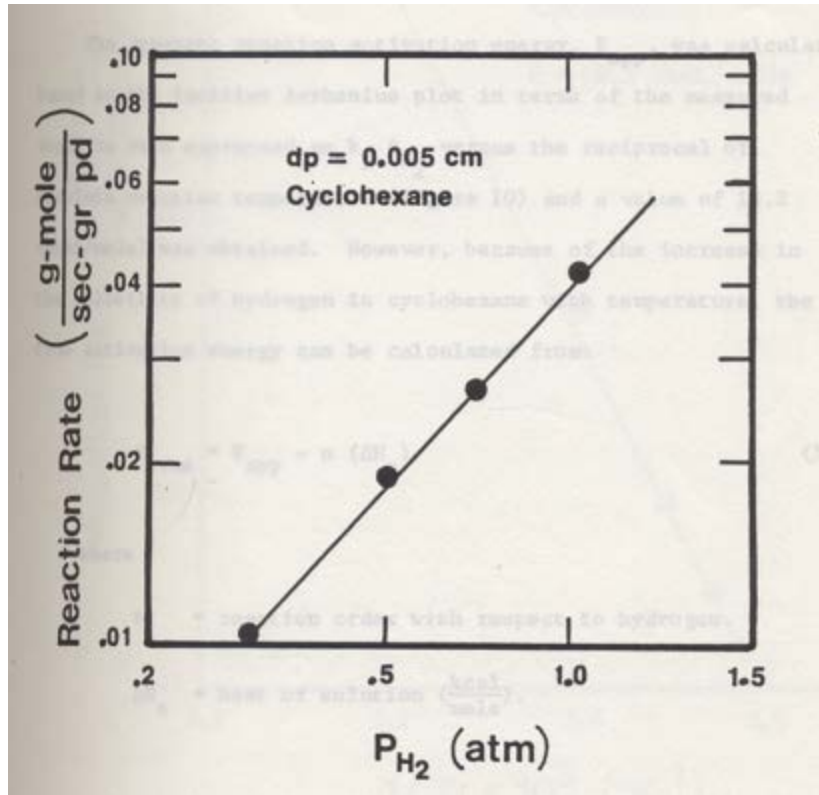

Reaction rate is first order in hydrogen

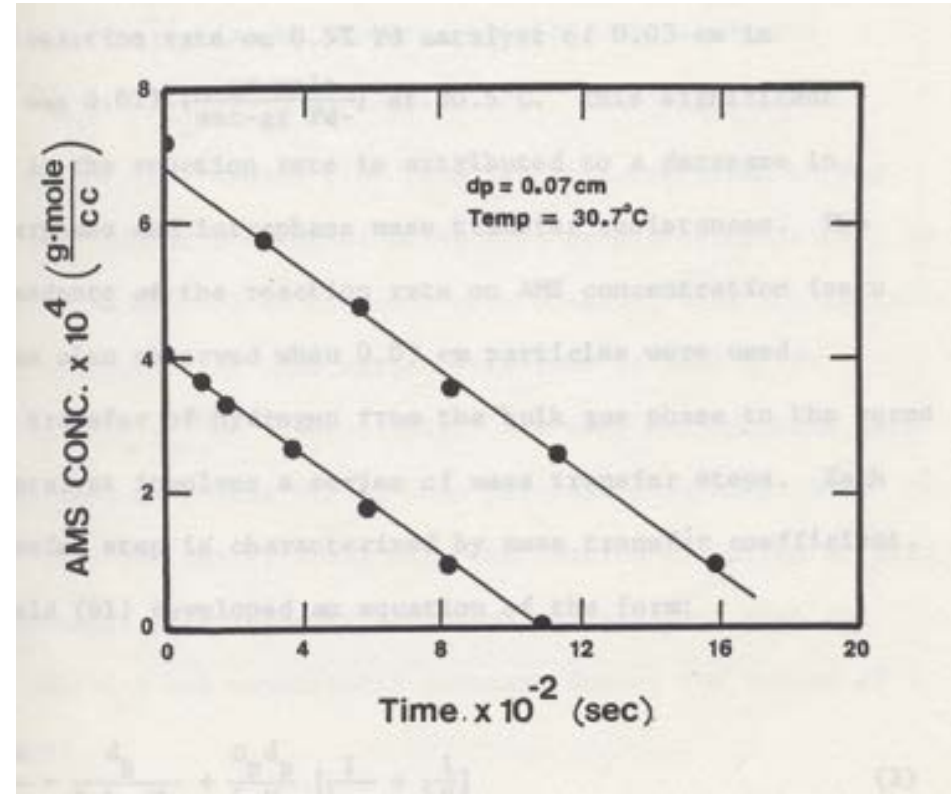

Reaction rate is zeroth order in alpha-methylstyrene

All experiments performed in internal and external diffusion limitations free regime (crashed particles, intense mixing); this is intrinsic rate

Effect of temperature

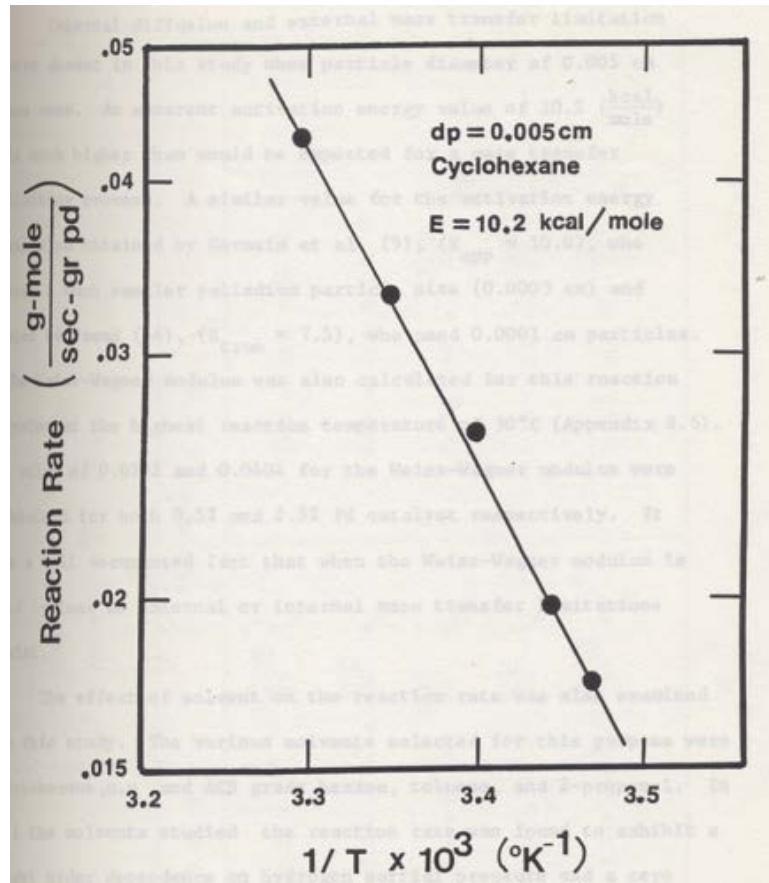

Based on measured reaction rate (in absence of internal and external diffusion limitations) at different temperatures, activation energy has been found

Apparent Kinetics - Experimental Results

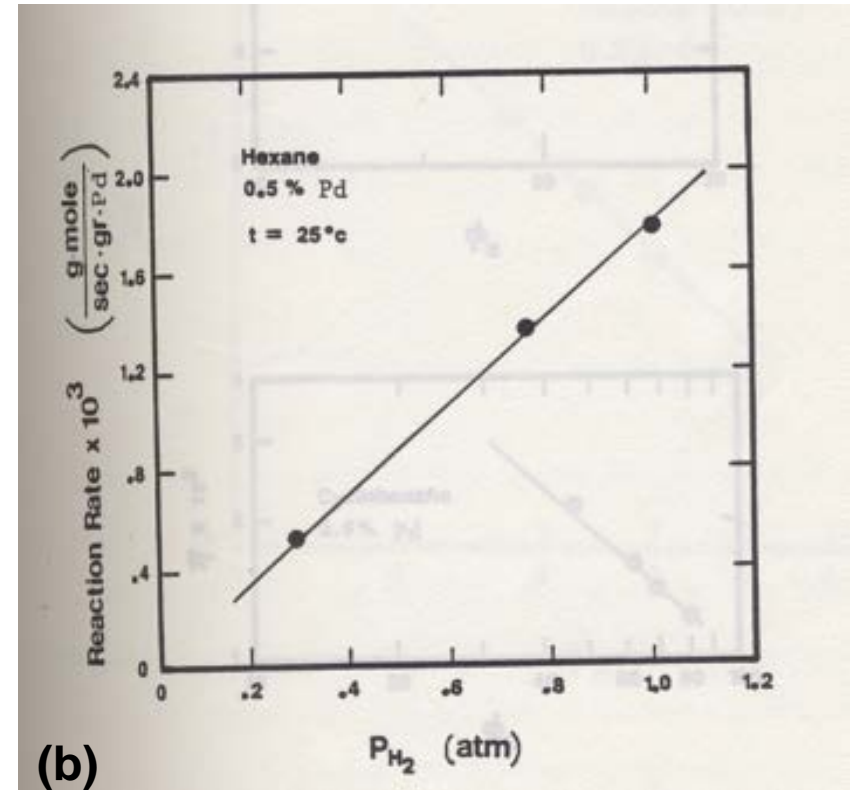
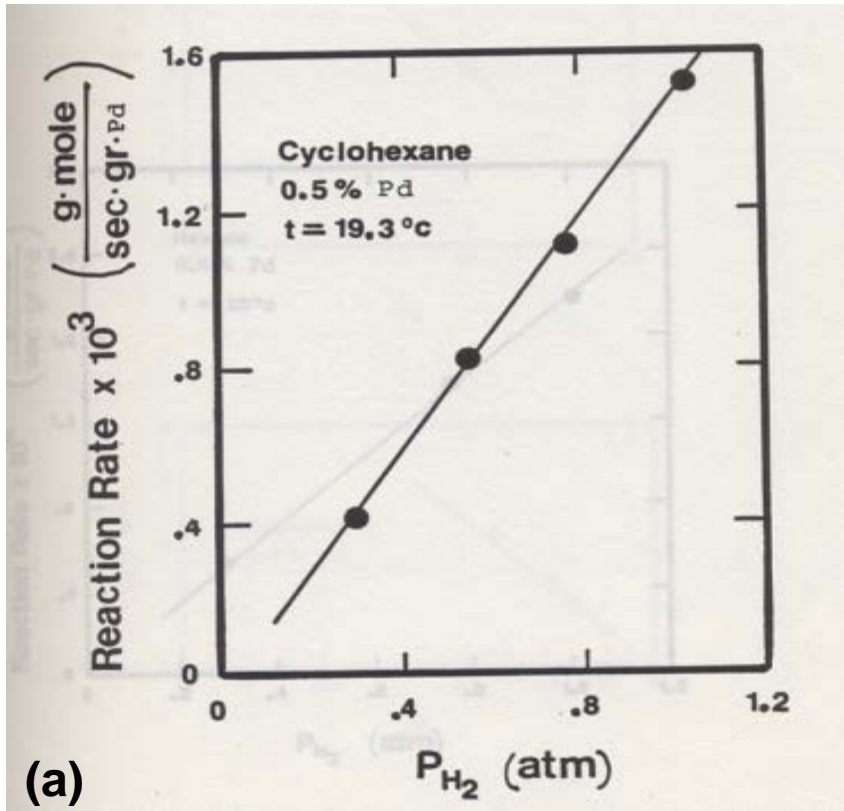

Apparent reaction rate as a function of hydrogen partial pressure shows first order dependence

Catalyst: 0.5% Pd on 0.13 cm x 0.56 cm alumina pellets

Solvent: (a) Cyclohexane (b) Hexane

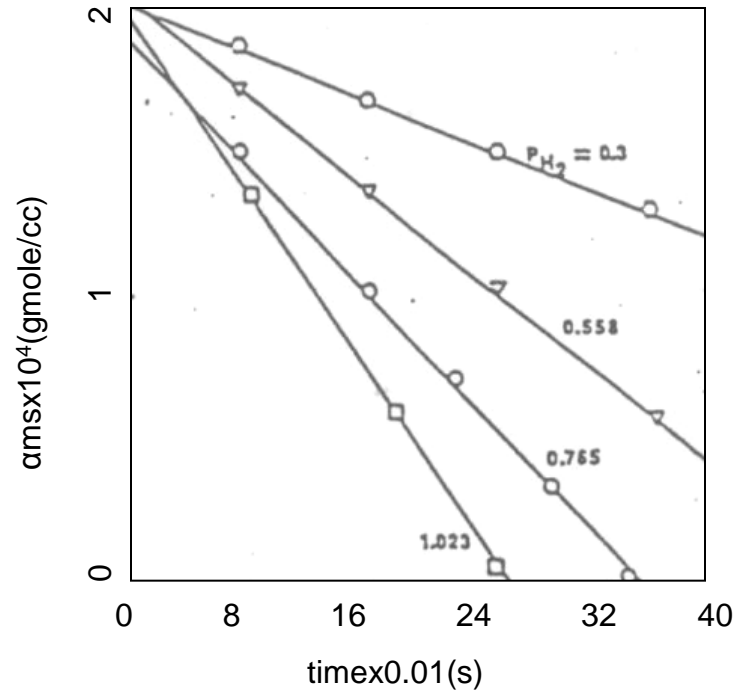
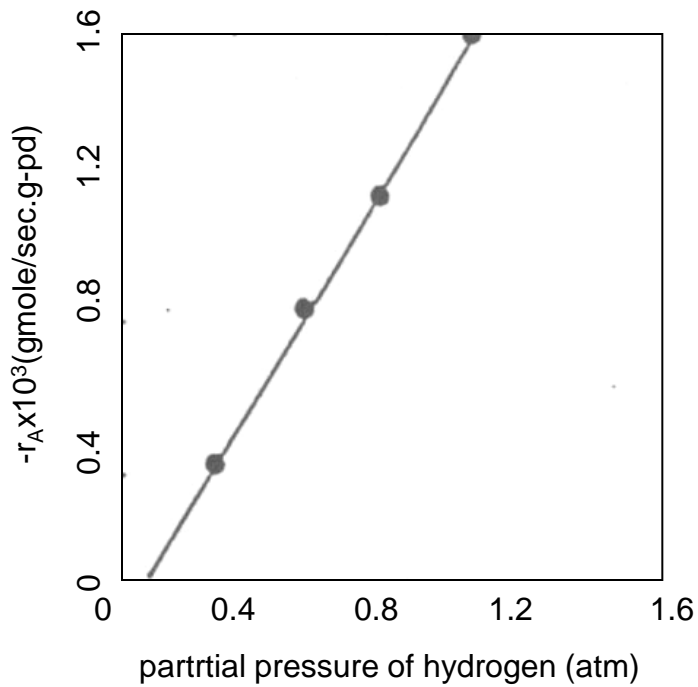

Reaction rate found to be:

- First order in hydrogen
- Zeroth order in alpha-methylstyrene (AMS)

Effectiveness factor of completely wetted pellets

- In basket (2.5% Pd on Al_2O_3 at $15^\circ C < T < 30^\circ C$)

$$0.05 < \eta_p < 0.08 \text{ (cyclohexane)}$$

$$0.17 < \eta_p < 0.21 \text{ (hexane)}$$

- In trickle bed (partial wetting)

$$\eta_{TB} = f(\eta_p, \eta_{CE}, \eta_C, Bi_d, Bi_w)$$

Experimental Data and Model Predictions Using Literature Correlations for Downflow Mass Transfer

$$\left(\eta k_v; \eta_{CE} = 1; k_{ls}; (ka)_{gl} \right); \left(\eta_{CE} < 1; \frac{1}{k_{iws}a} = 0 \right)$$

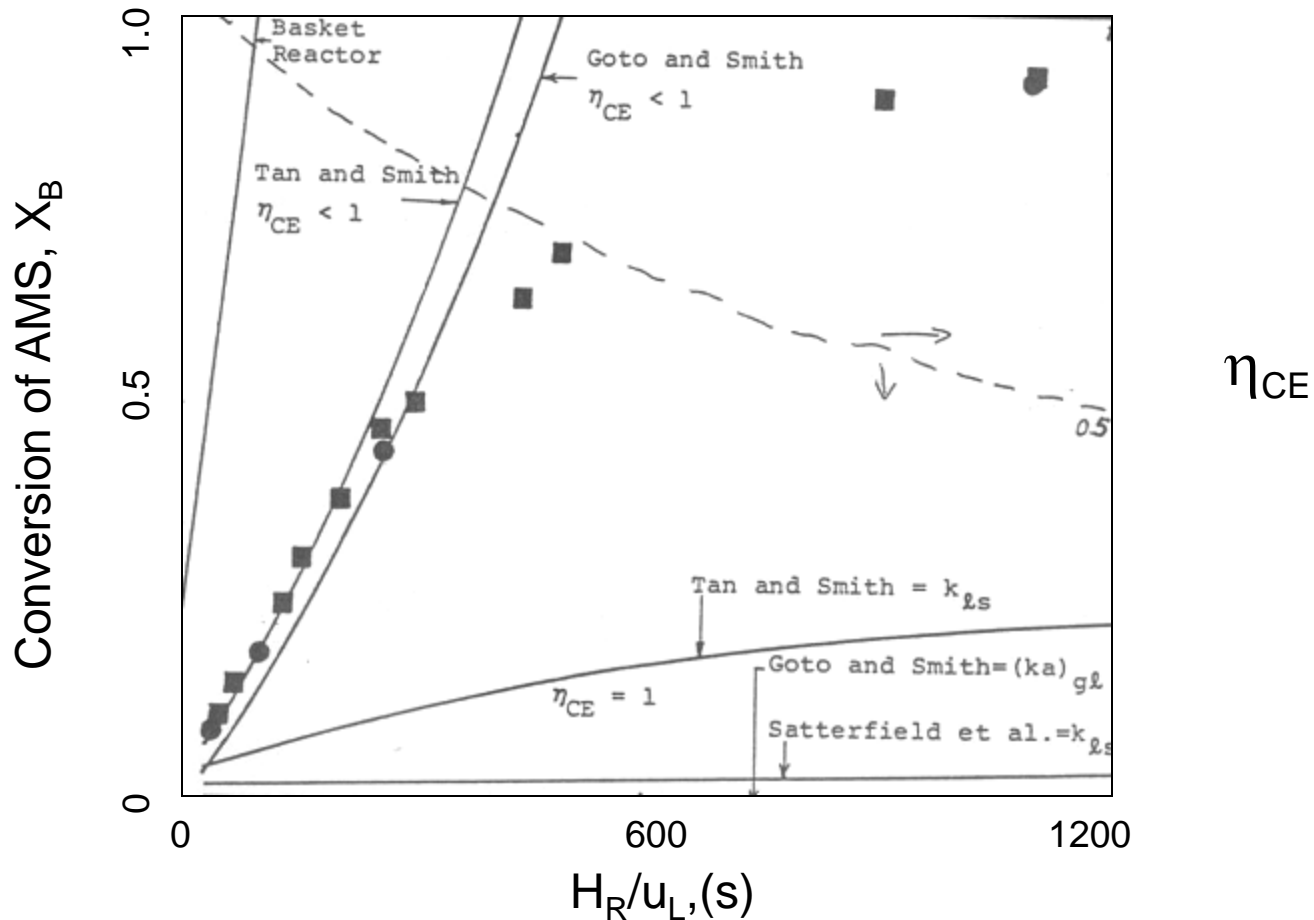

Reactor Scale Model

Dry Half-wet Fully-wet
 Flowing liquid Catalyst pellet

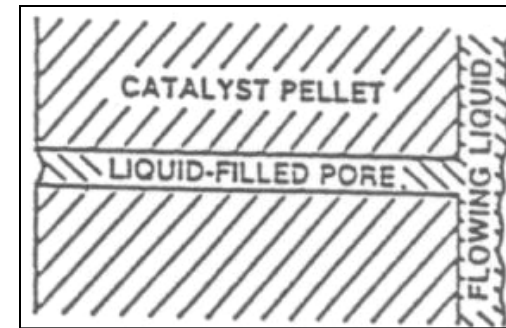
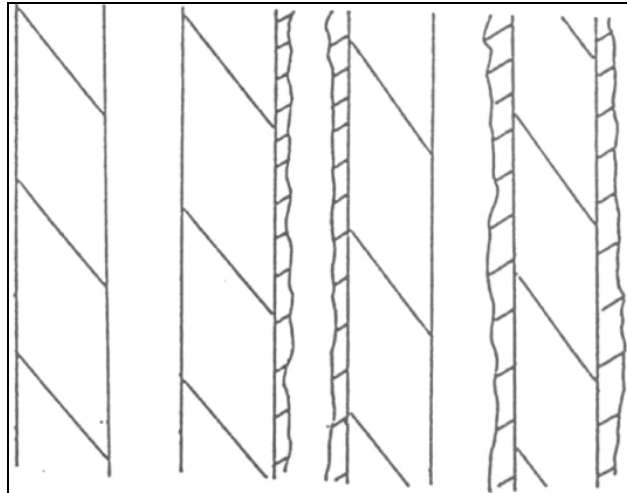

Half-wetted pellet

Volume fraction in each group

$$(1 - \eta_{CE})^2 + 2(1 - \eta_{CE})\eta_{CE} + \eta_{CE}^2 = 1.0$$

Depletion of liquid reactant happens in partially wetted pellet even when it cannot occur in completely wetted one i.e. $De_B C_{Bi} / De_A C_{Ai} >> 1$

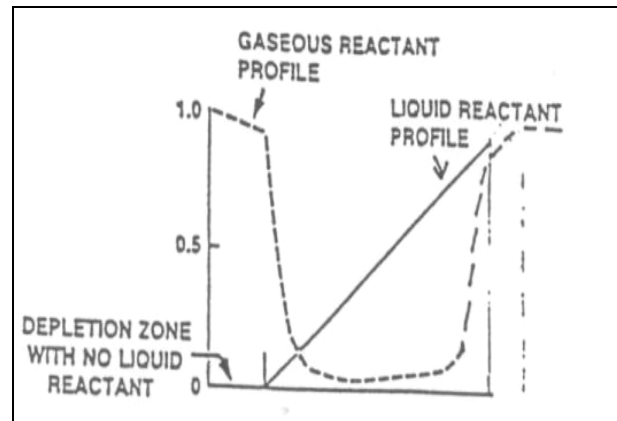

Can happen whenever

$$X_B > 1 - \frac{3\Lambda_p v De_A A^*}{De_B C_{Bio}}$$

$$X_B = \frac{bP_A L_R}{H_A C_{Blo} U_L} \left(\frac{\eta_{CE}}{\frac{1}{k_{aws} a} + \frac{1}{\eta k_v (1-\varepsilon)}} + \frac{(1-\eta_{CE})}{\frac{1}{k_{iws} a} + \frac{1}{\eta k_v (1-\varepsilon)}} \right)$$

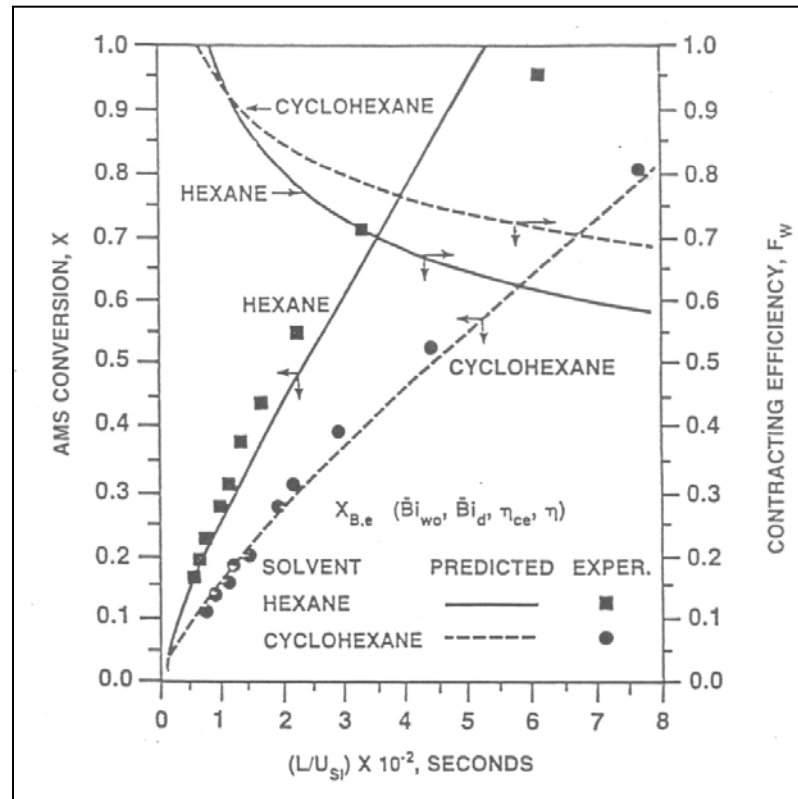

Experimental and model-predicted conversion for α -methylstyrene (AMS) hydrogenation in a laboratory-scale trickle bed reactor. (After Mills and Dudukovic, 1983)

0.5% Pd on alumina hexane solvent

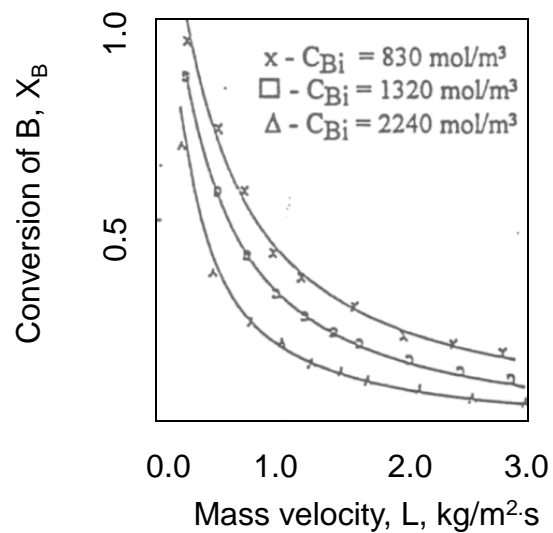

0.5% Pd on alumina cyclohexane solvent

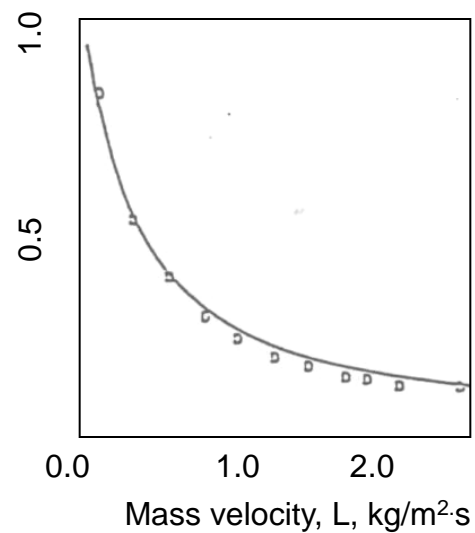

2.5% Pd on alumina cyclohexane solvent

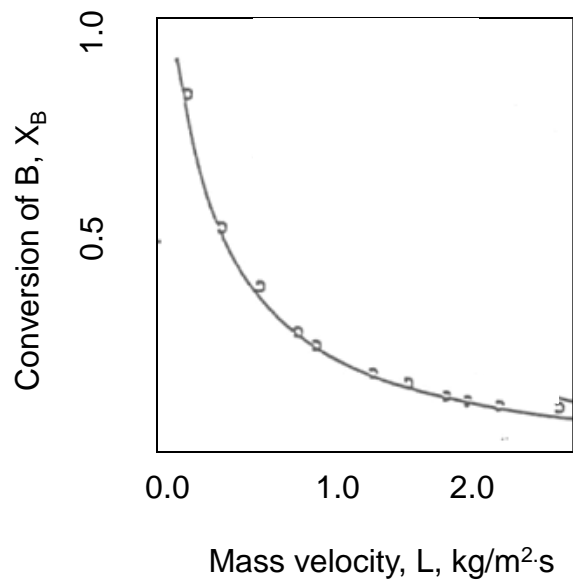

Maleic acid hydrogenation

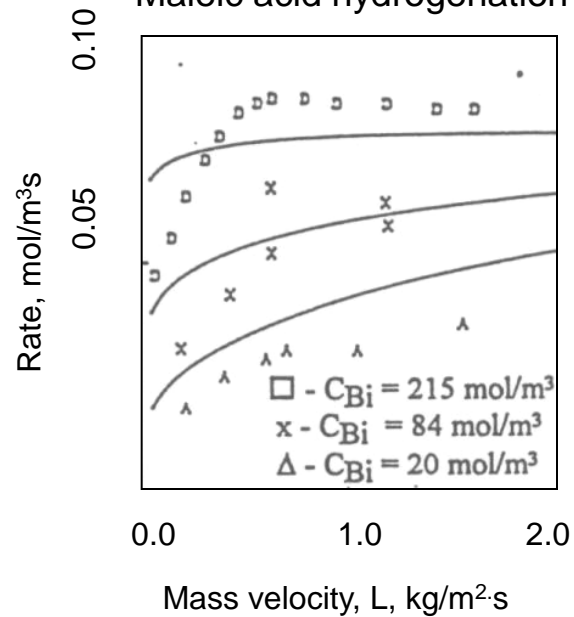

Prediction of TBR performance for gas-limited reactions demonstrated

Given:

- Slurry kinetic data
- Effectiveness factor on particles to be used (basket reactor)
- Correlation for wetting efficiency
- Correlations for gas-liquid-solid mass transfer
- Reactor model that accounts for partially wetted particles

Model predictability demonstrated by

- Changing catalyst activity (0.05%Pd, 2.5%Pd, 5%Pd all on alumina)
- Changing solvent (hexane, cyclohexane, etc.)
- Changing reaction system (e.g. hydrogenation of α -methyl styrene and of maleic acid)

Models based on first principles have the predictive ability for determination of reactor performance

Importance of partial wetting in trickle beds illustrated.

TRICKLE BED REACTOR

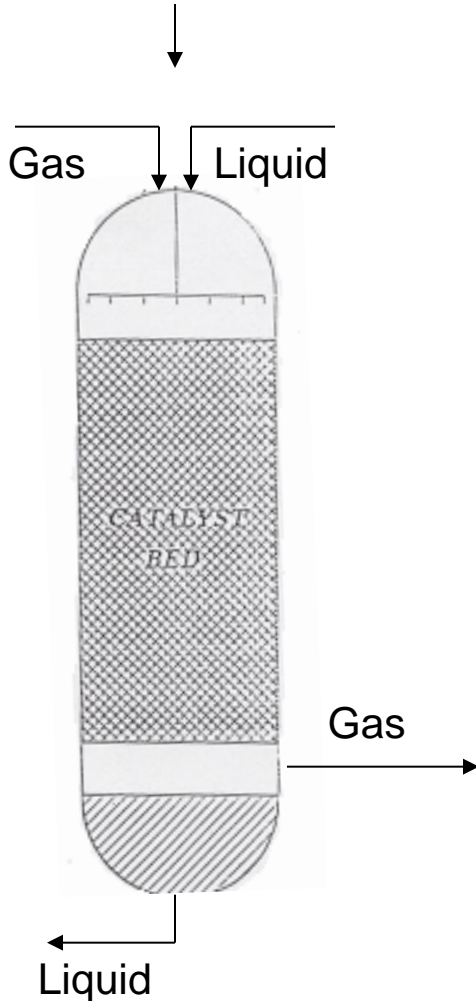

Partial wetting

PACKED BUBBLE COLUMN

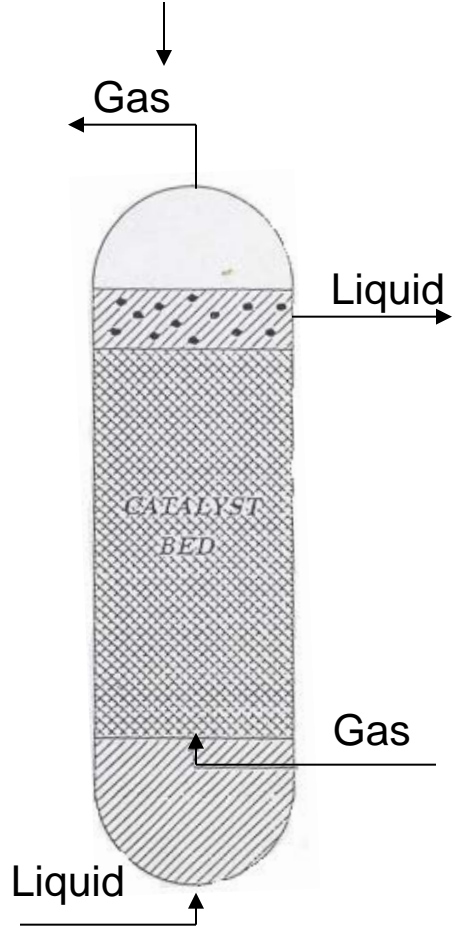

Complete wetting

FLOW REGIMES AND CATALYST WETTING EFFECTS

DOWNFLOW (TRICKLE BED REACTOR)

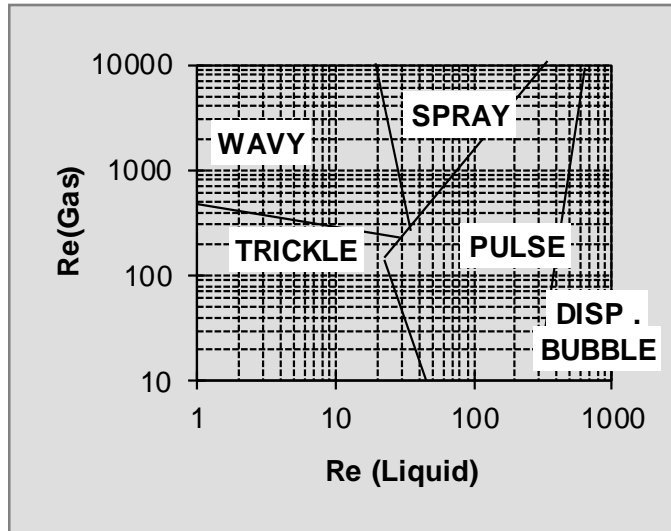

UPFLOW (PACKED BUBBLE COLUMN)

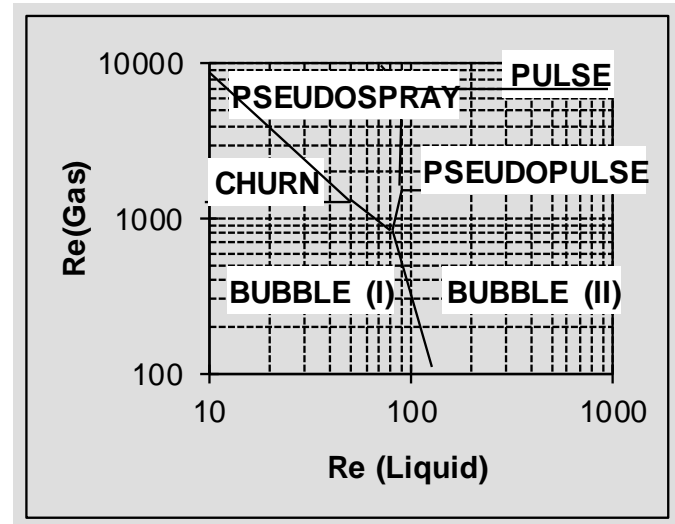

PARTIAL WETTING

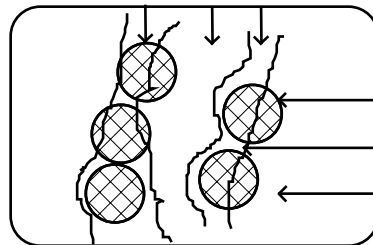

(Trickle Flow Regime)

COMPLETE WETTING

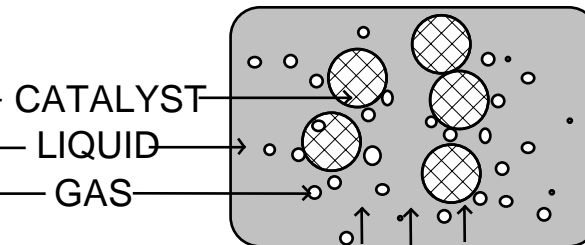

(Bubble Flow Regime)

Downflow and Upflow Experimental Results under Gas and Liquid Limited Conditions without Fines

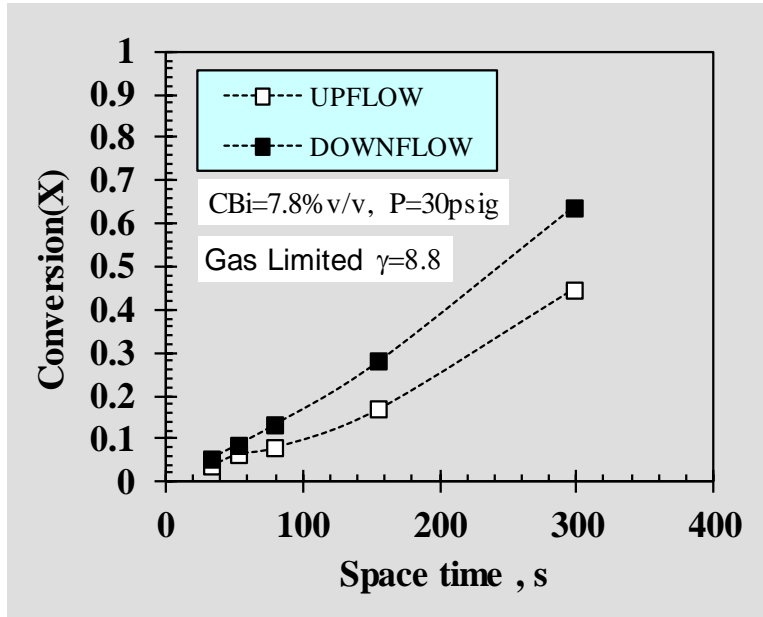

Downflow outperforms upflow due to partial external wetting and improved gas reactant access to particles

$$\gamma = D_{eL} C_B / D_{eG} C_A$$

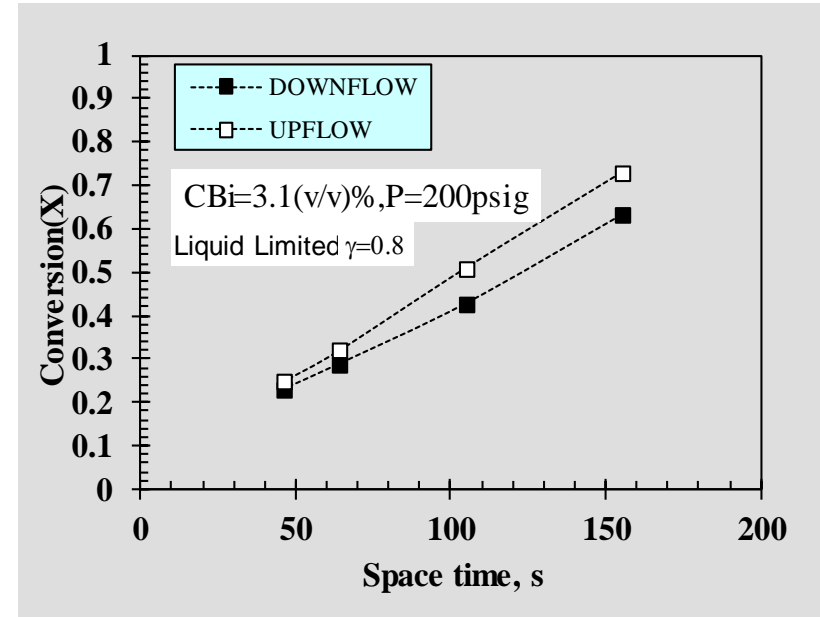

Upflow outperforms downflow due to more complete external wetting and better transport of liquid reactant to the catalyst

Downflow and Upflow Experimental Results under Gas and Liquid Limited Conditions with Fines

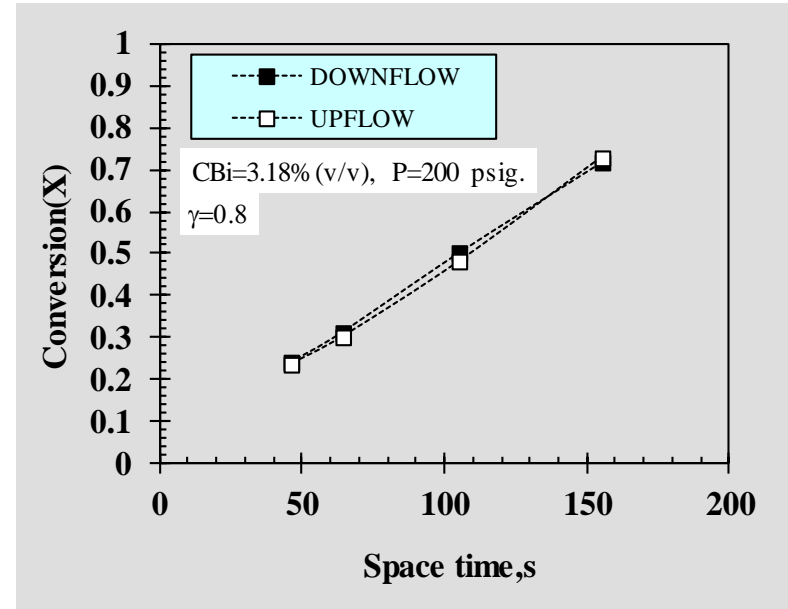
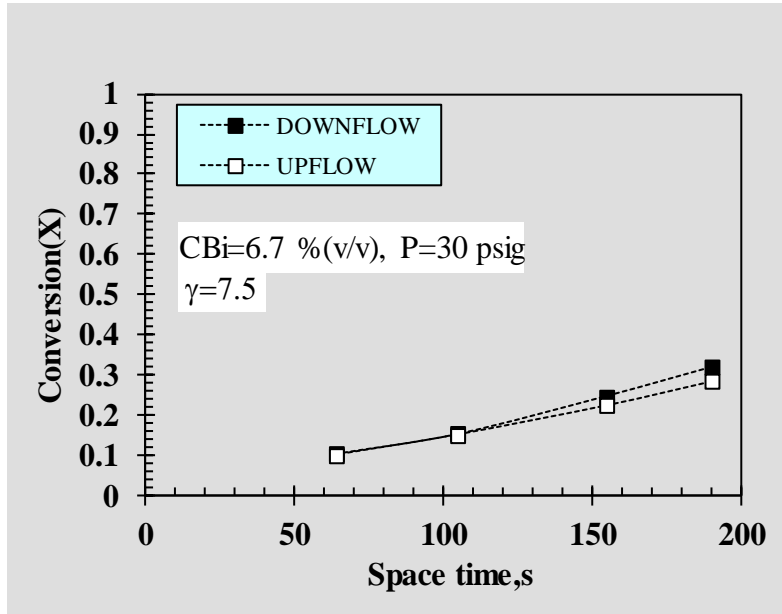

Fines Packing Procedure: Vol. of Fines ~Void volume (Al-Dahhan et al. 1995)

Conclusions:

- Knowledge of flow regime, limiting reactant and degree of liquid volatilization is important in scale-up
- Constant LHSV is conservative scale-up strategy for liquid limited reactions
- For gas limited reactions only constancy of both LHSV and reactor length guarantee conservative scale-up
- Adsorbing and non adsorbing tracers can provide information on:
 - particle scale incomplete contacting
 - liquid mal-distribution
- Use of fines separates kinetics from hydrodynamics and reduces the differences between up-flow and down-flow
- Model based prediction of performance of trickle beds is possible and highly advisable